

## Indexing Plungers 717, with Rest Position

**Material Standard Version:** Body zinc-plated, blue passivated.  
**Material Stainless Version:** Body stainless steel 1.4305 (AISI 303).  
 Both versions: Plunger pin stainless steel 1.4305 (AISI 303).  
 Spring stainless steel 1.4310. Knob (type B/BK) plastic (Polyamide PA) black, matt finish, not removable.



Indexing plungers 717 are reasonably priced, with small dimensions, for applications where high precision indexing is not required.

Indexing Plungers with rest position are used where the pin has to remain in retracted position. To achieve this, the knob is rotated by 90 degrees after being retracted. A notched catch stops the locked-in knob from returning to its initial position accidentally or due to vibration.

**Type C:** with rest position, with knob, without counter nut.

**Type CK:** with rest position, with knob ring, with counter nut.

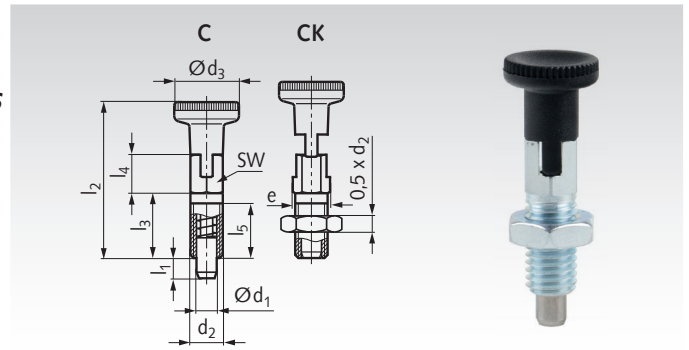

**Type C:** with rest position, with knob, without counter nut.  
**Type CK:** with rest position, with knob, with counter nut.

Ordering Details: e.g.: Product No. 666 717 53, Indexing Plunger 717 type C, 3mm

Product No. Standard	Product No. Stainless	Type	d <sub>1</sub> mm	l <sub>1</sub> min. mm	d <sub>2</sub> mm	d <sub>3</sub> mm	e mm	l <sub>2</sub> max. mm	l <sub>3</sub> mm	l <sub>4</sub> mm	l <sub>5</sub> mm	sw mm	T <sub>A</sub> ** Nm	Spring Load* Initial N	Spring Load* End N	Weight g
666 717 53	666 718 53	C	3	3,5	M6	12	6,9	29	12	7	10	6	2	3	12	4
666 717 54	666 718 54	C	3	3,5	M6 x 0,75	12	6,9	29	12	7	10	6	3	3	12	4
666 717 55	666 718 55	C	4	4	M6	12	6,9	29	12	7	10	6	2	3	12	4
666 717 56	666 718 56	C	4	4,5	M8 x 1	16	9,2	38,5	16	9,5	13,5	8	8	5	24	10
666 717 57	666 718 57	C	5	5	M8	16	9,2	38,5	16	9,5	13,5	8	7	5	24	10
666 717 58	666 718 58	C	5	5	M8 x 1	16	9,2	38,5	16	9,5	13,5	8	7	5	24	10
666 717 59	666 718 59	C	5	5	M10 x 1	18	11,5	41	16	10	13,5	10	22	5	24	16
666 717 60	666 718 60	C	6	6	M10	18	11,5	46	20	10,5	17	10	15	5	21	19
666 717 61	666 718 61	C	6	6	M12 x 1,5	21	13,8	49	20	11	16,5	12	38	5	21	27
666 717 62	666 718 62	C	8	8	M12	21	13,8	55,5	24	13,5	20,5	12	20	6	22	34
666 717 63	666 718 63	C	8	8	M12 x 1,5	21	13,8	55,5	24	13,5	20,5	12	20	6	22	57
666 717 64	666 718 64	C	8	8	M16 x 1,5	25	19,6	60	24	13,5	20,5	17	80	6	22	60
666 717 65	666 718 65	C	10	10	M16 x 1,5	25	19,6	62,5	26	14	22,5	17	80	4	27	66
666 717 66	666 718 66	CK	3	3,5	M6	12	6,9	29	12	7	10	6	2	3	12	17
666 717 68	666 718 68	CK	4	4	M6	12	6,9	29	12	7	10	6	2	3	12	5
666 717 69	666 718 69	CK	4	4,5	M8 x 1	16	9,2	38,5	16	9,5	13,5	8	8	5	24	20
666 717 70	666 718 70	CK	5	5	M8	16	9,2	38,5	16	9,5	13,5	8	7	5	24	13
666 717 72	666 718 72	CK	5	5	M10 x 1	18	11,5	41	16	10	13,5	10	22	5	24	20
666 717 73	666 718 73	CK	6	6	M10	18	11,5	46	20	10,5	17	10	15	5	21	24
666 717 74	666 718 74	CK	6	6	M12 x 1,5	21	13,8	49	20	11	16,5	12	38	5	21	20
666 717 75	666 718 75	CK	8	8	M12	21	13,8	55,5	24	13,5	20,5	12	20	6	22	44
666 717 76	666 718 76	CK	8	8	M12 x 1,5	21	13,8	55,5	24	13,5	20,5	12	20	6	22	57
666 717 77	666 718 77	CK	8	8	M16 x 1,5	25	19,6	60	24	13,5	20,5	17	80	6	22	79
666 717 78	666 718 78	CK	10	10	M16 x 1,5	25	19,6	62,5	26	14	22,5	17	80	4	27	84

\* Statistical average.

\*\* Fastening torque during assembly.