

Clamping Bushes E and E-N

Material E: High-quality steel.

Material E-N: Stainless steel 1.405 (AISI 431).



The clamping bush consists of a double-walled steel sleeve filled with a pressure medium, and a flange part. Inside the flange there is a screw and a piston with seal to build up compression.

Function: When the thrust screw is tightened, the sleeve expands uniformly against shaft and hub, creating a rigid connection through frictional force. When the thrust screw is loosened, the bush returns to its initial position and can be easily disassembled.

Concentricity: 0.02 mm.

Tolerances: Shaft h7 for $d = 15$ mm.

Shaft k6-h7 for $d = 19, 22, 24, 28$ and 38 mm.

Shaft h8 for the other diameters d .

Hub H7.

Temperature range: -30 °C to 85 °C.

Ordering Details: e.g.: Product No. 615 915 00, Clamping Bush E, 15 mm

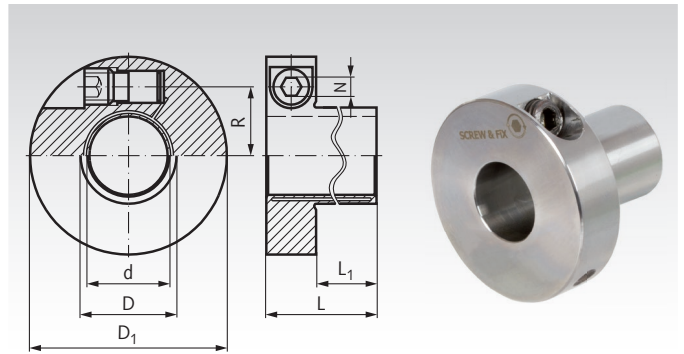

$P_W \approx 90\text{N/mm}^2$

$P_N \approx 70\text{N/mm}^2$

Product No. Design E Steel	Dimensions					at T_A transmittable			Screw 12.9*			Moment of Inertia J $\text{kgm}^2 \cdot 10^{-3}$	Weight kg	
	d mm	D mm	D_1 mm	L mm	L_1 mm	Torque T Nm	Axial Force F_{ax} kN	Radial Force F_r kN	Size DIN 915	R mm	N mm			T_A Nm
615 915 00	15	18	46	39	25	46	6,1	0,5	M10	15,1	5	5	0,043	0,16
615 915 87	15,88	19	47	40	26	53	6,7	0,5	M10	15,6	5	5	0,047	0,17
615 919 00	19	23	50,5	42	28	85	8,9	1	M10	17,4	5	5	0,064	0,20
615 919 05	19,05	23	50,5	42	28	85	8,9	1	M10	17,4	5	5	0,064	0,20
615 920 00	20	24	51,5	44	30	110	11	1	M10	18	5	5	0,070	0,21
615 922 00	22	27	55,5	46	32	130	11	1,2	M10	19,3	5	5	0,097	0,25
615 924 00	24	29	57,5	47	33	190	15	1,4	M10	20,3	5	5	0,112	0,27
615 925 00	25	30	58	49	35	230	18	1,5	M10	20,8	5	5	0,117	0,27
615 925 40	25,4	31	59	49	35	190	15	1,5	M10	21,2	5	5	0,127	0,29
615 928 00	28	34	63	52	38	280	20	1,8	M10	22,6	5	5	0,170	0,34
615 930 00	30	36	64,5	54	40	380	25	2	M10	23,6	5	5	0,189	0,35
615 931 75	31,75	39	68,5	56	42	430	27	2,2	M10	24,8	5	5	0,249	0,42
615 932 00	32	39	68,5	56	42	440	27	2,2	M10	24,8	5	5	0,249	0,42
615 935 00	35	42	73	59	45	640	36	2,5	M10	26,4	5	5	0,325	0,48
615 938 00	38	46	84,5	72	52	890	46	2,8	M16	31	8	21	0,761	0,84
615 940 00	40	48	86,5	75	55	1100	55	3	M16	32	8	21	0,844	0,88
615 945 00	45	54	93	78	58	1400	62	3,5	M16	34,8	8	21	1,170	1,05
615 948 00	48	59	97	79	59	1700	57	4	M16	36,8	8	21	1,460	1,21
615 950 00	50	60	98,5	80	60	1900	76	4,5	M16	37,5	8	21	1,524	1,20
615 960 00	60	73	115,5	90	70	3300	90	5,3	M16	43,3	8	21	3,171	1,85

Product No. Design E-N Stainless	Dimensions					at T_A transmittable			Screw A4*			Moment of Inertia J $\text{kgm}^2 \cdot 10^{-3}$	Weight kg	
	d mm	D mm	D_1 mm	L mm	L_1 mm	Torque T Nm	Axial Force F_{ax} kN	Radial Force F_r kN	Size DIN 915	R mm	N mm			T_A Nm
615 999 15	15	18	46	39	25	46	6,1	0,5	M10	15,1	5	5	0,043	0,16
615 999 20	20	24	51,5	44	30	110	11	1	M10	18	5	5	0,070	0,21
615 999 25	25	30	58	49	35	230	18	1,5	M10	20,8	5	5	0,117	0,27
615 999 30	30	36	64,5	54	40	380	25	2	M10	23,6	5	5	0,189	0,35
615 999 35	35	42	73	59	45	640	36	2,5	M10	26,4	5	5	0,325	0,48
615 999 40	40	48	86,5	75	55	1100	55	3	M16	32	8	21	0,844	0,88
615 999 45	45	54	93	78	58	1400	62	3,5	M16	34,8	8	21	1,170	1,05
615 999 50	50	60	98,5	80	60	1900	76	4,5	M16	37,5	8	21	1,524	1,20

T = transmittable torque at axial force of 0, if the screws are fastened with T_A .
 F_{ax} = transmittable axial force at torque of 0, if the screws are fastened with T_A .

F_r = maximum transmittable radial force.
 T_A = required fastening torque for the screws.
 * With coated thread.

Properties

The unique hydraulic principle leads to many advantages:

- very fast mounting/demounting with only **one thrust screw**.
- radial fastening of the thrust screw allows space saving installation conditions.
- very small assembly dimensions.
- good concentricity, even after several mountings.

Dimensioning

For the maximum torque, the shaft must be strong enough (min. strength 350 N/mm², for example C45).

The hub diameter must be big enough.

Recommend minimum hub diameter:

Hub from Steel: $ND = 1,4 \times D$.

Hub from grey cast iron: $ND = 2,0 \times D$.

Hub from Aluminium: $ND = 2,5 \times D$.

Mounting

Before mounting always check whether the threads are lubricated (OKS 260 or Molykote D).