

DO NOT SCALE DRAWING

REVISION

A	INITIAL DRAWING 5.12.17 DW
B	DIM "C" (LENGTH) POSITION CORRECTED TO SHOW FULL SCREW LENGTH. HEAT TREATMENT CORRECTED, WAS CASE HARDENED. 29/03/19 DW

PART NUMBER	A	B	C	D	E	RECESS
3.0 6 KRST30 Z100	3.0	1.66	6.0	2.05	5.5	POZI No 1
3.0 8 KRST30 Z100			8.0			
3.0 10 KRST30 Z100			10.0			
3.0 12 KRST30 Z100			12.0			
3.0 16 KRST30 Z100			16.0			
3.0 20 KRST30 Z100			20.0			
3.0 25 KRST30 Z100			25.0			
3.5 8 KRST30 Z100	3.5	1.91	8.0	2.8	7.3	POZI No 2
3.5 10 KRST30 Z100			10.0			
3.5 12 KRST30 Z100			12.0			
3.5 16 KRST30 Z100			16.0			
3.5 25 KRST30 Z100			25.0			
4.0 10 KRST30 Z100	4.0	2.17	10.0	2.5	8.0	POZI No 2
4.0 12 KRST30 Z100			12.0			
4.0 16 KRST30 Z100			16.0			
4.0 20 KRST30 Z100			20.0			
4.0 25 KRST30 Z100			25.0			
4.0 30 KRST30 Z100			30.0			
5.0 12 KRST30 Z100	5.0	2.68	12.0	3.4	9.3	POZI No 2
5.0 14 KRST30 Z100			14.0			
5.0 16 KRST30 Z100			16.0			
5.0 18 KRST30 Z100			18.0			
5.0 20 KRST30 Z100			20.0			
5.0 25 KRST30 Z100			25.0			
5.0 30 KRST30 Z100			30.0			

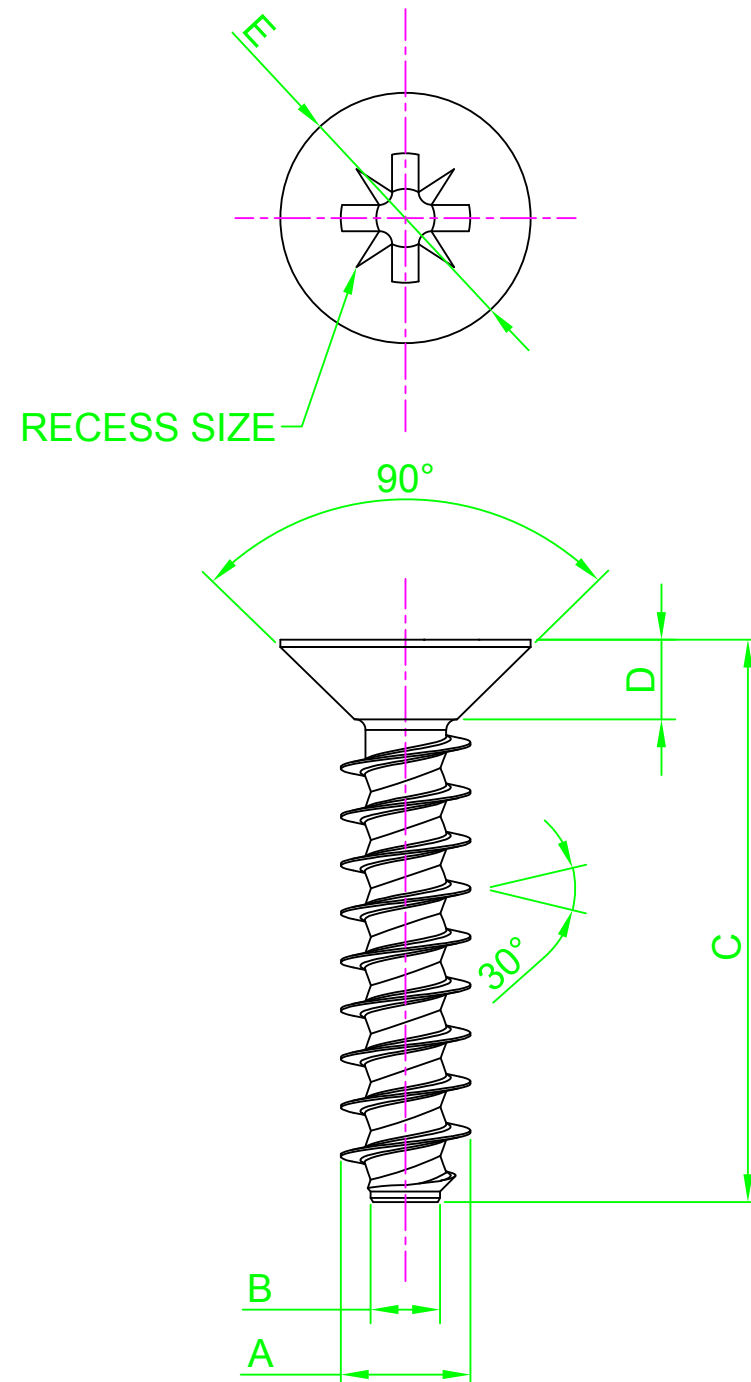

NOTES:



TR FASTENINGS LTD, 2003  
 UNDER NO CIRCUMSTANCES MUST THIS  
 DRAWING BE COPIED OR DISCLOSED  
 WITHOUT FIRST OBTAINING WRITTEN  
 AUTHORITY.

UNLESS OTHERWISE SPECIFIED:  
 DIMENSIONS ARE IN MM (MILLIMETERS).  
 SURFACE FINISH:  
 TOLERANCES:

	NAME	DATE
DRAWN	Darryl Wilson	05.12.2017
CHK'D		
APPVD		

MATERIAL:  
 STEEL

HEAT TREATMENT:  
 THROUGH HARDENED

FINISH:  
 TC1D - COMMERCIAL ZINC/CLEAR

TITLE:  
 POZI CSK HEAD POLYMATE 30  
 SCREW FOR PLASTIC

DRAWING NUMBER:  
 TR32KRST30

A4

PROJECTION

