

Part Number: 16/30HB

Type	Size	Rating	Description
Neon	T6	AC	High Brightness Wire-ended Neon Lamp

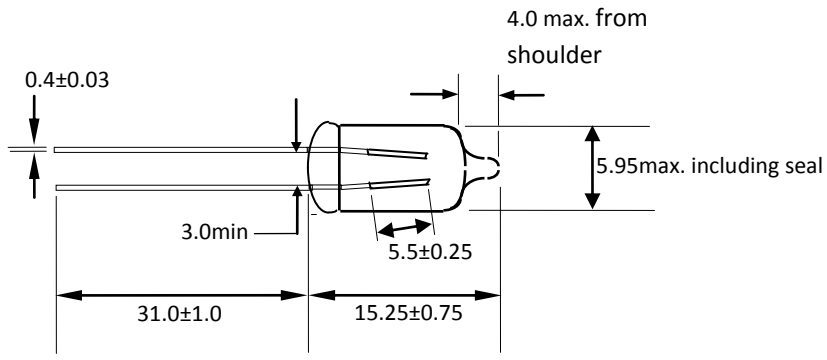

Dimensions in millimetres

Notes:

- |   |                              |                             |
|---|------------------------------|-----------------------------|
| 1 | <b>Brightness</b>            | High                        |
| 2 | <b>Lead Type</b>             | Tin plated                  |
| 3 | <b>Current</b>               | 1.8mA nominal               |
| 4 | <b>Strike Voltage</b>        | 95VAC maximum               |
| 5 | <b>Life</b>                  | 10,000 hrs. nominal         |
| 6 | <b>Operating temperature</b> | -50°C - +160°C              |
| 7 | <b>Environmental</b>         | RoHS & REACH SVHC compliant |