

Spezifikation für Freigabe / specification for release

Kunde / customer :
 Artikelnummer / part number : **7490100111A**
 Bezeichnung : **LAN-Übertrager WE-LAN**
 description : **LAN-Transformer WE-LAN**



DATUM / DATE : 2017-06-23

A Mechanische Abmessungen / dimensions :

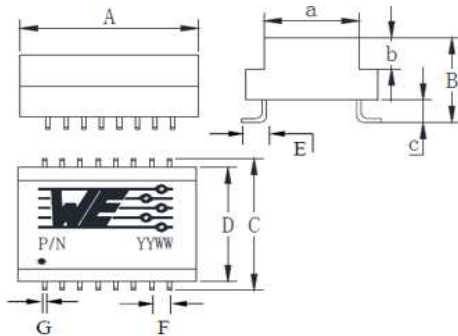

	10-100 BaseT	
A	12,7 ± 0,25	mm
B	6,35 max.	mm
C	9,40 ± 0,25	mm
D	8,80 ± 0,25	mm
E	1,20 ± 0,05	mm
F	1,27 ± 0,05	mm
G	0,30 ± 0,10	mm
a	6,80 ± 0,25	mm
b	2,40 ± 0,25	mm
c	1,55 max.	mm

● = Pin 1

B Elektrische Eigenschaften / electrical properties :

Eigenschaften / properties	Testbedingungen / test conditions		Wert / value	Einheit / unit	tol.
Induktivität / Inductance	100kHz / 100mV @ 8mA DC-Bias (16-14; 11-9)	OCL	350	µH	min.
Übersetzungsverhältnis / Turns ratio	100kHz / 100mV	TR	1 : 1 1 : 1	Tx Rx	3%
Insertion Loss	1-100MHz	IL	-1,1	dB	max.
Return Loss	1-30MHz @ 100Ω	RL	-18	dB	min.
	30-60MHz @ 100Ω		-14		
	60-80MHz @ 100Ω		-12		
	80-100MHz @ 100Ω		-10		
Differential to Common Mode Rejection	30MHz	DCMR	-38	dB	min.
	60MHz		-38		
	100MHz		-30		
Crosstalk	60MHz	CT	-40	dB	min.
	100MHz		-35		

C Lötpad / soldering spec. :

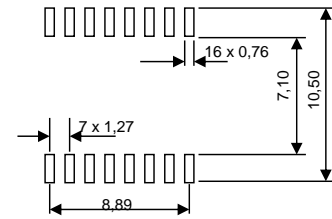

D Prüfgeräte / test equipment :

HP-4284 CH-19073
 HP-8714 CH-3250

E Testbedingungen / test conditions :

Luftfeuchtigkeit / humidity: 33%
 Umgebungstemperatur / temperature: +25°C

F Werkstoffe & Zulassungen / material & approvals :

Basismaterial / base material: Ferrit/ ferrite
 Draht / wire: 0UEW QPN200
 Kontaktmaterial/ contact plating: Cu-Ni-Sn
 Gehäuse/ case: Bakelite & UL94-V0

G Eigenschaften / general specifications :

Betriebstemp. / operating temperature: -40°C - + 105°C
 Hochspannungsprüfung / Hipot test: 1500Vrms 1min.
 Geeignet für 10/100Base-TX gemäß IEEE 802.3u /
 Coplanarität / Coplanarity: < 0,1 mm
 Compliant with IEEE 802.3u for 10/100Base-TX-Applications
 Auto MDIX fähig / Auto MDIX capable

Freigabe erteilt / general release:

Kunde / customer

Datum / date

Unterschrift / signature

Würth Elektronik

Geprüft / checked

Kontrolliert / approved

JaB	Version 06	2017-06-23
JaB	Version 05	2016-02-02
JaB	Version 04	2015-01-26
MLe	Version 03	2014-06-13
MLe	Version 02	2014-01-03
MLe	Version 01	2013-03-22
MLe	Version 00	2012-11-09
Name	Änderung / modification	Datum / date

Würth Elektronik eiSos GmbH & Co.KG

D-74638 Waldenburg · Max-Eyth-Straße 1 - 3 · Germany · Telefon (+49) (0) 7942 - 945 - 0 · Telefax (+49) (0) 7942 - 945 - 400
<http://www.we-online.com>

Spezifikation für Freigabe / specification for release

Kunde / customer :
 Artikelnummer / part number : **7490100111A**
 Bezeichnung : **LAN-Übertrager WE-LAN**
 description : **LAN-Transformer WE-LAN**



DATUM / DATE : 2017-06-23

H Schaltbild / Schematics :

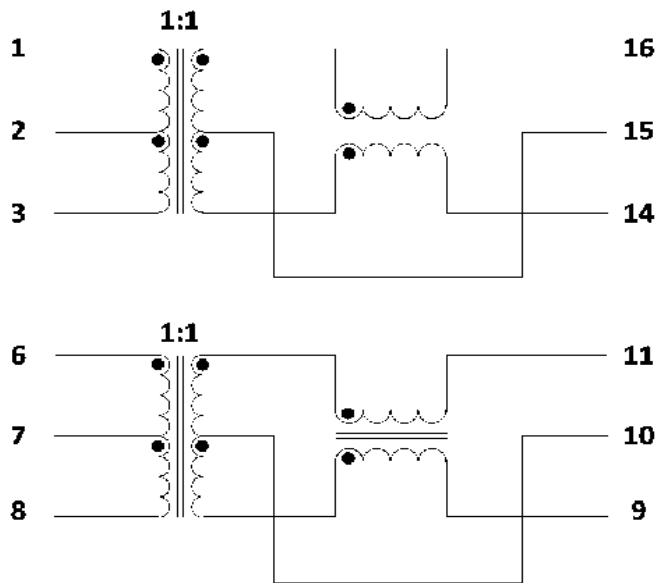

Freigabe erteilt / general release:	Kunde / customer			
		JaB	Version 06	2017-06-23
		JaB	Version 05	2016-02-02
		JaB	Version 04	2015-01-26
..... Datum / date Unterschrift / signature	MLe	Version 03	2014-06-13
	Würth Elektronik	MLe	Version 02	2014-01-03
		MLe	Version 01	2013-03-22
		MLe	Version 00	2012-11-09
..... Geprüft / checked Kontrolliert / approved	Name	Änderung / modification	Datum / date

Würth Elektronik eiSos GmbH & Co.KG

D-74638 Waldenburg · Max-Eyth-Straße 1 - 3 · Germany · Telefon (+49) (0) 7942 - 945 - 0 · Telefax (+49) (0) 7942 - 945 - 400
<http://www.we-online.com>

Spezifikation für Freigabe / specification for release

Kunde / customer :
 Artikelnummer / part number : **7490100111A**
 Bezeichnung : **LAN-Übertrager WE-LAN**
 description : **LAN-Transformer WE-LAN**



DATUM / DATE : 2017-06-23

I Rollenspezifikation / tape and reel specification :

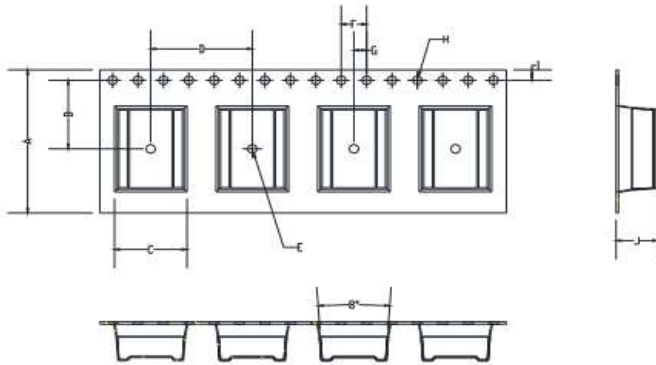

Gurtspezifikation / Tape specification:		
A	24,00 ± 0,1	mm
B	11,50 ± 0,1	mm
C	11,42 ± 0,1	mm
D	16,00 ± 0,1	mm
E	1,50 ± 0,1	mm
F	4,00 ± 0,1	mm
G	2,00 ± 0,1	mm
H	1,50 ± 0,1	mm
I	1,75 ± 0,1	mm
J	6,52 ± 0,1	mm

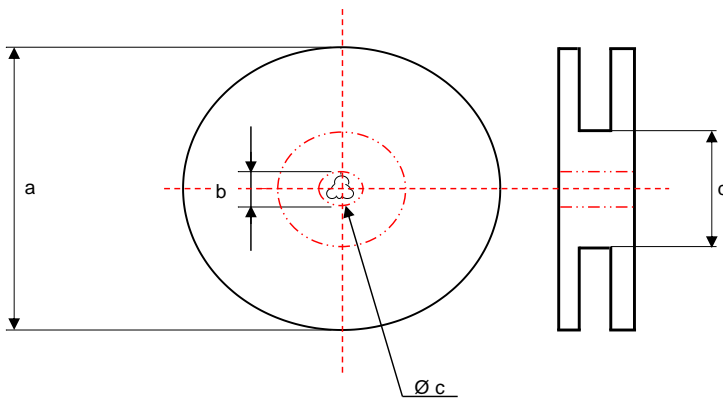

Rollenspezifikation / Reel specification:		
a	330,0 ± 2,0	mm
b	21,00 ± 0,8	mm
c	13,50 ± 0,5	mm
d	100,0 ± 1,0	mm

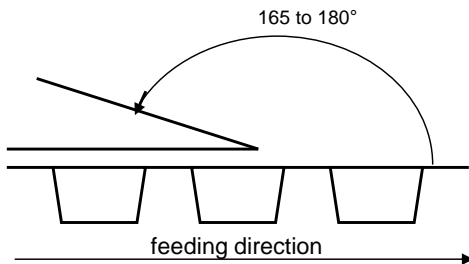

The force for tearing off cover tape is 40 to 120 grams in arrow direction

Freigabe erteilt / general release:	Kunde / customer		
	[Signature]		
Datum / date	Unterschrift / signature		
	Würth Elektronik		
Geprüft / checked	Kontrolliert / approved		
	[Signature]		
	JaB	Version 06	2017-06-23
	JaB	Version 05	2016-02-02
	JaB	Version 04	2015-01-26
	MLe	Version 03	2014-06-13
	MLe	Version 02	2014-01-03
	MLe	Version 01	2013-03-22
	MLe	Version 00	2012-11-09
	Name	Änderung / modification	Datum / date

This electronic component has been designed and developed for usage in general electronic equipment. Before incorporating this component into any equipment where higher safety and reliability is especially required or if there is the possibility of direct damage or injury to human body, for example in the range of aerospace, aviation, nuclear control, submarine, transportation, (automotive control, train control, ship control), transportation signal, disaster prevention, medical, public information network etc, Würth Elektronik eiSos GmbH must be informed before the design-in stage. In addition, sufficient reliability evaluation checks for safety must be performed on every electronic component which is used in electrical circuits that require high safety and reliability functions or performance.

Würth Elektronik eiSos GmbH & Co.KG

D-74638 Waldenburg · Max-Eyth-Straße 1 · 3 · Germany · Telefon (+49) (0) 7942 - 945 - 0 · Telefax (+49) (0) 7942 - 945 - 400
<http://www.we-online.com>

Spezifikation für Freigabe / specification for release

Kunde / customer :
 Artikelnummer / part number : **7490100111A**



Bezeichnung : **LAN-Übertrager WE-LAN**
 description : **LAN-Transformer WE-LAN**

DATUM / DATE : 2017-06-23

J Verpackung / Packaging :

Taping Orientation:

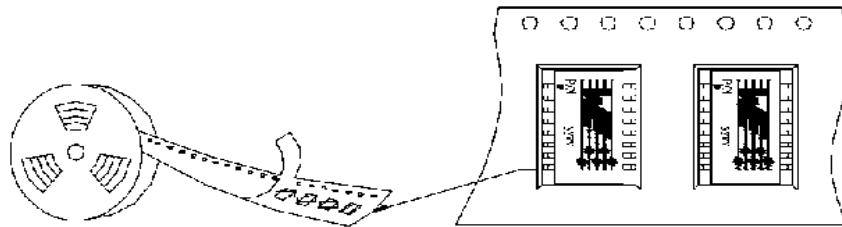

Package for Shipping:

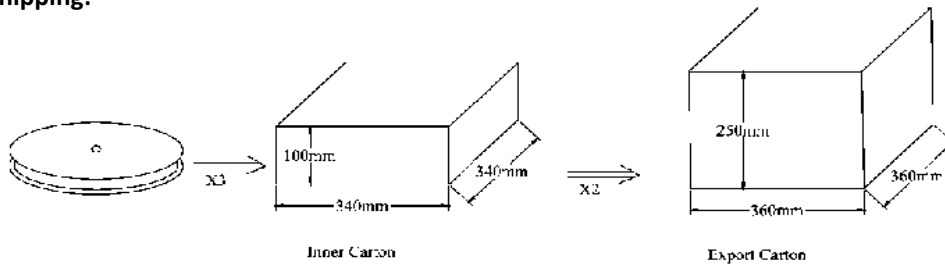

Quantity:
 600 PCS/Reel
 2 Reels/Inner Carton
 5 Inner Cartons/Export Carton
 6000 PCS/Big Carton

Freigabe erteilt / general release:	Kunde / customer		
Datum / date	Unterschrift / signature		
Geprüft / checked	Kontrolliert / approved		
Würth Elektronik			
		Name	Änderung / modification
			Datum / date
		JaB	Version 06
		JaB	Version 05
		JaB	Version 04
		MLe	Version 03
		MLe	Version 02
		MLe	Version 01
		MLe	Version 00

This electronic component has been designed and developed for usage in general electronic equipment. Before incorporating this component into any equipment where higher safety and reliability is especially required

Würth Elektronik eiSos GmbH & Co.KG

D-74638 Waldenburg · Max-Eyth-Straße 1 - 3 · Germany · Telefon (+49) (0) 7942 - 945 - 0 · Telefax (+49) (0) 7942 - 945 - 400
<http://www.we-online.com>