

# LM2586

*LM2586 SIMPLE SWITCHER 3A Flyback Regulator with Shutdown*



Literature Number: SNVS121C

# LM2586 SIMPLE SWITCHER® 3A Flyback Regulator with Shutdown

## General Description

The LM2586 series of regulators are monolithic integrated circuits specifically designed for flyback, step-up (boost), and forward converter applications. The device is available in 4 different output voltage versions: 3.3V, 5.0V, 12V, and adjustable.

Requiring a minimum number of external components, these regulators are cost effective, and simple to use. Included in the datasheet are typical circuits of boost and flyback regulators. Also listed are selector guides for diodes and capacitors and a family of standard inductors and flyback transformers designed to work with these switching regulators.

The power switch is a 3.0A NPN device that can stand-off 65V. Protecting the power switch are current and thermal limiting circuits, and an undervoltage lockout circuit. This IC contains an adjustable frequency oscillator that can be programmed up to 200 kHz. The oscillator can also be synchronized with other devices, so that multiple devices can operate at the same switching frequency.

Other features include soft start mode to reduce in-rush current during start up, and current mode control for improved rejection of input voltage and output load transients and cycle-by-cycle current limiting. The device also has a shutdown pin, so that it can be turned off externally. An output voltage tolerance of  $\pm 4\%$ , within specified input voltages and output load conditions, is guaranteed for the power supply system.

## Features

- Requires few external components
- Family of standard inductors and transformers
- NPN output switches 3.0A, can stand off 65V
- Wide input voltage range: 4V to 40V
- Adjustable switching frequency: 100 kHz to 200 kHz
- External shutdown capability
- Draws less than 60  $\mu\text{A}$  when shut down
- Frequency synchronization
- Current-mode operation for improved transient response, line regulation, and current limit
- Internal soft-start function reduces in-rush current during start-up
- Output transistor protected by current limit, under voltage lockout, and thermal shutdown
- System output voltage tolerance of  $\pm 4\%$  max over line and load conditions

## Typical Applications

- Flyback regulator
- Forward converter
- Multiple-output regulator
- Simple boost regulator

## Connection Diagrams

Bent, Staggered Leads  
7-Lead TO-220 (T)  
Top View

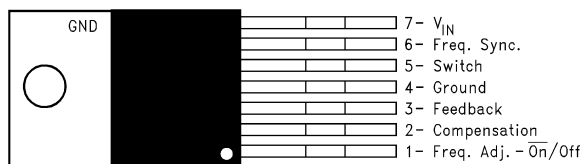

01251617

Bent, Staggered Leads  
7-Lead TO-220 (T)  
Side View

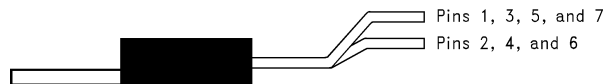

01251618

Order Number LM2586T3.3, LM2586T-5.0,  
LM2586T-12 or LM2586T-ADJ  
See NS Package Number TA07B

## Connection Diagrams (Continued)

7-Lead TO-263 (S)  
Top View

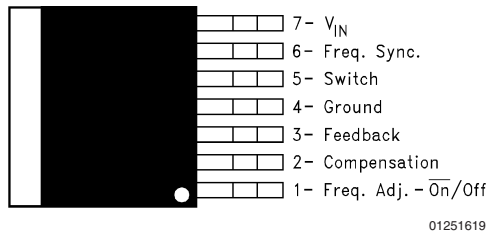

7-Lead TO-263 (S)  
Side View



Order number LM2586S-3.3, LM2586S-5.0,  
LM2586S-12 or LM2586S-ADJ  
Tape and Reel Order Number LM2586SX-3.3,  
LM2586SX-5.0, LM2586SX-12 or LM2586SX-ADJ  
See NS Package Number TS7B

## Ordering Information

Package Type	NSC Package Drawing	Order Number
7-Lead TO-220 Bent, Staggered Leads	TA07B	LM2586T-3.3, LM2586T-5.0, LM2586T-12, LM2586T-ADJ
7-Lead TO-263	TS7B	LM2586S-3.3, LM2586S-5.0, LM2586S-12, LM2586S-ADJ
7-Lead TO-263 Tape and Reel	TS7B	LM2586SX-3.3, LM2586SX-5.0, LM2586SX-12, LM2586SX-ADJ

**Absolute Maximum Ratings** (Note 1)

If Military/Aerospace specified devices are required, please contact the National Semiconductor Sales Office/Distributors for availability and specifications.

Input Voltage	$-0.4V \leq V_{IN} \leq 45V$
Switch Voltage	$-0.4V \leq V_{SW} \leq 65V$
Switch Current (Note 2)	Internally Limited
Compensation Pin Voltage	$-0.4V \leq V_{COMP} \leq 2.4V$
Feedback Pin Voltage	$-0.4V \leq V_{FB} \leq 2 V_{OUT}$
$\overline{ON}$ /OFF Pin Voltage	$-0.4V \leq V_{SH} \leq 6V$
Sync Pin Voltage	$-0.4V \leq V_{SYNC} \leq 2V$
Power Dissipation (Note 3)	Internally Limited
Storage Temperature Range	$-65^{\circ}C$ to $+150^{\circ}C$

Lead Temperature (Soldering, 10 sec.)	$260^{\circ}C$
Maximum Junction Temperature (Note 3)	$150^{\circ}C$
Minimum ESD Rating (C = 100 pF, R = 1.5 k $\Omega$ )	2 kV

**Operating Ratings**

Supply Voltage	$4V \leq V_{IN} \leq 40V$
Output Switch Voltage	$0V \leq V_{SW} \leq 60V$
Output Switch Current	$I_{SW} \leq 3.0A$
Junction Temp. Range	$-40^{\circ}C \leq T_J \leq +125^{\circ}C$

**Electrical Characteristics**

Specifications with standard type face are for  $T_J = 25^{\circ}C$ , and those in **bold type face** apply over full **Operating Temperature Range**. Unless otherwise specified,  $V_{IN} = 5V$ .

**LM2586-3.3**

Symbol	Parameters	Conditions	Typical	Min	Max	Units
<b>SYSTEM PARAMETERS</b> Test Circuit of <i>Figure 1</i> (Note 4)						
$V_{OUT}$	Output Voltage	$V_{IN} = 4V$ to $12V$ $I_{LOAD} = 0.3$ to $1.2A$	3.3	3.17/ <b>3.14</b>	3.43/ <b>3.46</b>	V
$\Delta V_{OUT}/\Delta V_{IN}$	Line Regulation	$V_{IN} = 4V$ to $12V$ $I_{LOAD} = 0.3A$	20		50/ <b>100</b>	mV
$\Delta V_{OUT}/\Delta I_{LOAD}$	Load Regulation	$V_{IN} = 12V$ $I_{LOAD} = 0.3A$ to $1.2A$	20		50/ <b>100</b>	mV
$\eta$	Efficiency	$V_{IN} = 5V$ , $I_{LOAD} = 0.3A$	76			%
<b>UNIQUE DEVICE PARAMETERS</b> (Note 5)						
$V_{REF}$	Output Reference Voltage	Measured at Feedback Pin $V_{COMP} = 1.0V$	3.3	3.242/ <b>3.234</b>	3.358/ <b>3.366</b>	V
$\Delta V_{REF}$	Reference Voltage Line Regulation	$V_{IN} = 4V$ to $40V$	2.0			mV
$G_M$	Error Amp Transconductance	$I_{COMP} = -30 \mu A$ to $+30 \mu A$ $V_{COMP} = 1.0V$	1.193	<b>0.678</b>	<b>2.259</b>	mmho
$A_{VOL}$	Error Amp Voltage Gain	$V_{COMP} = 0.5V$ to $1.6V$ $R_{COMP} = 1.0 M\Omega$ (Note 6)	260	151/ <b>75</b>		V/V

**LM2586-5.0**

Symbol	Parameters	Conditions	Typical	Min	Max	Units
<b>SYSTEM PARAMETERS</b> Test Circuit of <i>Figure 1</i> (Note 4)						
$V_{OUT}$	Output Voltage	$V_{IN} = 4V$ to $12V$ $I_{LOAD} = 0.3A$ to $1.1A$	5.0	4.80/ <b>4.75</b>	5.20/ <b>5.25</b>	V
$\Delta V_{OUT}/\Delta V_{IN}$	Line Regulation	$V_{IN} = 4V$ to $12V$ $I_{LOAD} = 0.3A$	20		50/ <b>100</b>	mV
$\Delta V_{OUT}/\Delta I_{LOAD}$	Load Regulation	$V_{IN} = 12V$ $I_{LOAD} = 0.3A$ to $1.1A$	20		50/ <b>100</b>	mV
$\eta$	Efficiency	$V_{IN} = 12V$ , $I_{LOAD} = 0.6A$	80			%
<b>UNIQUE DEVICE PARAMETERS</b> (Note 5)						
$V_{REF}$	Output Reference Voltage	Measured at Feedback Pin $V_{COMP} = 1.0V$	5.0	4.913/ <b>4.900</b>	5.088/ <b>5.100</b>	V

**Electrical Characteristics** (Continued)**LM2586-5.0** (Continued)

Symbol	Parameters	Conditions	Typical	Min	Max	Units
$\Delta V_{REF}$	Reference Voltage Line Regulation	$V_{IN} = 4V$ to $40V$	3.3			mV
$G_M$	Error Amp Transconductance	$I_{COMP} = -30 \mu A$ to $+30 \mu A$ $V_{COMP} = 1.0V$	0.750	<b>0.447</b>	<b>1.491</b>	mmho
$A_{VOL}$	Error Amp Voltage Gain	$V_{COMP} = 0.5V$ to $1.6V$ $R_{COMP} = 1.0 M\Omega$ (Note 6)	165	<b>99/49</b>		V/V

**LM2586-12**

Symbol	Parameters	Conditions	Typical	Min	Max	Units
<b>SYSTEM PARAMETERS</b> Test Circuit of <i>Figure 2</i> (Note 4)						
$V_{OUT}$	Output Voltage	$V_{IN} = 4V$ to $10V$ $I_{LOAD} = 0.2A$ to $0.8A$	12.0	<b>11.52/11.40</b>	<b>12.48/12.60</b>	V
$\Delta V_{OUT}/\Delta V_{IN}$	Line Regulation	$V_{IN} = 4V$ to $10V$ $I_{LOAD} = 0.2A$	20		<b>100/200</b>	mV
$\Delta V_{OUT}/\Delta I_{LOAD}$	Load Regulation	$V_{IN} = 10V$ $I_{LOAD} = 0.2A$ to $0.8A$	20		<b>100/200</b>	mV
$\eta$	Efficiency	$V_{IN} = 10V$ , $I_{LOAD} = 0.6A$	93			%

**UNIQUE DEVICE PARAMETERS** (Note 5)

$V_{REF}$	Output Reference Voltage	Measured at Feedback Pin $V_{COMP} = 1.0V$	12.0	<b>11.79/11.76</b>	<b>12.21/12.24</b>	V
$\Delta V_{REF}$	Reference Voltage Line Regulation	$V_{IN} = 4V$ to $40V$	7.8			mV
$G_M$	Error Amp Transconductance	$I_{COMP} = -30 \mu A$ to $+30 \mu A$ $V_{COMP} = 1.0V$	0.328	<b>0.186</b>	<b>0.621</b>	mmho
$A_{VOL}$	Error Amp Voltage Gain	$V_{COMP} = 0.5V$ to $1.6V$ $R_{COMP} = 1.0 M\Omega$ (Note 6)	70	<b>41/21</b>		V/V

**LM2586-ADJ**

Symbol	Parameters	Conditions	Typical	Min	Max	Units
<b>SYSTEM PARAMETERS</b> Test Circuit of <i>Figure 2</i> (Note 4)						
$V_{OUT}$	Output Voltage	$V_{IN} = 4V$ to $10V$ $I_{LOAD} = 0.2A$ to $0.8A$	12.0	<b>11.52/11.40</b>	<b>12.48/12.60</b>	V
$\Delta V_{OUT}/\Delta V_{IN}$	Line Regulation	$V_{IN} = 4V$ to $10V$ $I_{LOAD} = 0.2A$	20		<b>100/200</b>	mV
$\Delta V_{OUT}/\Delta I_{LOAD}$	Load Regulation	$V_{IN} = 10V$ $I_{LOAD} = 0.2A$ to $0.8A$	20		<b>100/200</b>	mV
$\eta$	Efficiency	$V_{IN} = 10V$ , $I_{LOAD} = 0.6A$	93			%

**UNIQUE DEVICE PARAMETERS** (Note 5)

$V_{REF}$	Output Reference Voltage	Measured at Feedback Pin $V_{COMP} = 1.0V$	1.230	<b>1.208/1.205</b>	<b>1.252/1.255</b>	V
$\Delta V_{REF}$	Reference Voltage Line Regulation	$V_{IN} = 4V$ to $40V$	1.5			mV
$G_M$	Error Amp Transconductance	$I_{COMP} = -30 \mu A$ to $+30 \mu A$ $V_{COMP} = 1.0V$	3.200	<b>1.800</b>	<b>6.000</b>	mmho
$A_{VOL}$	Error Amp Voltage Gain	$V_{COMP} = 0.5V$ to $1.6V$ , $R_{COMP} = 1.0 M\Omega$ (Note 6)	670	<b>400/200</b>		V/V

**Electrical Characteristics** (Continued)**LM2586-ADJ** (Continued)

Symbol	Parameters	Conditions	Typical	Min	Max	Units
$I_B$	Error Amp Input Bias Current	$V_{COMP} = 1.0V$	125		425/600	nA
<b>COMMON DEVICE PARAMETERS for all versions</b> (Note 5)						
$I_S$	Input Supply Current	Switch Off (Note 8)	11		15.5/16.5	mA
		$I_{SWITCH} = 1.8A$	50		100/115	mA
$I_{S/D}$	Shutdown Input Supply Current	$V_{SH} = 3V$	16		100/300	$\mu A$
$V_{UV}$	Input Supply Undervoltage Lockout	$R_{LOAD} = 100\Omega$	3.30	3.05	3.75	V
$f_O$	Oscillator Frequency	Measured at Switch Pin $R_{LOAD} = 100\Omega$ , $V_{COMP} = 1.0V$ Freq. Adj. Pin Open (Pin 1)	100	85/75	115/125	kHz
		$R_{SET} = 22\text{ k}\Omega$	200			kHz
$f_{SC}$	Short-Circuit Frequency	Measured at Switch Pin $R_{LOAD} = 100\Omega$ $V_{FEEDBACK} = 1.15V$	25			kHz
$V_{EAO}$	Error Amplifier Output Swing	Upper Limit (Note 7)	2.8	2.6/2.4		V
		Lower Limit (Note 8)	0.25		0.40/0.55	V
$I_{EAO}$	Error Amp Output Current (Source or Sink)	(Note 9)	165	110/70	260/320	$\mu A$
$I_{SS}$	Soft Start Current	$V_{FEEDBACK} = 0.92V$ $V_{COMP} = 1.0V$	11.0	8.0/7.0	17.0/19.0	$\mu A$
$D_{MAX}$	Maximum Duty Cycle	$R_{LOAD} = 100\Omega$ (Note 7)	98	93/90		%
$I_L$	Switch Leakage Current	Switch Off $V_{SWITCH} = 60V$	15		300/600	$\mu A$
$V_{SUS}$	Switch Sustaining Voltage	$dV/dT = 1.5V/ns$		65		V
$V_{SAT}$	Switch Saturation Voltage	$I_{SWITCH} = 3.0A$	0.45		0.65/0.9	V
$I_{CL}$	NPN Switch Current Limit		4.0	3.0	7.0	A
$V_{STH}$	Synchronization Threshold Voltage	$F_{SYNC} = 200\text{ kHz}$ $V_{COMP} = 1V$ , $V_{IN} = 5V$	0.75	0.625/0.40	0.875/1.00	V
$I_{SYNC}$	Synchronization Pin Current	$V_{IN} = 5V$ $V_{COMP} = 1V$ , $V_{SYNC} = V_{STH}$	100		200	$\mu A$
$V_{SHTH}$	$\overline{ON/OFF}$ Pin (Pin 1) Threshold Voltage	$V_{COMP} = 1V$ (Note 10)	1.6	1.0/0.8	2.2/2.4	V
$I_{SH}$	$\overline{ON/OFF}$ Pin (Pin 1) Current	$V_{COMP} = 1V$ $V_{SH} = V_{SHTH}$	40	15/10	65/75	$\mu A$

## Electrical Characteristics (Continued)

### LM2586-ADJ (Continued)

Symbol	Parameters	Conditions	Typical	Min	Max	Units
<b>COMMON DEVICE PARAMETERS for all versions (Note 5)</b>						
$\theta_{JA}$	Thermal Resistance	T Package, Junction to Ambient (Note 11)	65			°C/W
$\theta_{JA}$		T Package, Junction to Ambient (Note 12)	45			
$\theta_{JC}$		T Package, Junction to Case	2			
$\theta_{JA}$		S Package, Junction to Ambient (Note 13)	56			
$\theta_{JA}$		S Package, Junction to Ambient (Note 14)	35			
$\theta_{JA}$		S Package, Junction to Ambient (Note 15)	26			
$\theta_{JC}$		S Package, Junction to Case	2			

**Note 1:** Absolute Maximum Ratings indicate limits beyond which damage to the device may occur. These ratings apply when the current is limited to less than 1.2 mA for pins 1, 2, 3, and 6. Operating ratings indicate conditions for which the device is intended to be functional, but device parameter specifications may not be guaranteed under these conditions. For guaranteed specifications and test conditions, see the Electrical Characteristics.

**Note 2:** Note that switch current and output current are not identical in a step-up regulator. Output current cannot be internally limited when the LM2586 is used as a step-up regulator. To prevent damage to the switch, the output current must be externally limited to 3A. However, output current is internally limited when the LM2586 is used as a flyback regulator (see the Application Hints section for more information).

**Note 3:** The junction temperature of the device ( $T_J$ ) is a function of the ambient temperature ( $T_A$ ), the junction-to-ambient thermal resistance ( $\theta_{JA}$ ), and the power dissipation of the device ( $P_D$ ). A thermal shutdown will occur if the temperature exceeds the maximum junction temperature of the device:  $P_D \times \theta_{JA} + T_{A(MAX)} \geq T_{J(MAX)}$ . For a safe thermal design, check that the maximum power dissipated by the device is less than:  $P_D \leq [T_{J(MAX)} - T_{A(MAX)}]/\theta_{JA}$ . When calculating the maximum allowable power dissipation, derate the maximum junction temperature—this ensures a margin of safety in the thermal design.

**Note 4:** External components such as the diode, inductor, input and output capacitors can affect switching regulator performance. When the LM2586 is used as shown in *Figures 1, 2*, system performance will be as specified by the system parameters.

**Note 5:** All room temperature limits are 100% production tested, and all limits at temperature extremes are guaranteed via correlation using standard Statistical Quality Control (SQC) methods.

**Note 6:** A 1.0 M $\Omega$  resistor is connected to the compensation pin (which is the error amplifier output) to ensure accuracy in measuring  $A_{VOL}$ .

**Note 7:** To measure this parameter, the feedback voltage is set to a low value, depending on the output version of the device, to force the error amplifier output high and the switch on.

**Note 8:** To measure this parameter, the feedback voltage is set to a high value, depending on the output version of the device, to force the error amplifier output low and the switch off.

**Note 9:** To measure the worst-case error amplifier output current, the LM2586 is tested with the feedback voltage set to its low value (Note 7) and at its high value (Note 8).

**Note 10:** When testing the minimum value, do not sink current from this pin— isolate it with a diode. If current is drawn from this pin, the frequency adjust circuit will begin operation (see *Figure 41*).

**Note 11:** Junction to ambient thermal resistance (no external heat sink) for the 7 lead TO-220 package mounted vertically, with 1/2 inch leads in a socket, or on a PC board with minimum copper area.

**Note 12:** Junction to ambient thermal resistance (no external heat sink) for the 7 lead TO-220 package mounted vertically, with 1/2 inch leads soldered to a PC board containing approximately 4 square inches of (1 oz.) copper area surrounding the leads.

**Note 13:** Junction to ambient thermal resistance for the 7 lead TO-263 mounted horizontally against a PC board area of 0.136 square inches (the same size as the TO-263 package) of 1 oz. (0.0014 in. thick) copper.

**Note 14:** Junction to ambient thermal resistance for the 7 lead TO-263 mounted horizontally against a PC board area of 0.4896 square inches (3.6 times the area of the TO-263 package) of 1 oz. (0.0014 in. thick) copper.

**Note 15:** Junction to ambient thermal resistance for the 7 lead TO-263 mounted horizontally against a PC board copper area of 1.0064 square inches (7.4 times the area of the TO-263 package) of 1 oz. (0.0014 in. thick) copper. Additional copper area will reduce thermal resistance further. See the thermal model in **Switchers Made Simple**® software.

# Typical Performance Characteristics

**Supply Current vs Temperature**

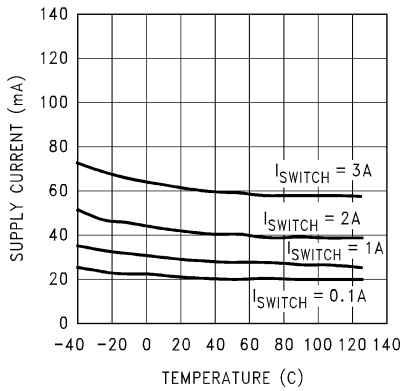

01251602

**Reference Voltage vs Temperature**

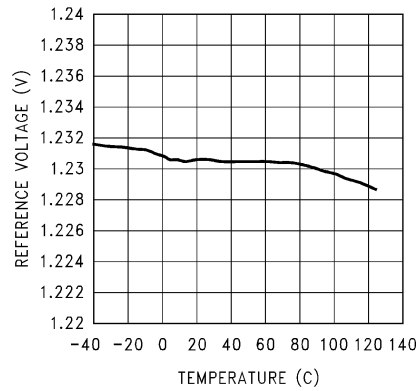

01251603

**ΔReference Voltage vs Supply Voltage**

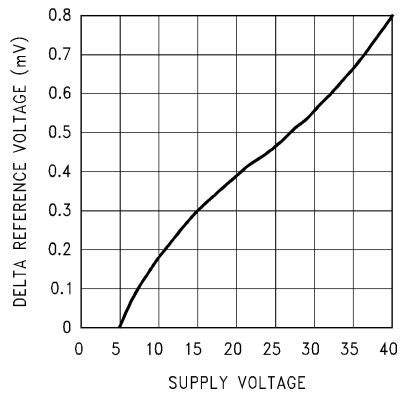

01251604

**Supply Current vs Switch Current**

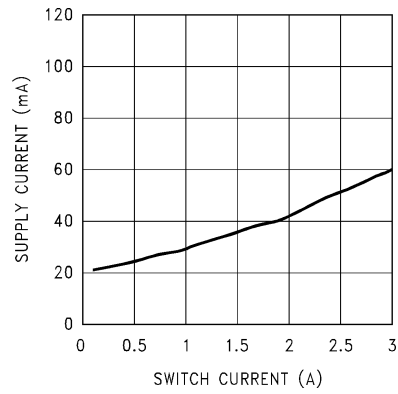

01251605

**Current Limit vs Temperature**

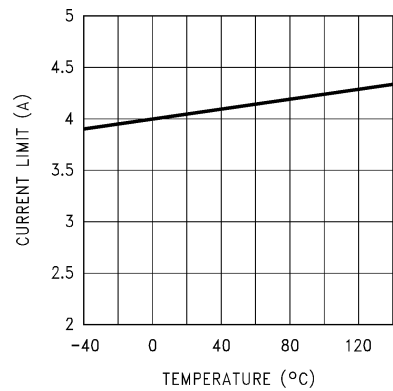

01251606

**Feedback Pin Bias Current vs Temperature**

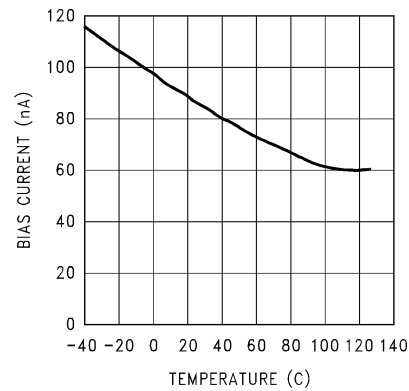

01251607



# Typical Performance Characteristics (Continued)

**Switch Saturation Voltage vs Temperature**

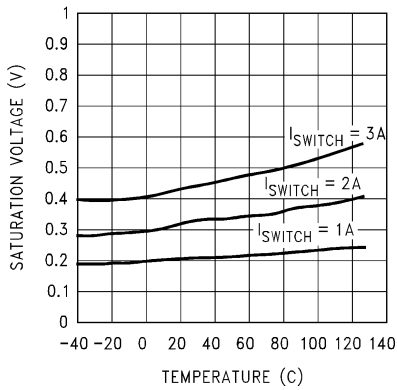

01251608

**Switch Transconductance vs Temperature**

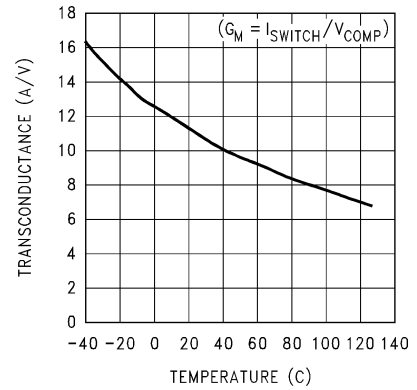

01251609

**Oscillator Frequency vs Temperature**

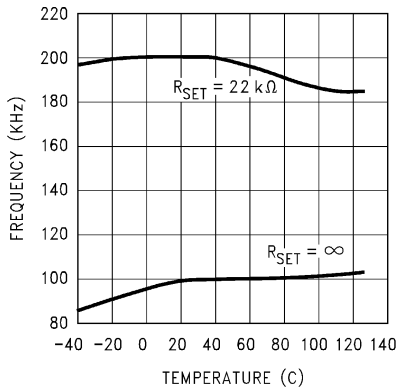

01251610

**Error Amp Transconductance vs Temperature**

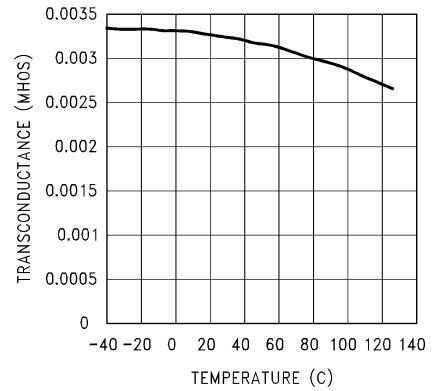

01251611

**Error Amp Voltage Gain vs Temperature**

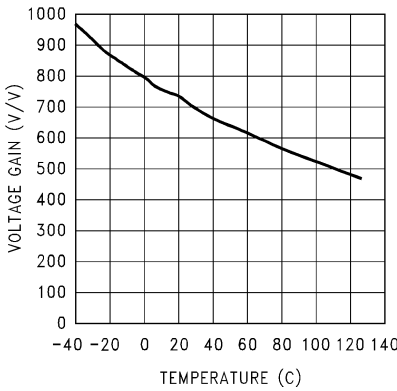

01251612

**Short Circuit Frequency vs Temperature**

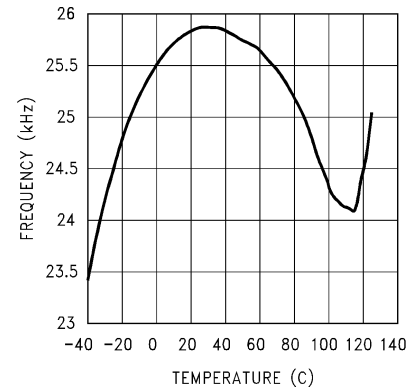

01251613

# Typical Performance Characteristics (Continued)

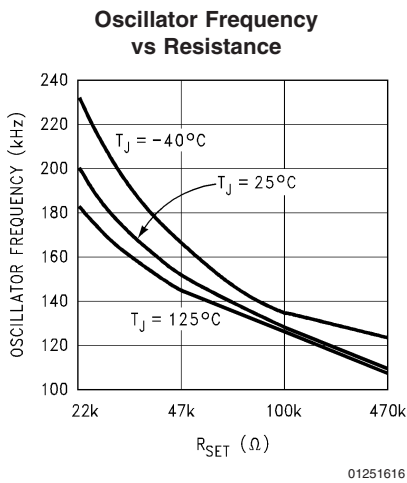
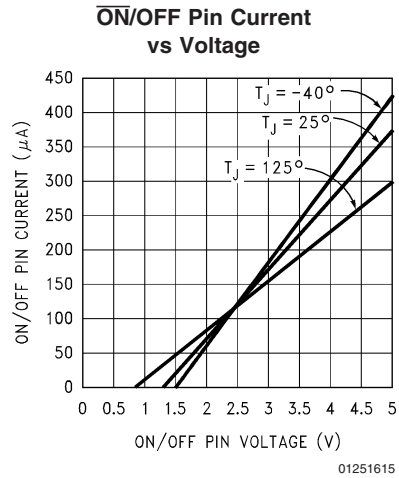
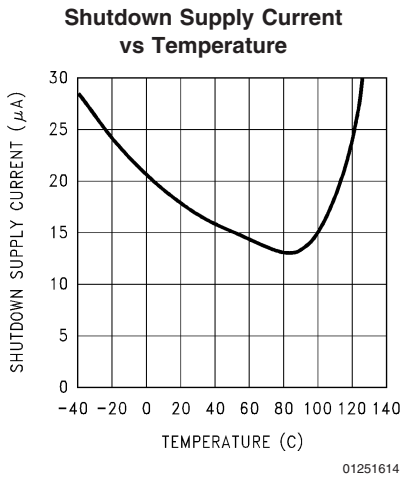

## Flyback Regulator

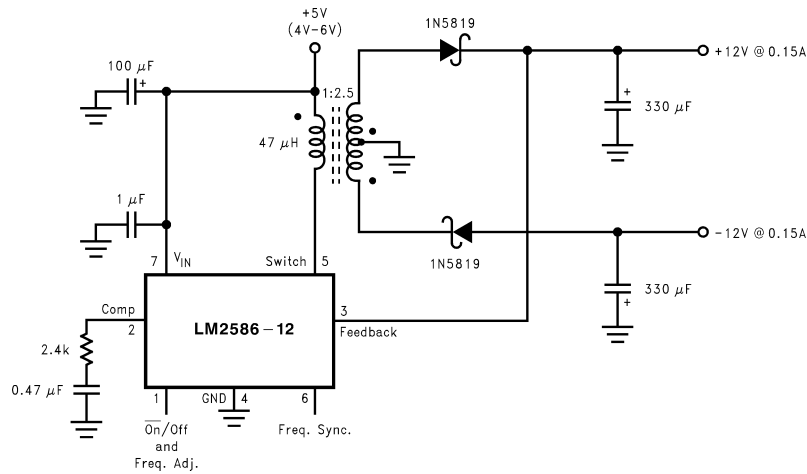

## Test Circuits

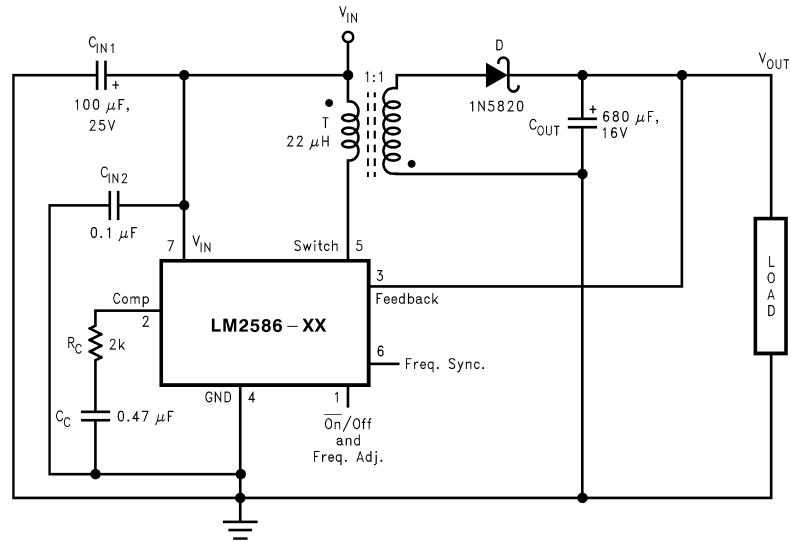

01251621

$C_{IN1}$ —100  $\mu\text{F}$ , 25V Aluminum Electrolytic  
 $C_{IN2}$ —0.1  $\mu\text{F}$  Ceramic  
 $T$ —22  $\mu\text{H}$ , 1:1 Schott #67141450  
 $D$ —1N5820  
 $C_{OUT}$ —680  $\mu\text{F}$ , 16V Aluminum Electrolytic  
 $C_C$ —0.47  $\mu\text{F}$  Ceramic  
 $R_C$ —2k

FIGURE 1. LM2586-3.3 and LM2586-5.0

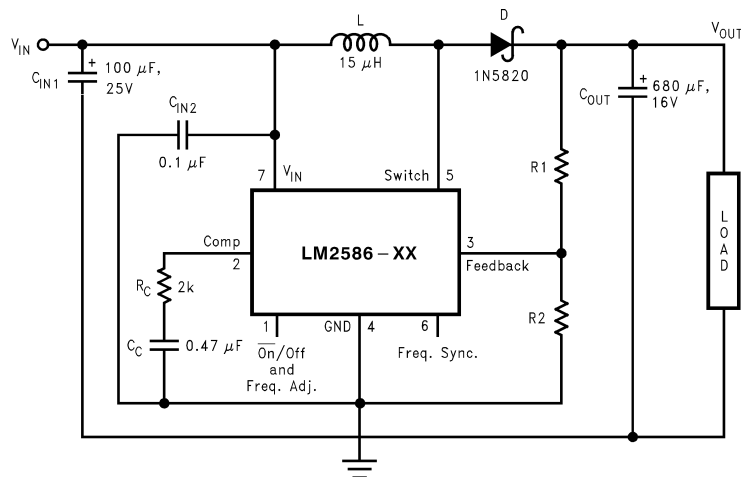

01251622

$C_{IN1}$ —100  $\mu\text{F}$ , 25V Aluminum Electrolytic  
 $C_{IN2}$ —0.1  $\mu\text{F}$  Ceramic  
 $L$ —15  $\mu\text{H}$ , Renco #RL-5472-5  
 $D$ —1N5820  
 $C_{OUT}$ —680  $\mu\text{F}$ , 16V Aluminum Electrolytic  
 $C_C$ —0.47  $\mu\text{F}$  Ceramic  
 $R_C$ —2k  
 For 12V Devices:  $R_1$  = Short ( $0\Omega$ ) and 2 = Open  
 For ADJ Devices:  $R_1$  = 48.75k,  $\pm 0.1\%$  and 2 = 5.62k,  $\pm 0.1\%$

FIGURE 2. LM2586-12 and LM2586-ADJ

## Block Diagram

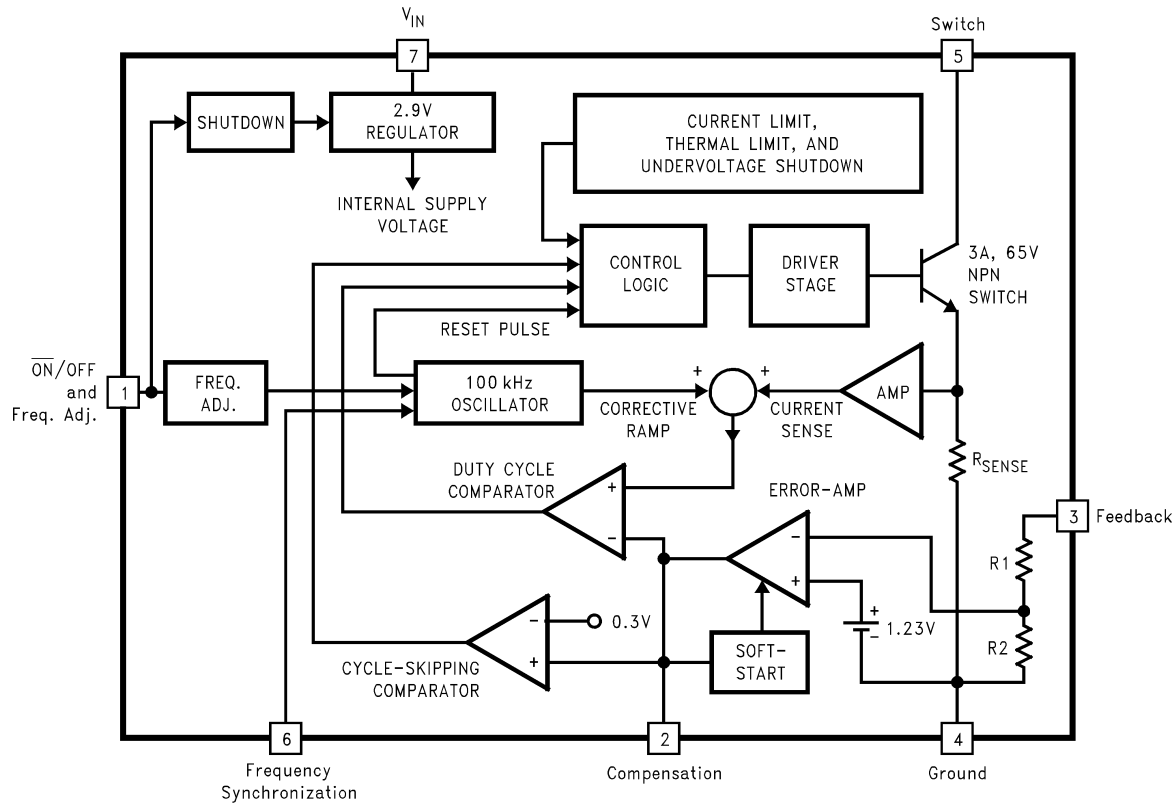

01251623

For Fixed Versions

3.3V, R1 = 3.4k, R2 = 2k

5.0V, R1 = 6.15k, R2 = 2k

12V, R1 = 8.73k, R2 = 1k

For Adj. Version

R1 = Short (0 $\Omega$ ), R2 = Open

FIGURE 3. Block Diagram

## Flyback Regulator Operation

The LM2586 is ideally suited for use in the flyback regulator topology. The flyback regulator can produce a single output voltage, such as the one shown in *Figure 4*, or multiple output voltages. In *Figure 4*, the flyback regulator generates an output voltage that is inside the range of the input voltage. This feature is unique to flyback regulators and cannot be duplicated with buck or boost regulators.

The operation of a flyback regulator is as follows (refer to *Figure 4*): when the switch is on, current flows through the primary winding of the transformer, T1, storing energy in the magnetic field of the transformer. Note that the primary and secondary windings are out of phase, so no current flows through the secondary when current flows through the primary. When the switch turns off, the magnetic field col-

lapses, reversing the voltage polarity of the primary and secondary windings. Now rectifier D1 is forward biased and current flows through it, releasing the energy stored in the transformer. This produces voltage at the output.

The output voltage is controlled by modulating the peak switch current. This is done by feeding back a portion of the output voltage to the error amp, which amplifies the difference between the feedback voltage and a 1.230V reference. The error amp output voltage is compared to a ramp voltage proportional to the switch current (i.e., inductor current during the switch on time). The comparator terminates the switch on time when the two voltages are equal, thereby controlling the peak switch current to maintain a constant output voltage.

## Flyback Regulator Operation (Continued)

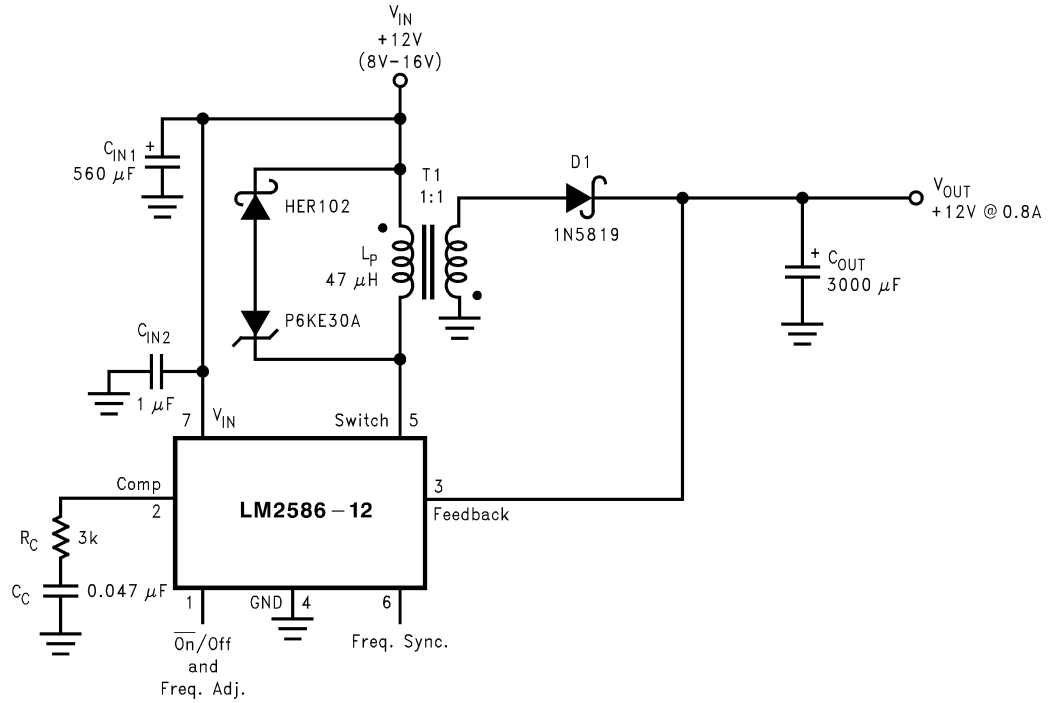

01251624

As shown in Figure 4, the LM2586 can be used as a flyback regulator by using a minimum number of external components. The switching waveforms of this regulator are shown in Figure 5. Typical Performance Characteristics observed during the operation of this circuit are shown in Figure 6.

FIGURE 4. 12V Flyback Regulator Design Example

## Typical Performance Characteristics

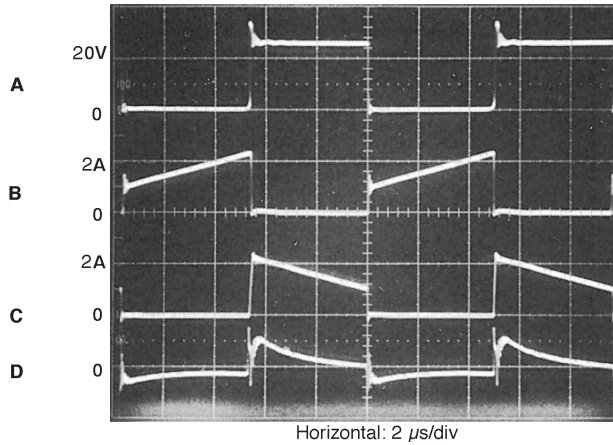

01251665

- A: Switch Voltage, 20V/div
- B: Switch Current, 2A/div
- C: Output Rectifier Current, 2A/div
- D: Output Ripple Voltage, 50 mV/div AC-Coupled

FIGURE 5. Switching Waveforms

## Typical Performance Characteristics (Continued)

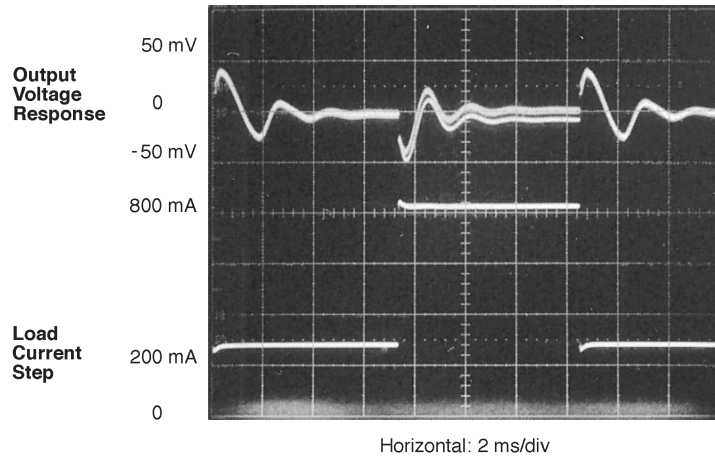

01251666

FIGURE 6.  $V_{OUT}$  Response to Load Current Step

## Typical Flyback Regulator Applications

Figure 7 through Figure 12 show six typical flyback applications, varying from single output to triple output. Each drawing contains the part number(s) and manufacturer(s) for every component except the transformer. For the transformer part numbers and manufacturers' names, see the

table in Figure 13. For applications with different output voltages—requiring the LM2586-ADJ—or different output configurations that do not match the standard configurations, refer to the **Switchers Made Simple** software.

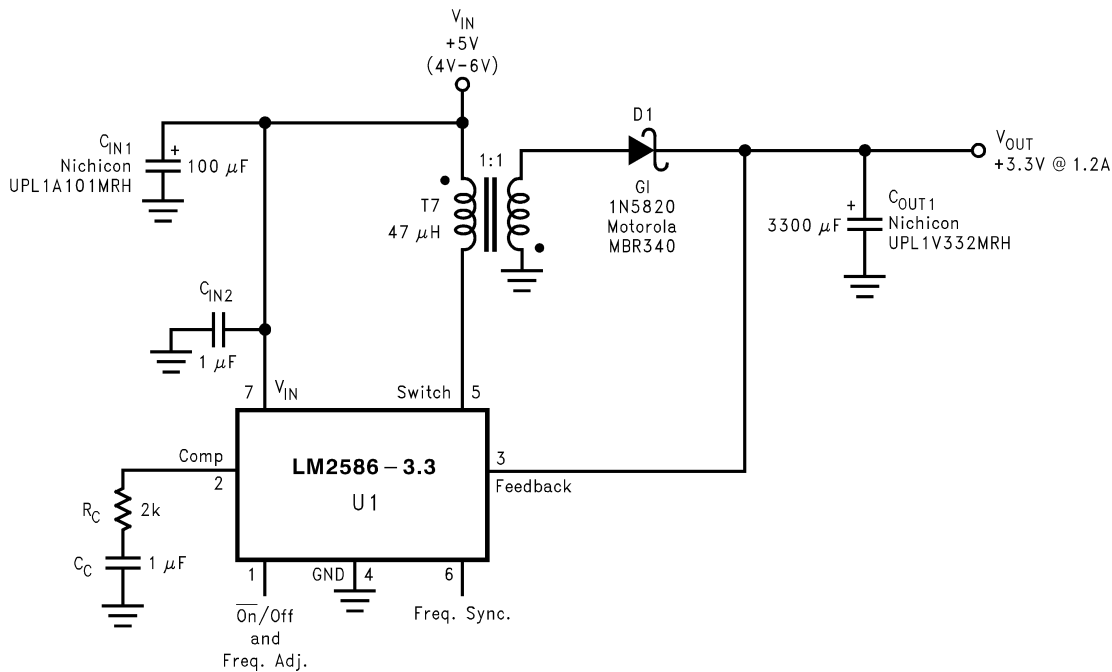

01251627

FIGURE 7. Single-Output Flyback Regulator

Typical Flyback Regulator Applications (Continued)

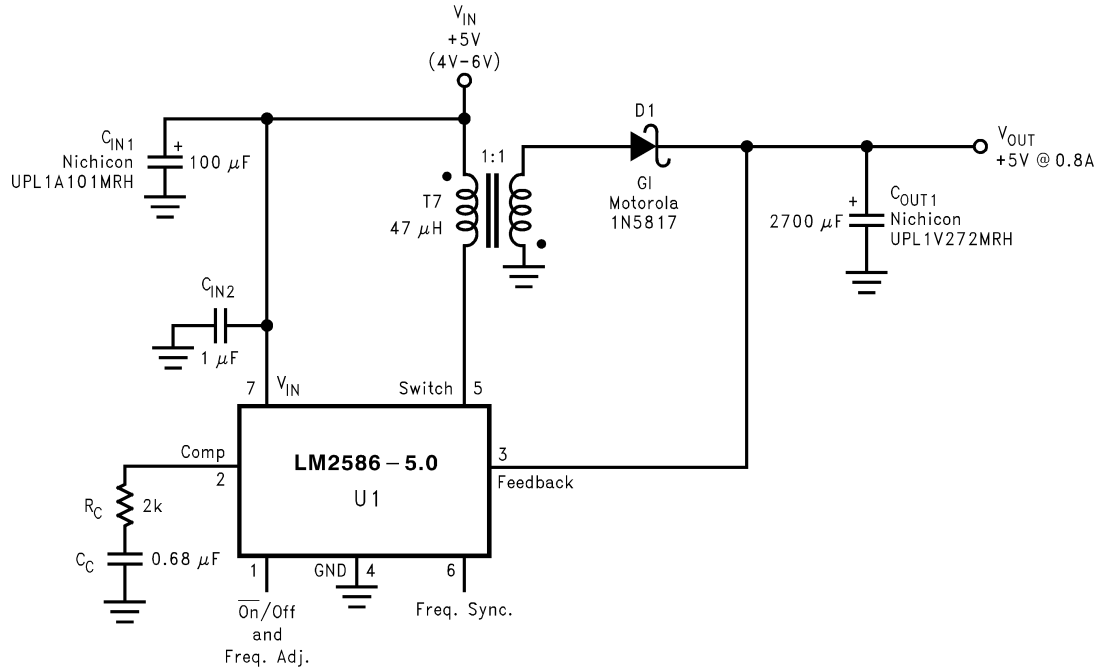

01251628

FIGURE 8. Single-Output Flyback Regulator

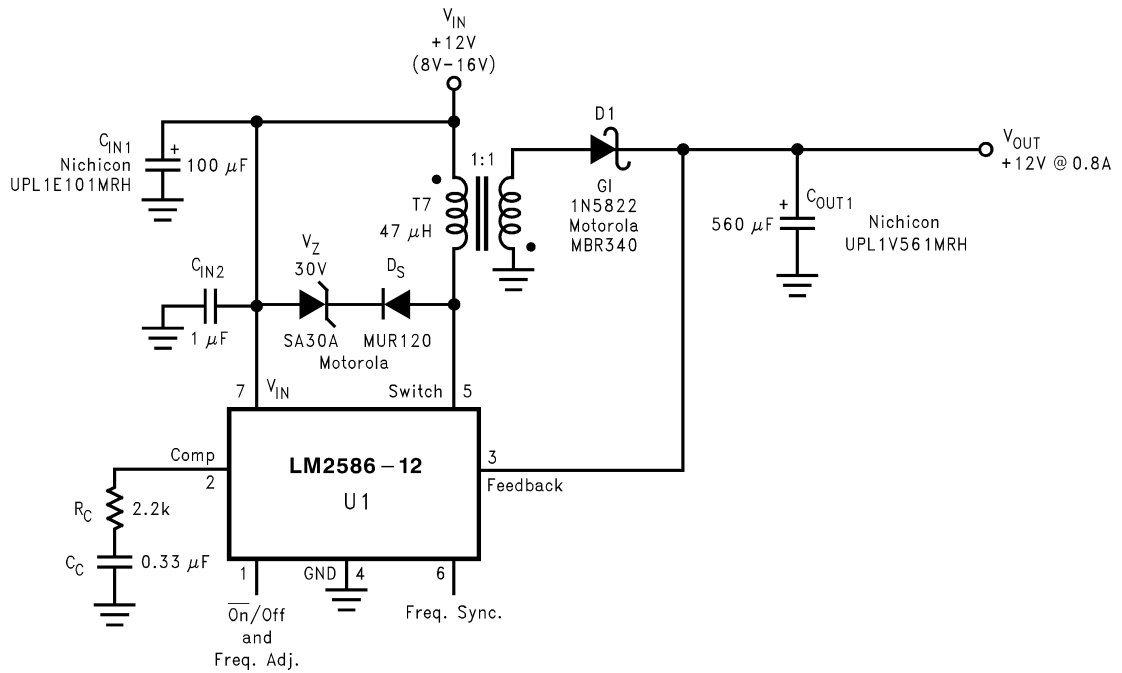

01251629

FIGURE 9. Single-Output Flyback Regulator

Typical Flyback Regulator Applications (Continued)

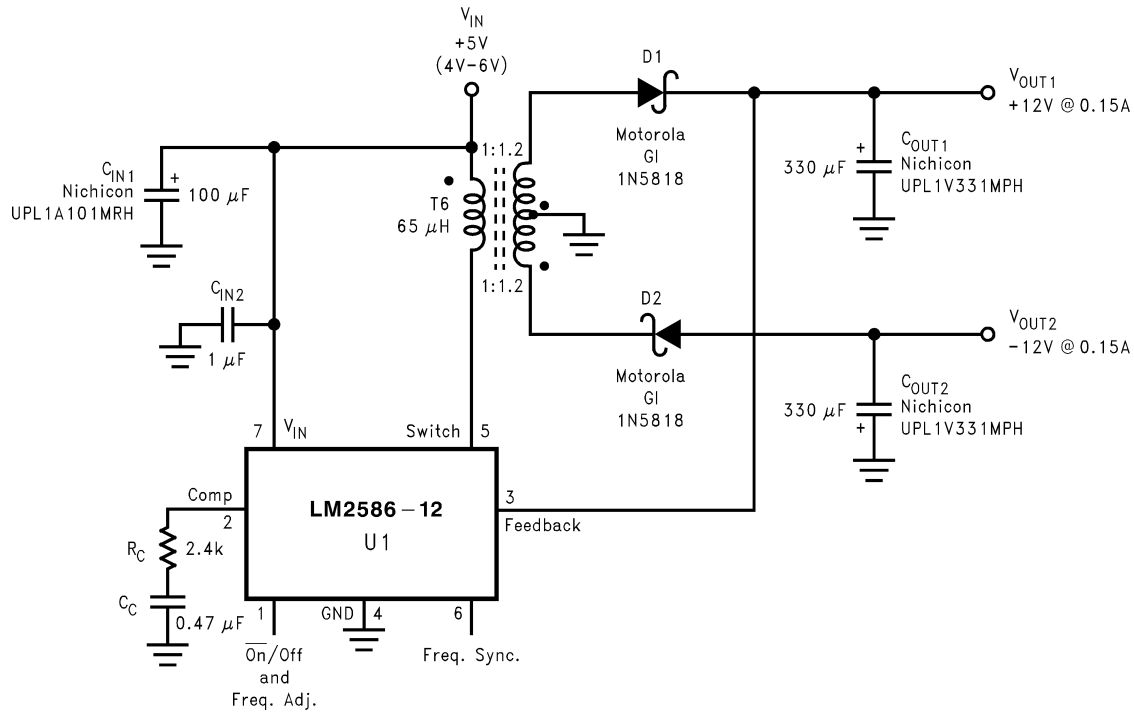

01251630

FIGURE 10. Dual-Output Flyback Regulator

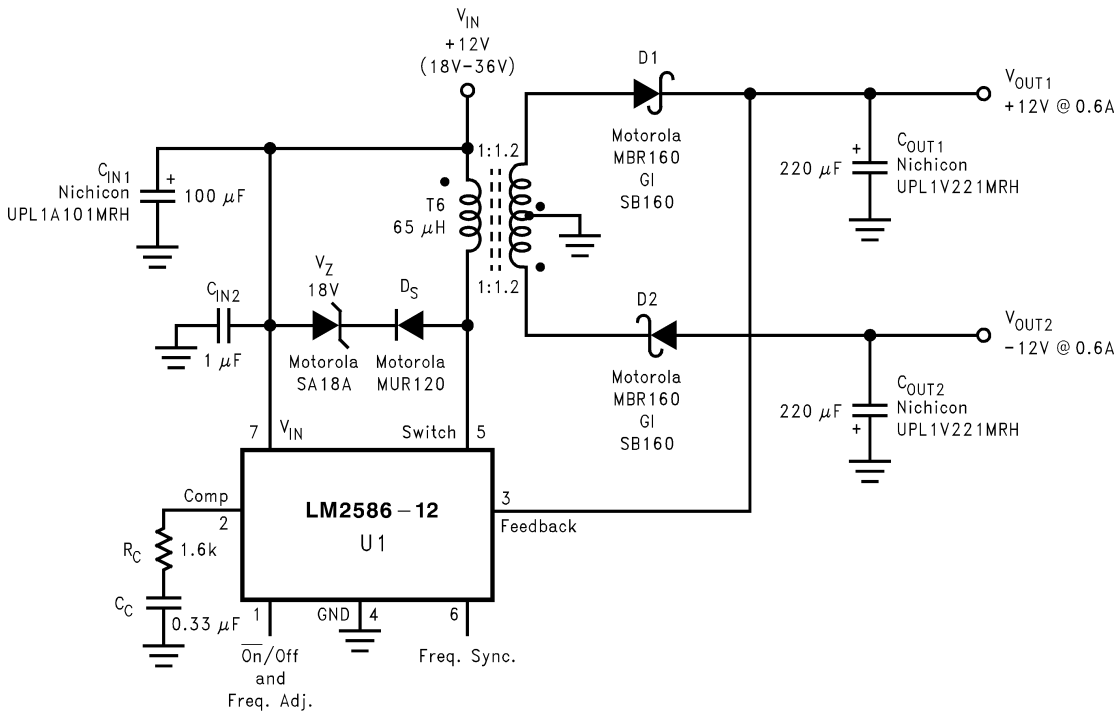

01251631

FIGURE 11. Dual-Output Flyback Regulator



Typical Flyback Regulator Applications (Continued)

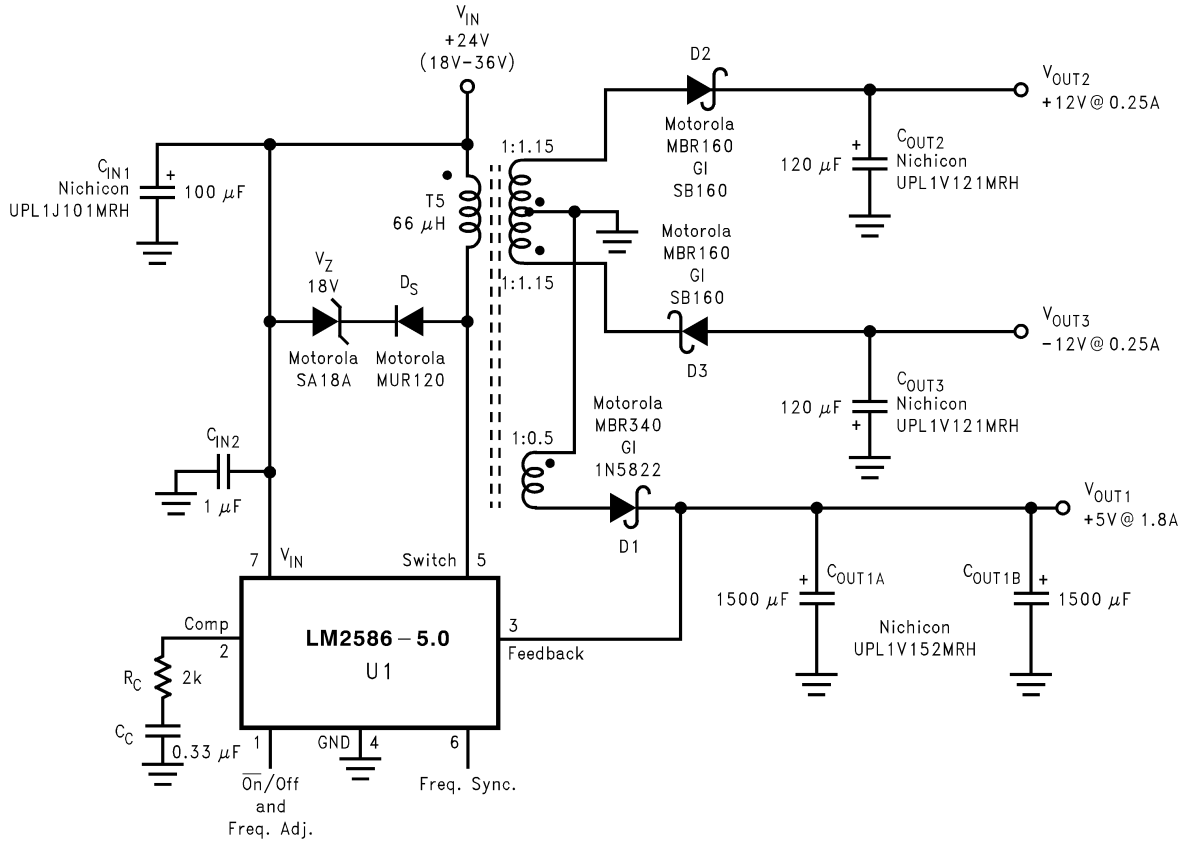

01251632

FIGURE 12. Triple-Output Flyback Regulator

TRANSFORMER SELECTION (T)

Figure 13 lists the standard transformers available for flyback regulator applications. Included in the table are the turns ratio(s) for each transformer, as well as the output voltages, input voltage ranges, and the maximum load currents for each circuit.

Applications	Figure 7	Figure 8	Figure 9	Figure 10	Figure 11	Figure 12
Transformers	T7	T7	T7	T6	T6	T5
V <sub>IN</sub>	4V-6V	4V-6V	8V-16V	4V-6V	18V-36V	18V-36V
V <sub>OUT1</sub>	3.3V	5V	12V	12V	12V	5V
I <sub>OUT1</sub> (Max)	1.4A	1A	0.8A	0.15A	0.6A	1.8A
N <sub>1</sub>	1	1	1	1.2	1.2	0.5
V <sub>OUT2</sub>				-12V	-12V	12V
I <sub>OUT2</sub> (Max)				0.15A	0.6A	0.25A
N <sub>2</sub>				1.2	1.2	1.15
V <sub>OUT3</sub>						-12V
I <sub>OUT3</sub> (Max)						0.25A
N <sub>3</sub>						1.15

FIGURE 13. Transformer Selection Table

# Typical Flyback Regulator Applications (Continued)

Transformer Type	Manufacturers' Part Numbers					
	Coilcraft (Note 16)	Coilcraft (Note 16) Surface Mount	Pulse (Note 17) Surface Mount	Pulse (Note 17)	Renco (Note 18)	Schott (Note 19)
T5	Q4338-B	Q4437-B	PE-68413	—	RL-5532	67140890
T6	Q4339-B	Q4438-B	PE-68414	—	RL-5533	67140900
T7	S6000-A	S6057-A	—	PE-68482	RL-5751	26606

**Note 16:** Coilcraft Inc., Phone: (800) 322-2645  
 1102 Silver Lake Road, Cary, IL 60013 Fax: (708) 639-1469  
 European Headquarters, 21 Napier Place Phone: +44 1236 730 595  
 Wardpark North, Cumbernauld, Scotland G68 0LL Fax: +44 1236 730 627

**Note 17:** Pulse Engineering Inc., Phone: (619) 674-8100  
 12220 World Trade Drive, San Diego, CA 92128 Fax: (619) 674-8262  
 European Headquarters, Dunmore Road Phone: +353 93 24 107  
 Tuam, Co. Galway, Ireland Fax: +353 93 24 459

**Note 18:** Renco Electronics Inc., Phone: (800) 645-5828  
 60 Jeffryn Blvd. East, Deer Park, NY 11729 Fax: (516) 586-5562

**Note 19:** Schott Corp., Phone: (612) 475-1173  
 1000 Parkers Lane Road, Wayzata, MN 55391 Fax: (612) 475-1786

**FIGURE 14. Transformer Manufacturer Guide**

## TRANSFORMER FOOTPRINTS

Figure 15 through Figure 29 show the footprints of each transformer, listed in Figure 14.

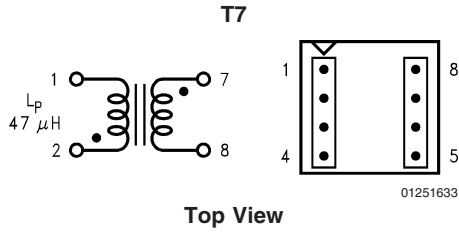

**FIGURE 15. Coilcraft S6000-A**

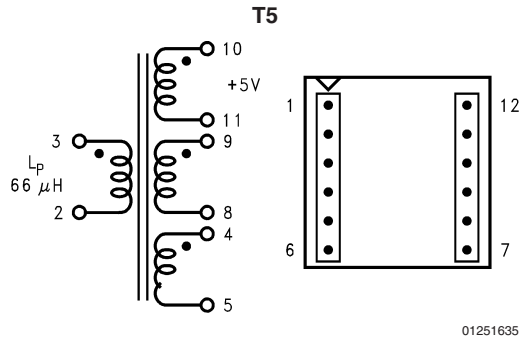

**FIGURE 17. Coilcraft Q4437-B (Surface Mount)**

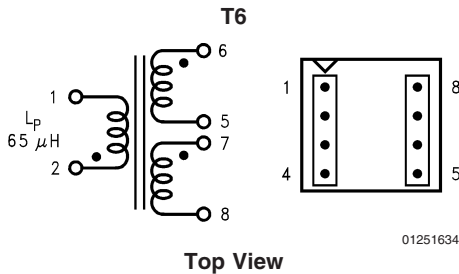

**FIGURE 16. Coilcraft Q4339-B**

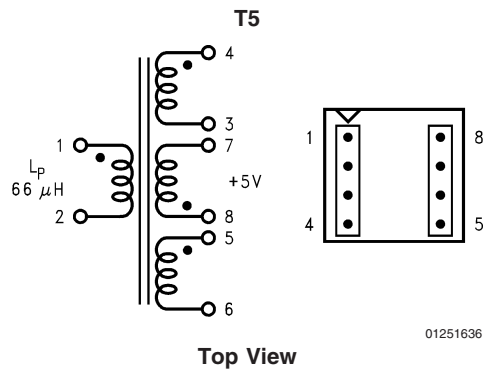

**FIGURE 18. Coilcraft Q4338-B**

# Typical Flyback Regulator Applications (Continued)

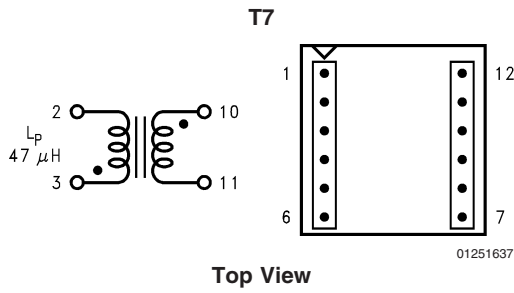

FIGURE 19. Coilcraft S6057-A (Surface Mount)

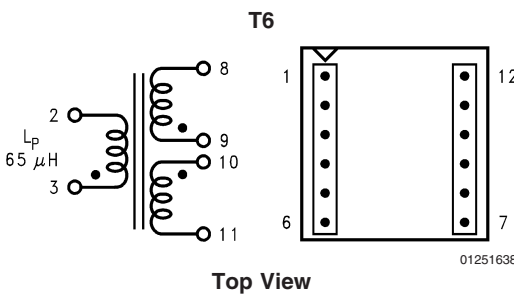

FIGURE 20. Coilcraft Q4438-B (Surface Mount)

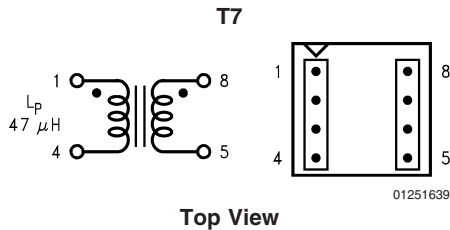

FIGURE 21. Pulse PE-68482

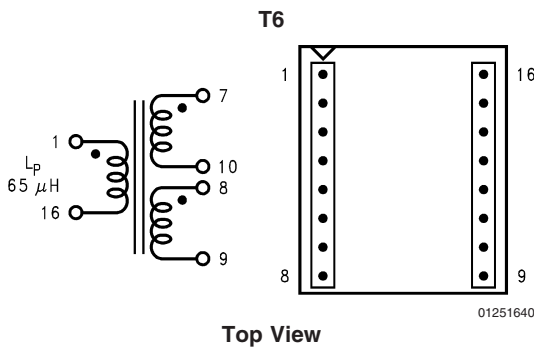

FIGURE 22. Pulse PE-68414 (Surface Mount)

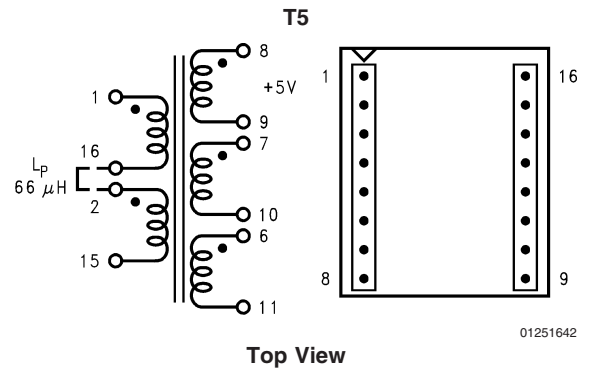

FIGURE 23. Pulse PE-68413 (Surface Mount)

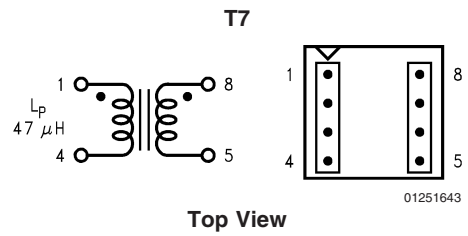

FIGURE 24. Renco RL-5751

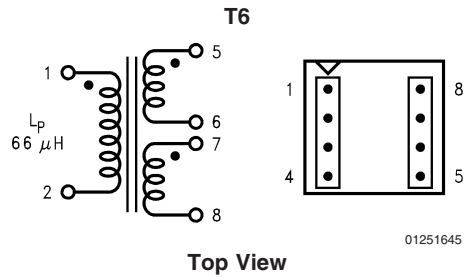

FIGURE 25. Renco RL-5533

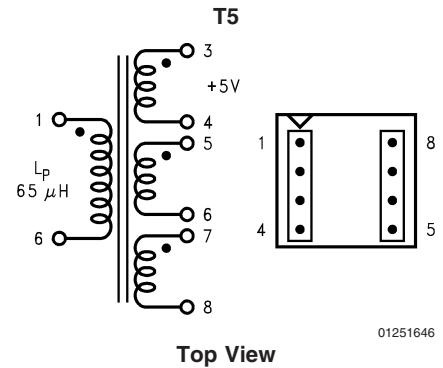

FIGURE 26. Renco RL-5532

# Typical Flyback Regulator Applications (Continued)

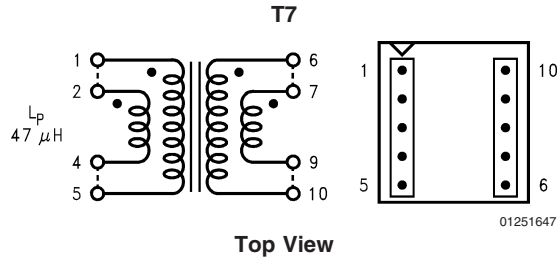

FIGURE 27. Schott 26606

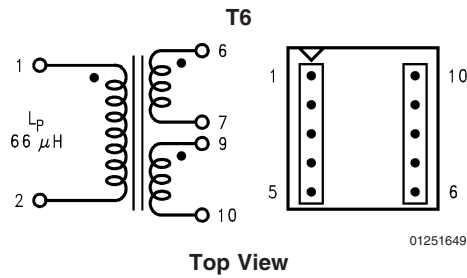

FIGURE 28. Schott 67140900

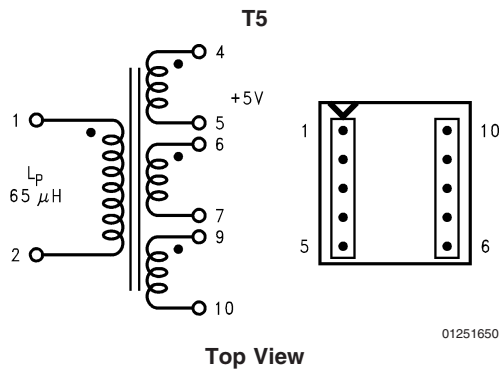

FIGURE 29. Schott 67140890

## Step-Up (Boost) Regulator Operation

Figure 30 shows the LM2586 used as a step-up (boost) regulator. This is a switching regulator that produces an output voltage greater than the input supply voltage.

A brief explanation of how the LM2586 Boost Regulator works is as follows (refer to Figure 30). When the NPN switch turns on, the inductor current ramps up at the rate of  $V_{IN}/L$ , storing energy in the inductor. When the switch turns off, the lower end of the inductor flies above  $V_{IN}$ , discharging its current through diode (D) into the output capacitor ( $C_{OUT}$ ) at a rate of  $(V_{OUT} - V_{IN})/L$ . Thus, energy stored in the inductor during the switch on time is transferred to the output during the switch off time. The output voltage is controlled by adjusting the peak switch current, as described in the flyback regulator section.

## Step-Up (Boost) Regulator Operation (Continued)

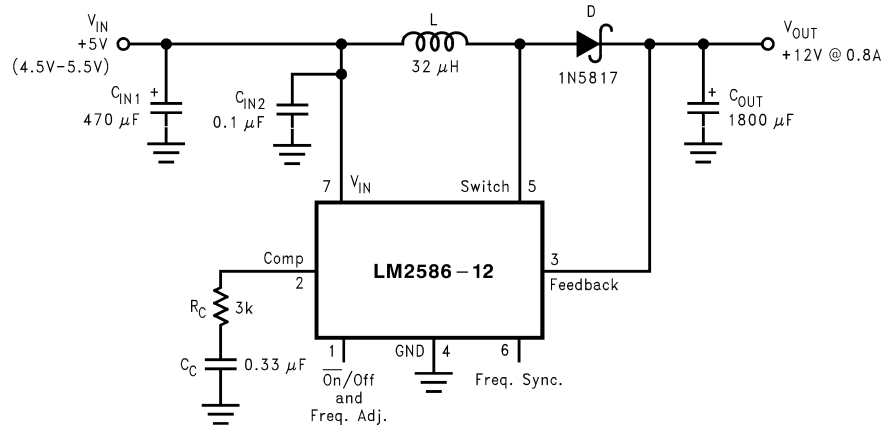

01251651

**FIGURE 30. 12V Boost Regulator**

By adding a small number of external components (as shown in *Figure 30*), the LM2586 can be used to produce a regulated output voltage that is greater than the applied input

voltage. The switching waveforms observed during the operation of this circuit are shown in *Figure 31*. Typical performance of this regulator is shown in *Figure 32*.

## Typical Performance Characteristics

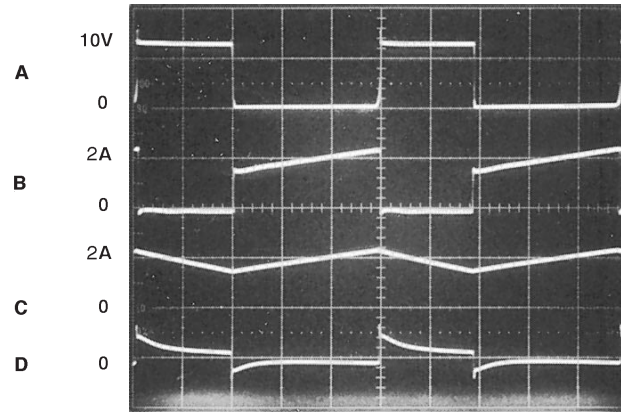
Horizontal: 2  $\mu$ s/div

01251667

- A: Switch Voltage, 10V/div  
 B: Switch Current, 2A/div  
 C: Inductor Current, 2A/div  
 D: Output Ripple Voltage, 100 mV/div, AC-Coupled

FIGURE 31. Switching Waveforms

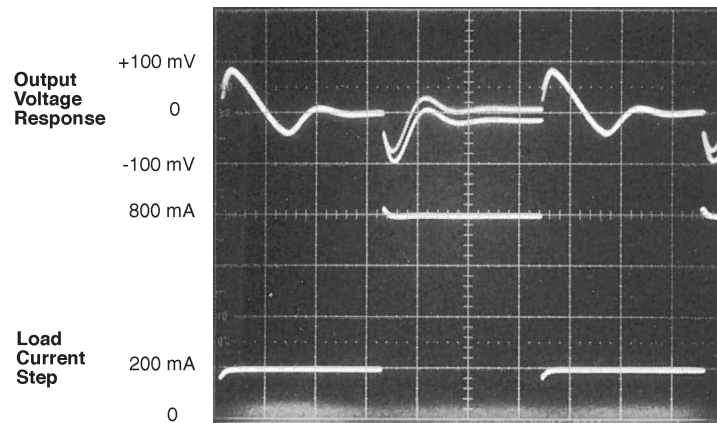

Horizontal: 2 ms/div

01251668

FIGURE 32.  $V_{OUT}$  Response to Load Current Step

## Typical Boost Regulator Applications

Figures 33, 35 through Figure 37 show four typical boost applications—one fixed and three using the adjustable version of the LM2586. Each drawing contains the part num-

ber(s) and manufacturer(s) for every component. For the fixed 12V output application, the part numbers and manufacturers' names for the inductor are listed in a table in Figure 34. For applications with different output voltages, refer to the **Switchers Made Simple** software.

## Typical Boost Regulator Applications (Continued)

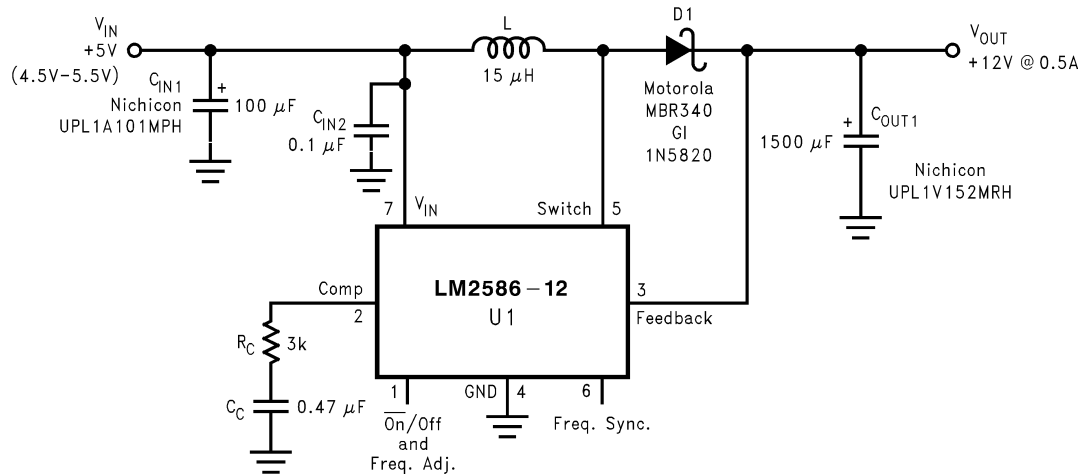

01251654

**FIGURE 33. +5V to +12V Boost Regulator**

Figure 34 contains a table of standard inductors, by part number and corresponding manufacturer, for the fixed output regulator of Figure 33.

Coilcraft (Note 20)	Pulse (Note 21)	Renco (Note 22)	Schott (Note 23)	Schott (Note 23) (Surface Mount)
DO3316-153	PE-53898	RL-5471-7	67146510	67146540

**Note 20:** Coilcraft Inc., Phone: (800) 322-2645

1102 Silver Lake Road, Cary, IL 60013 Fax: (708) 639-1469

European Headquarters, 21 Napier Place Phone: +44 1236 730 595

Wardpark North, Cumbernauld, Scotland G68 0LL Fax: +44 1236 730 627

**Note 21:** Pulse Engineering Inc., Phone: (619) 674-8100

12220 World Trade Drive, San Diego, CA 92128 Fax: (619) 674-8262

European Headquarters, Dunmore Road Phone: +353 93 24 107

Tuam, Co. Galway, Ireland Fax: +353 93 24 459

**Note 22:** Renco Electronics Inc., Phone: (800) 645-5828

60 Jeffryn Blvd. East, Deer Park, NY 11729 Fax: (516) 586-5562

**Note 23:** Schott Corp., Phone: (612) 475-1173

1000 Parkers Lane Road, Wayzata, MN 55391 Fax: (612) 475-1786

**FIGURE 34. Inductor Selection Table**

Typical Boost Regulator Applications (Continued)

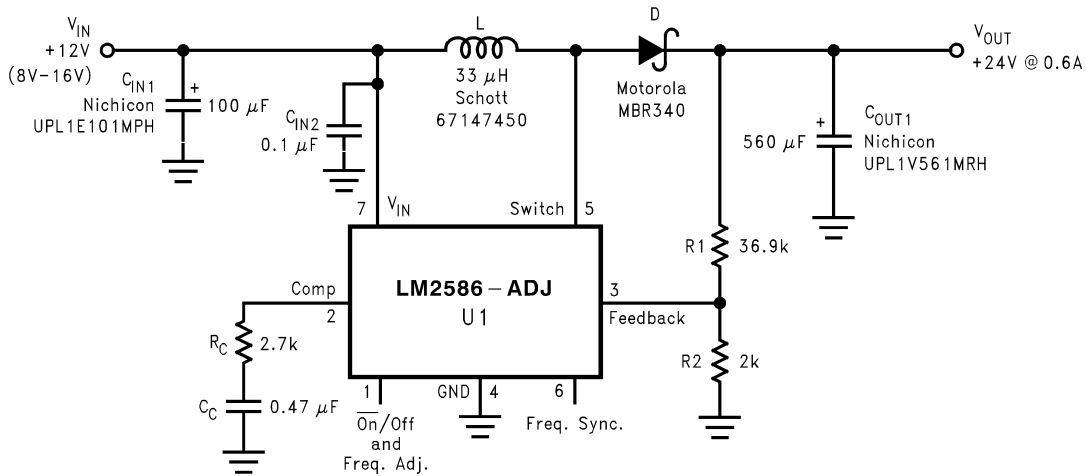

01251655

FIGURE 35. +12V to +24V Boost Regulator

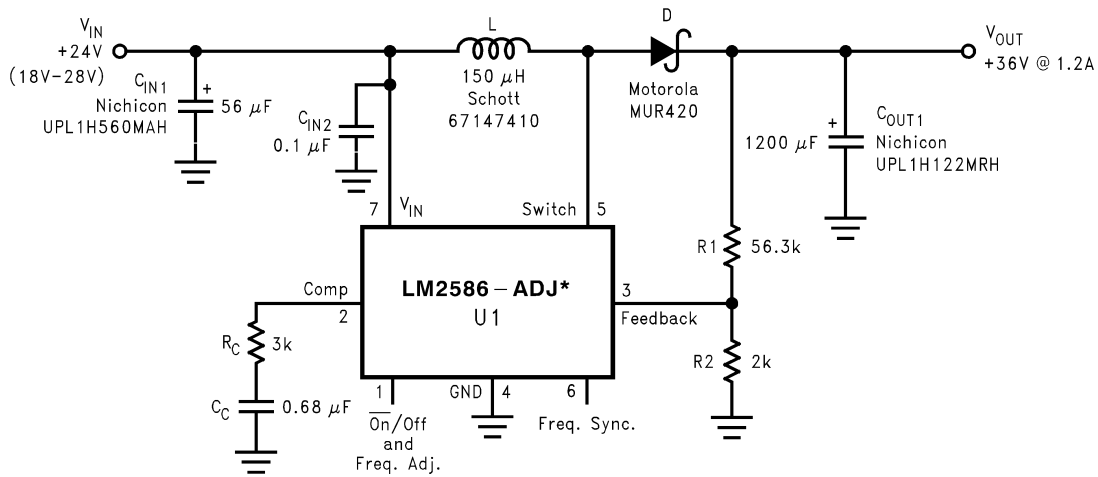

01251656

FIGURE 36. +24V to +36V Boost Regulator



## Typical Boost Regulator Applications (Continued)

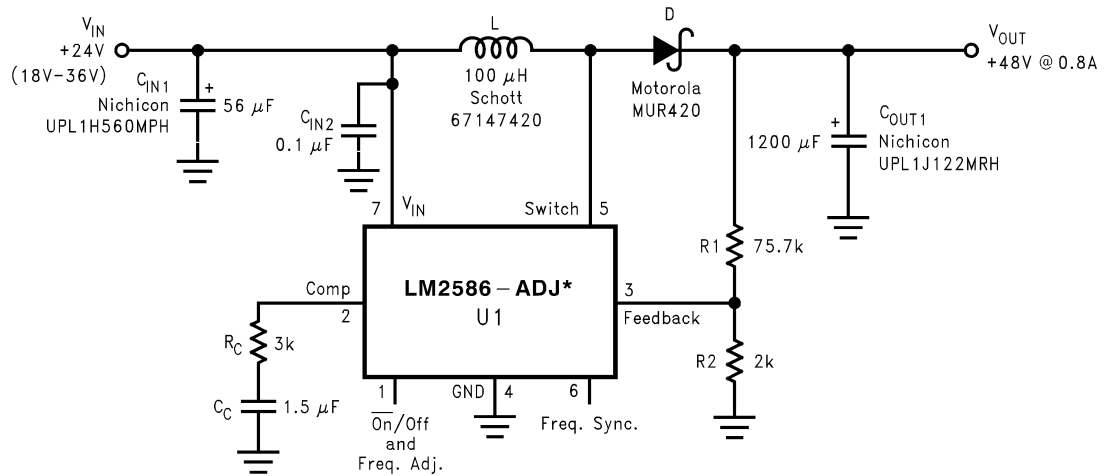

01251657

FIGURE 37. +24V to +48V Boost Regulator

**Note 24:** The LM2586 will require a heat sink in these applications. The size of the heat sink will depend on the maximum ambient temperature. To calculate the thermal resistance of the IC and the size of the heat sink needed, see the "Heat Sink/Thermal Considerations" section in the Application Hints.

## Application Hints

### LM2586 SPECIAL FEATURES

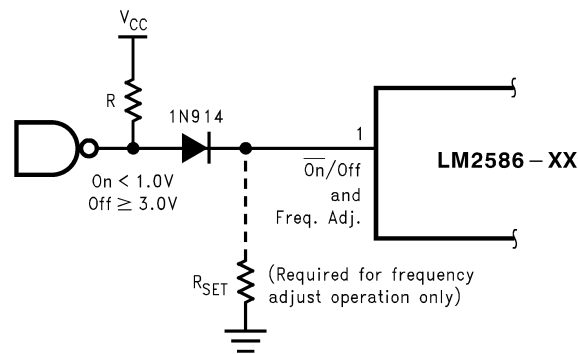

01251658

FIGURE 38. Shutdown Operation

### SHUTDOWN CONTROL

A feature of the LM2586 is its ability to be shut down using the  $\overline{\text{ON}}/\text{OFF}$  pin (pin 1). This feature conserves input power by turning off the device when it is not in use. For proper operation, an isolation diode is required (as shown in *Figure 38*).

The device will shut down when 3V or greater is applied on the  $\overline{\text{ON}}/\text{OFF}$  pin, sourcing current into pin 1. In shut down mode, the device will draw typically 56  $\mu\text{A}$  of supply current (16  $\mu\text{A}$  to  $V_{\text{IN}}$  and 40  $\mu\text{A}$  to the  $\overline{\text{ON}}/\text{OFF}$  pin). To turn the device back on, leave pin 1 floating, using an (isolation) diode, as shown in *Figure 38* (for normal operation, do not source or sink current to or from this pin—see the next section).

### FREQUENCY ADJUSTMENT

The switching frequency of the LM2586 can be adjusted with the use of an external resistor. This feature allows the user to optimize the size of the magnetics and the output capacitor(s) by tailoring the operating frequency. A resistor connected from pin 1 (the Freq. Adj. pin) to ground will set the switching frequency from 100 kHz to 200 kHz (maximum). As shown in *Figure 38*, the pin can be used to adjust the frequency while still providing the shut down function. A curve in the Performance Characteristics Section graphs the resistor value to the corresponding switching frequency. The table in *Figure 39* shows resistor values corresponding to commonly used frequencies.

However, changing the LM2586's operating frequency from its nominal value of 100 kHz will change the magnetics selection and compensation component values.

## Application Hints (Continued)

R <sub>SET</sub> (kΩ)	Frequency (kHz)
Open	100
200	125
47	150
33	175
22	200

FIGURE 39. Frequency Setting Resistor Guide

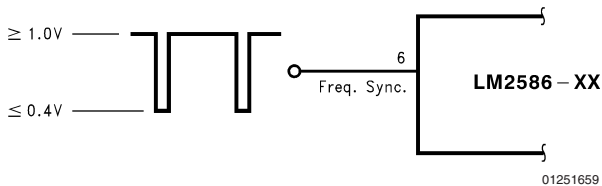

FIGURE 40. Frequency Synchronization

### FREQUENCY SYNCHRONIZATION

Another feature of the LM2586 is the ability to synchronize the switching frequency to an external source, using the sync pin (pin 6). This feature allows the user to parallel multiple devices to deliver more output power.

A negative falling pulse applied to the sync pin will synchronize the LM2586 to an external oscillator (see *Figures 40, 41*).

Use of this feature enables the LM2586 to be synchronized to an external oscillator, such as a system clock. This operation allows multiple power supplies to operate at the same frequency, thus eliminating frequency-related noise problems.

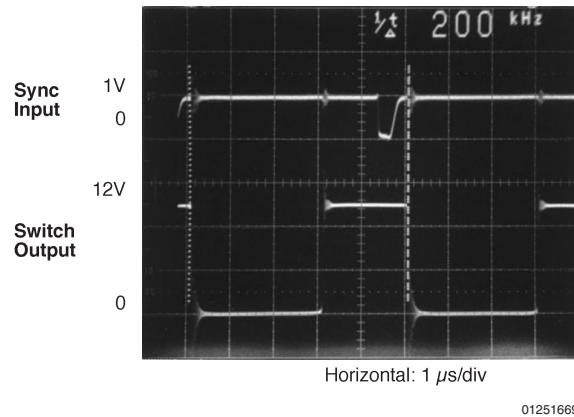

FIGURE 41. Waveforms of a Synchronized 12V Boost Regulator

The scope photo in *Figure 41* shows a LM2586 12V Boost Regulator synchronized to a 200 kHz signal. There is a 700 ns delay between the falling edge of the sync signal and the turning on of the switch.

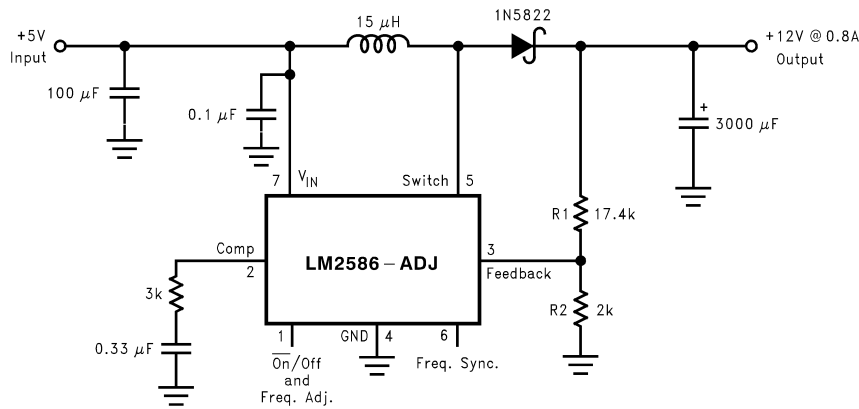

FIGURE 42. Boost Regulator

### PROGRAMMING OUTPUT VOLTAGE (SELECTING R1 AND R2)

Referring to the adjustable regulator in *Figure 42*, the output voltage is programmed by the resistors R1 and R2 by the following formula:

$$V_{OUT} = V_{REF} (1 + R1/R2) \quad \text{where } V_{REF} = 1.23V$$

Resistors R1 and R2 divide the output voltage down so that it can be compared with the 1.23V internal reference. With R2 between 1k and 5k, R1 is:

$$R1 = R2 (V_{OUT}/V_{REF} - 1) \quad \text{where } V_{REF} = 1.23V$$

For best temperature coefficient and stability with time, use 1% metal film resistors.

### SHORT CIRCUIT CONDITION

Due to the inherent nature of boost regulators, when the output is shorted (see *Figure 42*), current flows directly from the input, through the inductor and the diode, to the output, bypassing the switch. The current limit of the switch *does not* limit the output current for the entire circuit. To protect the load and prevent damage to the switch, the current must be externally limited, either by the input supply or at the output

## Application Hints (Continued)

with an external current limit circuit. The external limit should be set to the maximum switch current of the device, which is 3A.

In a flyback regulator application (Figure 43), using the standard transformers, the LM2586 will survive a short circuit to the main output. When the output voltage drops to 80% of its nominal value, the frequency will drop to 25 kHz. With a lower frequency, off times are larger. With the longer off times, the transformer can release all of its stored energy before the switch turns back on. Hence, the switch turns on initially with zero current at its collector. In this condition, the switch current limit will limit the peak current, saving the device.

## FLYBACK REGULATOR INPUT CAPACITORS

A flyback regulator draws discontinuous pulses of current from the input supply. Therefore, there are two input capacitors needed in a flyback regulator—one for energy storage and one for filtering (see Figure 43). Both are required due to the inherent operation of a flyback regulator. To keep a stable or constant voltage supply to the LM2586, a storage capacitor ( $\geq 100 \mu\text{F}$ ) is required. If the input source is a rectified DC supply and/or the application has a wide temperature range, the required rms current rating of the capacitor might be very large. This means a larger value of capacitance or a higher voltage rating will be needed for the input capacitor. The storage capacitor will also attenuate noise which may interfere with other circuits connected to the same input supply voltage.

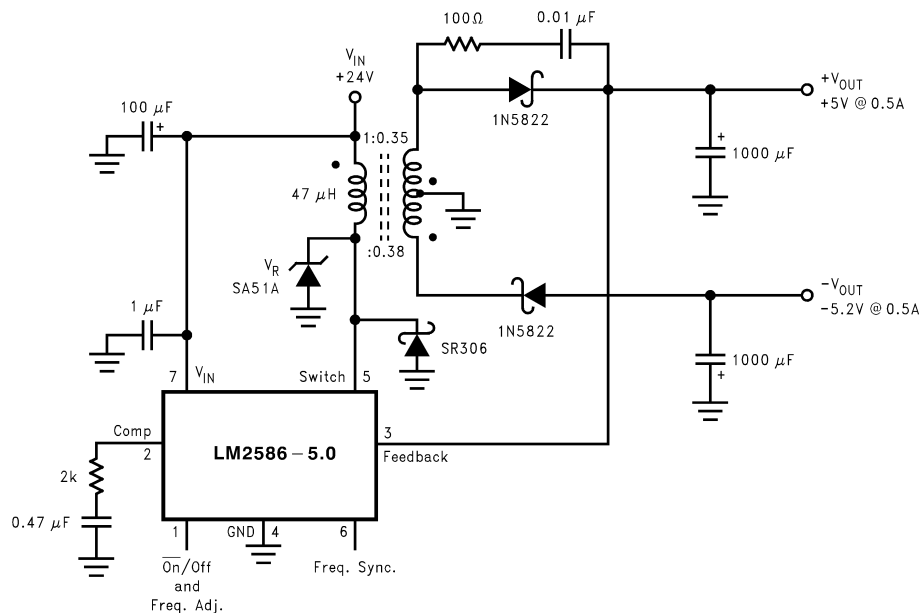

FIGURE 43. Flyback Regulator

In addition, a small bypass capacitor is required due to the noise generated by the input current pulses. To eliminate the noise, insert a  $1.0 \mu\text{F}$  ceramic capacitor between  $V_{IN}$  and ground as close as possible to the device.

### SWITCH VOLTAGE LIMITS

In a flyback regulator, the maximum steady-state voltage appearing at the switch, when it is off, is set by the transformer turns ratio,  $N$ , the output voltage,  $V_{OUT}$ , and the maximum input voltage,  $V_{IN}(\text{Max})$ :

$$V_{SW(\text{OFF})} = V_{IN}(\text{Max}) + (V_{OUT} + V_F)/N$$

where  $V_F$  is the forward biased voltage of the output diode, and is typically  $0.5\text{V}$  for Schottky diodes and  $0.8\text{V}$  for ultra-fast recovery diodes. In certain circuits, there exists a voltage spike,  $V_{LL}$ , superimposed on top of the steady-state voltage (see Figure 5, waveform A). Usually, this voltage spike is caused by the transformer leakage inductance and/or the output rectifier recovery time. To “clamp” the voltage at the switch from exceeding its maximum value, a transient suppressor in series with a diode is inserted across the transformer primary (as shown in the circuit in Figure 4 and other flyback regulator circuits throughout the

datasheet). The schematic in Figure 43 shows another method of clamping the switch voltage. A single voltage transient suppressor (the SA51A) is inserted at the switch pin. This method clamps the total voltage across the switch, not just the voltage across the primary.

If poor circuit layout techniques are used (see the “Circuit Layout Guideline” section), negative voltage transients may appear on the Switch pin (pin 5). Applying a negative voltage (with respect to the IC’s ground) to any monolithic IC pin causes erratic and unpredictable operation of that IC. This holds true for the LM2586 IC as well. When used in a flyback regulator, the voltage at the Switch pin (pin 5) can go negative when the switch turns on. The “ringing” voltage at the switch pin is caused by the output diode capacitance and the transformer leakage inductance forming a resonant circuit at the secondary(ies). The resonant circuit generates the “ringing” voltage, which gets reflected back through the transformer to the switch pin. There are two common methods to avoid this problem. One is to add an RC snubber around the output rectifier(s), as in Figure 43. The values of the resistor and the capacitor must be chosen so that the voltage at the Switch pin does not drop below  $-0.4\text{V}$ . The resistor may

## Application Hints (Continued)

range in value between 10Ω and 1 kΩ, and the capacitor will vary from 0.001 μF to 0.1 μF. Adding a snubber will (slightly) reduce the efficiency of the overall circuit.

The other method to reduce or eliminate the “ringing” is to insert a Schottky diode clamp between pins 5 and 4 (ground), also shown in *Figure 43*. This prevents the voltage at pin 5 from dropping below -0.4V. The reverse voltage rating of the diode must be greater than the switch off voltage.

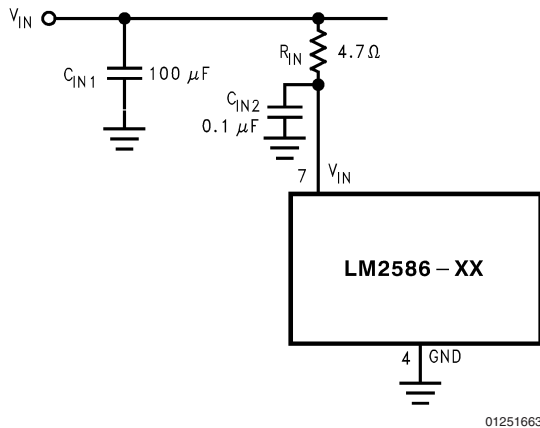

FIGURE 44. Input Line Filter

### OUTPUT VOLTAGE LIMITATIONS

The maximum output voltage of a boost regulator is the maximum switch voltage minus a diode drop. In a flyback regulator, the maximum output voltage is determined by the turns ratio,  $N$ , and the duty cycle,  $D$ , by the equation:

$$V_{OUT} \approx N \times V_{IN} \times D / (1 - D)$$

The duty cycle of a flyback regulator is determined by the following equation:

$$D = \frac{V_{OUT} + V_F}{N(V_{IN} - V_{SAT}) + V_{OUT} + V_F} \approx \frac{V_{OUT}}{N(V_{IN}) + V_{OUT}}$$

Theoretically, the maximum output voltage can be as large as desired—just keep increasing the turns ratio of the transformer. However, there exists some physical limitations that prevent the turns ratio, and thus the output voltage, from increasing to infinity. The physical limitations are capacitances and inductances in the LM2586 switch, the output diode(s), and the transformer—such as reverse recovery time of the output diode (mentioned above).

### NOISY INPUT LINE CONDITION

A small, low-pass RC filter should be used at the input pin of the LM2586 if the input voltage has an unusually large amount of transient noise, such as with an input switch that bounces. The circuit in *Figure 44* demonstrates the layout of the filter, with the capacitor placed from the input pin to ground and the resistor placed between the input supply and the input pin. Note that the values of  $R_{IN}$  and  $C_{IN}$  shown in the schematic are good enough for most applications, but some readjusting might be required for a particular application. If efficiency is a major concern, replace the resistor with a small inductor (say 10 μH and rated at 200 mA).

### STABILITY

All current-mode controlled regulators can suffer from an instability, known as subharmonic oscillation, if they operate with a duty cycle above 50%. To eliminate subharmonic oscillations, a minimum value of inductance is required to ensure stability for all boost and flyback regulators. The minimum inductance is given by:

$$L(\text{Min}) = \frac{2.92 [(V_{IN}(\text{Min}) - V_{SAT}) \cdot (2D(\text{Max}) - 1)]}{1 - D(\text{Max})} (\mu\text{H})$$

where  $V_{SAT}$  is the switch saturation voltage and can be found in the Characteristic Curves.

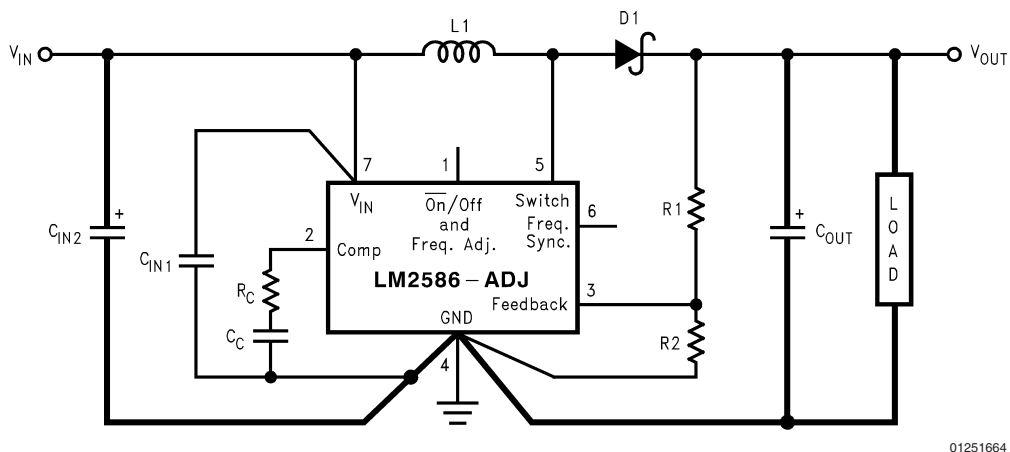

FIGURE 45. Circuit Board Layout

### CIRCUIT LAYOUT GUIDELINES

As in any switching regulator, layout is very important. Rapidly switching currents associated with wiring inductance generate voltage transients which can cause problems. For

minimal inductance and ground loops, keep the length of the leads and traces as short as possible. Use single point grounding or ground plane construction for best results. Separate the signal grounds from the power grounds (as

## Application Hints (Continued)

indicated in *Figure 45*). When using the Adjustable version, physically locate the programming resistors as near the regulator IC as possible, to keep the sensitive feedback wiring short.

### HEAT SINK/THERMAL CONSIDERATIONS

In many cases, a heat sink is not required to keep the LM2586 junction temperature within the allowed operating temperature range. For each application, to determine whether or not a heat sink will be required, the following must be identified:

- 1) Maximum ambient temperature (in the application).
- 2) Maximum regulator power dissipation (in the application).
- 3) Maximum allowed junction temperature (125°C for the LM2586). For a safe, conservative design, a temperature approximately 15°C cooler than the maximum junction temperature should be selected (110°C).
- 4) LM2586 package thermal resistances  $\theta_{JA}$  and  $\theta_{JC}$  (given in the Electrical Characteristics).

Total power dissipated ( $P_D$ ) by the LM2586 can be estimated as follows:

Boost:

$$P_D = 0.15\Omega \cdot \left( \frac{I_{LOAD}}{1-D} \right)^2 \cdot D + \frac{I_{LOAD}}{50 \cdot (1-D)} \cdot D \cdot V_{IN}$$

Flyback:

$$P_D = 0.15\Omega \cdot \left( \frac{N \cdot \Sigma I_{LOAD}}{1-D} \right)^2 \cdot D + \frac{N \cdot \Sigma I_{LOAD}}{50 \cdot (1-D)} \cdot D \cdot V_{IN}$$

$V_{IN}$  is the minimum input voltage,  $V_{OUT}$  is the output voltage,  $N$  is the transformer turns ratio,  $D$  is the duty cycle, and  $I_{LOAD}$  is the maximum load current (and  $\Sigma I_{LOAD}$  is the sum of the maximum load currents for multiple-output flyback regulators). The duty cycle is given by:

Boost:

$$D = \frac{V_{OUT} + V_F - V_{IN}}{V_{OUT} + V_F - V_{SAT}} \approx \frac{V_{OUT} - V_{IN}}{V_{OUT}}$$

Flyback:

$$D = \frac{V_{OUT} + V_F}{N(V_{IN} - V_{SAT}) + V_{OUT} + V_F} \approx \frac{V_{OUT}}{N(V_{IN}) + V_{OUT}}$$

where  $V_F$  is the forward biased voltage of the diode and is typically 0.5V for Schottky diodes and 0.8V for fast recovery diodes.  $V_{SAT}$  is the switch saturation voltage and can be found in the Characteristic Curves.

When no heat sink is used, the junction temperature rise is:

$$\Delta T_J = P_D \cdot \theta_{JA}$$

Adding the junction temperature rise to the maximum ambient temperature gives the actual operating junction temperature:

$$T_J = \Delta T_J + T_A$$

If the operating junction temperature exceeds the maximum junction temperature in item 3 above, then a heat sink is required. When using a heat sink, the junction temperature rise can be determined by the following:

$$\Delta T_J = P_D \cdot (\theta_{JC} + \theta_{Interface} + \theta_{Heat\ Sink})$$

Again, the operating junction temperature will be:

$$T_J = \Delta T_J + T_A$$

As before, if the maximum junction temperature is exceeded, a larger heat sink is required (one that has a lower thermal resistance).

Included in the **Switchers Made Simple**® design software is a more precise (non-linear) thermal model that can be used to determine junction temperature with different input-output parameters or different component values. It can also calculate the heat sink thermal resistance required to maintain the regulator junction temperature below the maximum operating temperature.

To further simplify the flyback regulator design procedure, National Semiconductor is making available computer design software to be used with the Simple Switcher® line of switching regulators. **Switchers Made Simple** is available on a 3½" diskette for IBM compatible computers from a National Semiconductor sales office in your area or the National Semiconductor Customer Response Center (1-800-272-9959).

**Physical Dimensions** inches (millimeters) unless otherwise noted

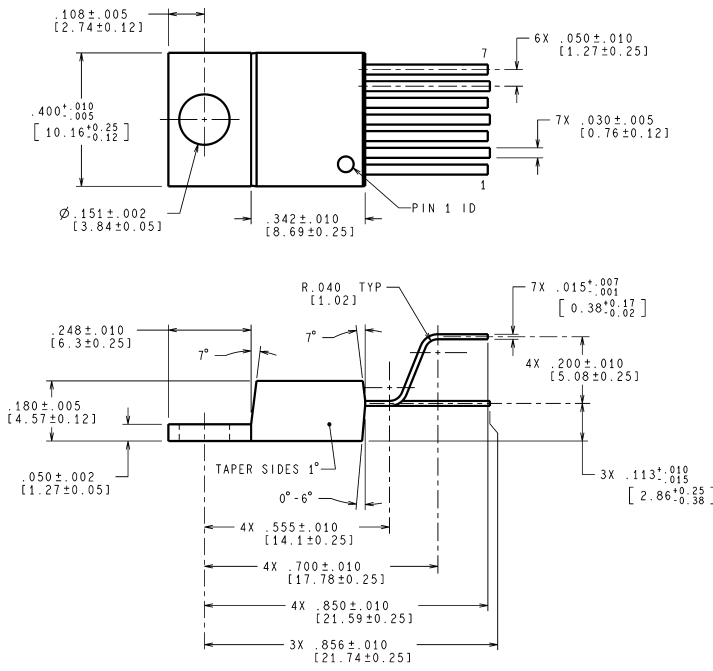

CONTROLLING DIMENSIONS IS INCH  
VALUES IN [ ] ARE MILLIMETERS

TA07B (Rev E)

**Order Number LM2586T-3.3, LM2586T-5.0,  
LM2586T-12 or LM2586T-ADJ  
NS Package Number TA07B**

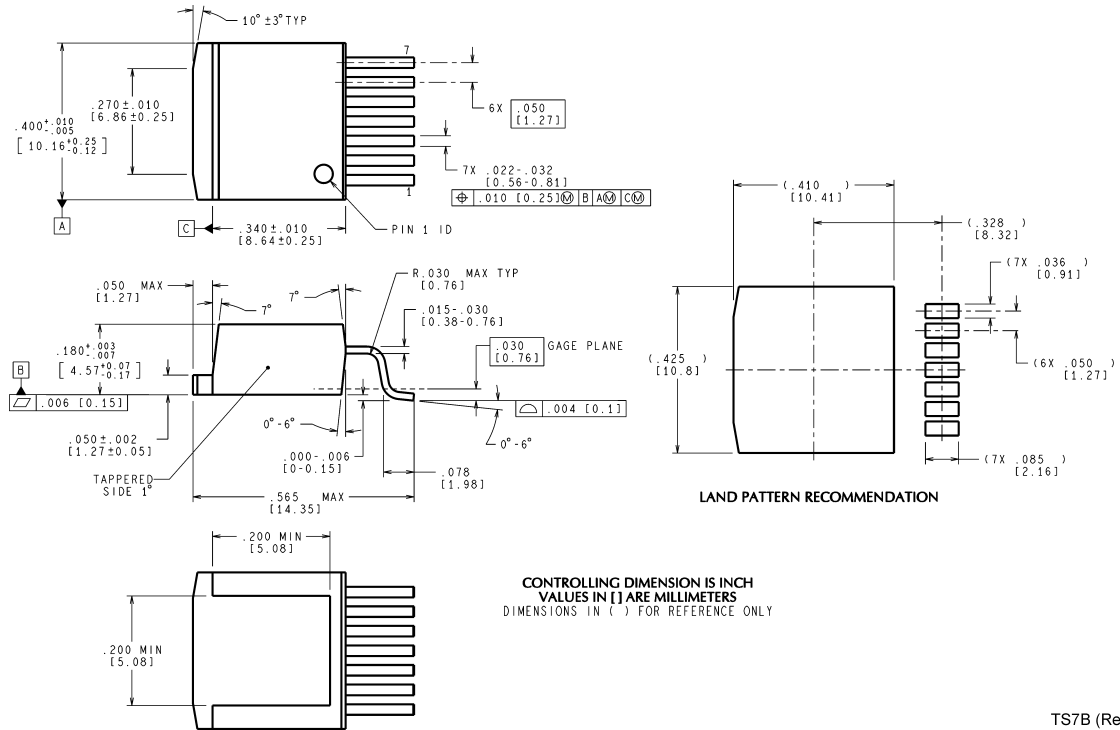

TS7B (Rev E)

**Order Number LM2586S-3.3, LM2586S-5.0,  
LM2586S-12 or LM2586S-ADJ  
Tape and Reel Order Number LM2586SX-3.3,  
LM2586SX-5.0, LM2586SX-12 or LM2586SX-ADJ  
NS Package Number TS7B**

## Notes

National does not assume any responsibility for use of any circuitry described, no circuit patent licenses are implied and National reserves the right at any time without notice to change said circuitry and specifications.

For the most current product information visit us at [www.national.com](http://www.national.com).

### LIFE SUPPORT POLICY

NATIONAL'S PRODUCTS ARE NOT AUTHORIZED FOR USE AS CRITICAL COMPONENTS IN LIFE SUPPORT DEVICES OR SYSTEMS WITHOUT THE EXPRESS WRITTEN APPROVAL OF THE PRESIDENT AND GENERAL COUNSEL OF NATIONAL SEMICONDUCTOR CORPORATION. As used herein:

1. Life support devices or systems are devices or systems which, (a) are intended for surgical implant into the body, or (b) support or sustain life, and whose failure to perform when properly used in accordance with instructions for use provided in the labeling, can be reasonably expected to result in a significant injury to the user.
2. A critical component is any component of a life support device or system whose failure to perform can be reasonably expected to cause the failure of the life support device or system, or to affect its safety or effectiveness.

### BANNED SUBSTANCE COMPLIANCE

National Semiconductor manufactures products and uses packing materials that meet the provisions of the Customer Products Stewardship Specification (CSP-9-111C2) and the Banned Substances and Materials of Interest Specification (CSP-9-111S2) and contain no "Banned Substances" as defined in CSP-9-111S2.

Leadfree products are RoHS compliant.



**National Semiconductor**  
**Americas Customer**  
**Support Center**  
Email: [new.feedback@nsc.com](mailto:new.feedback@nsc.com)  
Tel: 1-800-272-9959

[www.national.com](http://www.national.com)

**National Semiconductor**  
**Europe Customer Support Center**  
Fax: +49 (0) 180-530 85 86  
Email: [europa.support@nsc.com](mailto:europa.support@nsc.com)  
Deutsch Tel: +49 (0) 69 9508 6208  
English Tel: +44 (0) 870 24 0 2171  
Français Tel: +33 (0) 1 41 91 8790

**National Semiconductor**  
**Asia Pacific Customer**  
**Support Center**  
Email: [ap.support@nsc.com](mailto:ap.support@nsc.com)

**National Semiconductor**  
**Japan Customer Support Center**  
Fax: 81-3-5639-7507  
Email: [jpn.feedback@nsc.com](mailto:jpn.feedback@nsc.com)  
Tel: 81-3-5639-7560



## IMPORTANT NOTICE

Texas Instruments Incorporated and its subsidiaries (TI) reserve the right to make corrections, modifications, enhancements, improvements, and other changes to its products and services at any time and to discontinue any product or service without notice. Customers should obtain the latest relevant information before placing orders and should verify that such information is current and complete. All products are sold subject to TI's terms and conditions of sale supplied at the time of order acknowledgment.

TI warrants performance of its hardware products to the specifications applicable at the time of sale in accordance with TI's standard warranty. Testing and other quality control techniques are used to the extent TI deems necessary to support this warranty. Except where mandated by government requirements, testing of all parameters of each product is not necessarily performed.

TI assumes no liability for applications assistance or customer product design. Customers are responsible for their products and applications using TI components. To minimize the risks associated with customer products and applications, customers should provide adequate design and operating safeguards.

TI does not warrant or represent that any license, either express or implied, is granted under any TI patent right, copyright, mask work right, or other TI intellectual property right relating to any combination, machine, or process in which TI products or services are used. Information published by TI regarding third-party products or services does not constitute a license from TI to use such products or services or a warranty or endorsement thereof. Use of such information may require a license from a third party under the patents or other intellectual property of the third party, or a license from TI under the patents or other intellectual property of TI.

Reproduction of TI information in TI data books or data sheets is permissible only if reproduction is without alteration and is accompanied by all associated warranties, conditions, limitations, and notices. Reproduction of this information with alteration is an unfair and deceptive business practice. TI is not responsible or liable for such altered documentation. Information of third parties may be subject to additional restrictions.

Resale of TI products or services with statements different from or beyond the parameters stated by TI for that product or service voids all express and any implied warranties for the associated TI product or service and is an unfair and deceptive business practice. TI is not responsible or liable for any such statements.

TI products are not authorized for use in safety-critical applications (such as life support) where a failure of the TI product would reasonably be expected to cause severe personal injury or death, unless officers of the parties have executed an agreement specifically governing such use. Buyers represent that they have all necessary expertise in the safety and regulatory ramifications of their applications, and acknowledge and agree that they are solely responsible for all legal, regulatory and safety-related requirements concerning their products and any use of TI products in such safety-critical applications, notwithstanding any applications-related information or support that may be provided by TI. Further, Buyers must fully indemnify TI and its representatives against any damages arising out of the use of TI products in such safety-critical applications.

TI products are neither designed nor intended for use in military/aerospace applications or environments unless the TI products are specifically designated by TI as military-grade or "enhanced plastic." Only products designated by TI as military-grade meet military specifications. Buyers acknowledge and agree that any such use of TI products which TI has not designated as military-grade is solely at the Buyer's risk, and that they are solely responsible for compliance with all legal and regulatory requirements in connection with such use.

TI products are neither designed nor intended for use in automotive applications or environments unless the specific TI products are designated by TI as compliant with ISO/TS 16949 requirements. Buyers acknowledge and agree that, if they use any non-designated products in automotive applications, TI will not be responsible for any failure to meet such requirements.

Following are URLs where you can obtain information on other Texas Instruments products and application solutions:

### Products

Audio	<a href="http://www.ti.com/audio">www.ti.com/audio</a>
Amplifiers	<a href="http://amplifier.ti.com">amplifier.ti.com</a>
Data Converters	<a href="http://dataconverter.ti.com">dataconverter.ti.com</a>
DLP® Products	<a href="http://www.dlp.com">www.dlp.com</a>
DSP	<a href="http://dsp.ti.com">dsp.ti.com</a>
Clocks and Timers	<a href="http://www.ti.com/clocks">www.ti.com/clocks</a>
Interface	<a href="http://interface.ti.com">interface.ti.com</a>
Logic	<a href="http://logic.ti.com">logic.ti.com</a>
Power Mgmt	<a href="http://power.ti.com">power.ti.com</a>
Microcontrollers	<a href="http://microcontroller.ti.com">microcontroller.ti.com</a>
RFID	<a href="http://www.ti-rfid.com">www.ti-rfid.com</a>
OMAP Mobile Processors	<a href="http://www.ti.com/omap">www.ti.com/omap</a>
Wireless Connectivity	<a href="http://www.ti.com/wirelessconnectivity">www.ti.com/wirelessconnectivity</a>

### Applications

Communications and Telecom	<a href="http://www.ti.com/communications">www.ti.com/communications</a>
Computers and Peripherals	<a href="http://www.ti.com/computers">www.ti.com/computers</a>
Consumer Electronics	<a href="http://www.ti.com/consumer-apps">www.ti.com/consumer-apps</a>
Energy and Lighting	<a href="http://www.ti.com/energy">www.ti.com/energy</a>
Industrial	<a href="http://www.ti.com/industrial">www.ti.com/industrial</a>
Medical	<a href="http://www.ti.com/medical">www.ti.com/medical</a>
Security	<a href="http://www.ti.com/security">www.ti.com/security</a>
Space, Avionics and Defense	<a href="http://www.ti.com/space-avionics-defense">www.ti.com/space-avionics-defense</a>
Transportation and Automotive	<a href="http://www.ti.com/automotive">www.ti.com/automotive</a>
Video and Imaging	<a href="http://www.ti.com/video">www.ti.com/video</a>

TI E2E Community Home Page

[e2e.ti.com](http://e2e.ti.com)

Mailing Address: Texas Instruments, Post Office Box 655303, Dallas, Texas 75265  
Copyright © 2011, Texas Instruments Incorporated