



CIRCUIT-BREAKER, SIZE S00, FOR MOTOR PROTECTION, CLASS 10, A REL.9...12 A, N REL.156 A, 1NO + 1NC TRANSVERSE, SCREW CONN., STANDARD BREAKING CAPAC.

product brand name		SIRIUS
Product designation		circuit breaker
Design of the product		for motor protection

General technical data:

Active power loss total typical	W	7
Shock resistance		25g / 11 ms
Surge voltage resistance Rated value	V	6 000
Mechanical service life (switching cycles)		
• of the main contacts typical		100 000
Protection class IP		
• on the front		IP20
Equipment marking		
• acc. to DIN EN 61346-2		Q

Main circuit:

Number of poles for main current circuit		3
Adjustable response value current of the current-dependent overload release	A	9 ... 12
Operating voltage		
• Rated value	V	690
• at AC-3 Rated value maximum	V	690
Operating current		
• at AC-3		
— at 400 V Rated value	A	12
Operating power		
• at AC-3		

— at 400 V Rated value	kW	5.5
Operating frequency		
• at AC-3 maximum	1/h	15

Auxiliary circuit:

Number of CO contacts		
• for auxiliary contacts		0
Product expansion Auxiliary switch		Yes
Design of the auxiliary switch		transverse
Operating current of the auxiliary contacts at AC-15		
• at 24 V	A	2
• at 230 V	A	0.5
Operating current of the auxiliary contacts at DC-13		
• at 24 V	A	1
• at 60 V	A	0.15

Protective and monitoring functions:

Trip class		CLASS 10
Maximum short-circuit current breaking capacity (Icu)		
• with AC at 240 V Rated value	kA	100
• with AC at 400 V Rated value	kA	50
• with AC at 500 V Rated value	kA	3
• with AC at 690 V Rated value	kA	2

Short-circuit:

Design of the overcurrent release and short-circuit release		thermomagnetic
--	--	----------------

Installation/ mounting/ dimensions:

mounting position		any
Mounting type		screw and snap-on mounting onto 35 mm standard mounting rail according to DIN EN 50022
Height	mm	90
Width	mm	45
Depth	mm	81
Required spacing		
• with side-by-side mounting		
— Backwards	mm	0
— at the side	mm	0

Connections/ Terminals:

Type of electrical connection		
• for main current circuit		screw-type terminals
• for auxiliary and control current circuit		screw-type terminals
Arrangement of electrical connectors for main current circuit		front side

Product function		No
<ul style="list-style-type: none"> • removable terminal for auxiliary and control circuit 		
Type of connectable conductor cross-section		
<ul style="list-style-type: none"> • for main contacts <ul style="list-style-type: none"> — solid — stranded — finely stranded with core end processing • for AWG conductors for main contacts • for auxiliary contacts <ul style="list-style-type: none"> — solid — finely stranded with core end processing • for AWG conductors for auxiliary contacts 		2x (0.5 ... 1.5 mm ²), 2x (0.75 ... 2.5 mm ²) 2x (0.5 ... 1.5 mm ²), 2x (0.75 ... 2.5 mm ²) 2x (0.5 ... 1.5 mm ²), 2x (0.75 ... 2.5 mm ²) 2x (18 ... 14) 2x (0.5 ... 1.5 mm ²), 2x (0.75 ... 2.5 mm ²) 2x (0.5 ... 1.5 mm ²), 2x (0.75 ... 2.5 mm ²) 2x (18 ... 14)

Safety related data:

Protection against electrical shock		finger-safe
--	--	-------------

Mechanical data:

Size of the circuit-breaker		S00
------------------------------------	--	-----

Ambient conditions:

Installation altitude at height above sea level maximum	m	2 000
Ambient temperature		
<ul style="list-style-type: none"> • during operation • during storage • during transport 	°C °C °C	-20 ... +60 -50 ... +80 -50 ... +80

Certificates/ approvals:

General Product Approval	Test Certificates	Shipping Approval
--------------------------	-------------------	-------------------



[Special Test Certificate](#)



Shipping Approval



other

[Declaration of Conformity](#)

[other](#)

[Environmental Confirmations](#)

[Confirmation](#)



Further information

Information- and Downloadcenter (Catalogs, Brochures,...)
<http://www.siemens.com/industrial-controls/catalogs>

Industry Mall (Online ordering system)
<http://www.siemens.com/industrymall>

Cax online generator
<http://support.automation.siemens.com/WW/CAXorder/default.aspx?lang=en&mlfb=3RV10111KA15>

Service&Support (Manuals, Certificates, Characteristics, FAQs,...)
<http://support.automation.siemens.com/WW/view/en/3RV10111KA15/all>

Image database (product images, 2D dimension drawings, 3D models, device circuit diagrams, EPLAN macros, ...)
http://www.automation.siemens.com/bilddb/cax_de.aspx?mlfb=3RV10111KA15&lang=en

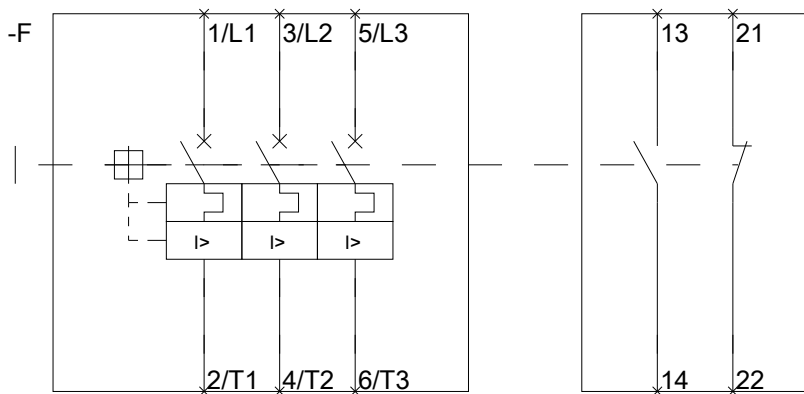
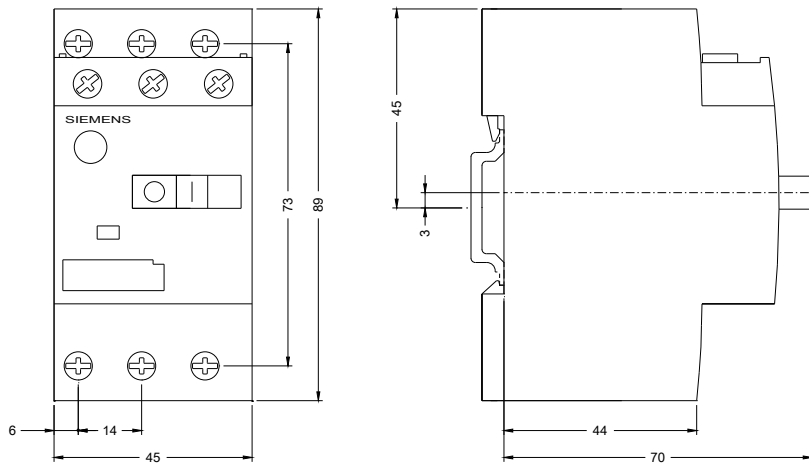

last modified:

11.03.2015