

TYPE No. : CP2S-2E□□

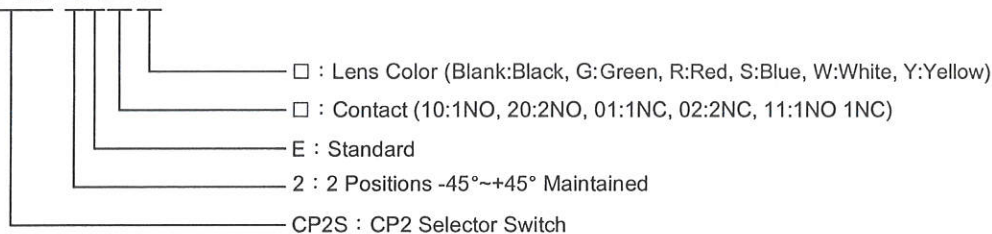

ORDER No. : CP2S-2E□□

Contact Block Mounting Position

| Configuration | Contact | Position | Operator Position | | Contact Part |
|---------------|---------|----------|-------------------|-------|---------------|
| | | | Left | Right | |
| 10 | ① | NO | | ● | SCP2-E10P |
| | ② | — | | | Empty Contact |
| 20 | ① | NO | | ● | SCP2-E10P |
| | ② | NO | | ● | SCP2-E10P |
| 01 | ① | NC | ● | | SCP2-E01P |
| | ② | — | | | Empty Contact |
| 02 | ① | NC | ● | | SCP2-E01P |
| | ② | NC | ● | | SCP2-E01P |
| 11 | ① | NO | | ● | SCP2-E10P |
| | ② | NC | ● | | SCP2-E01P |

Contact Ratings

| Rated Insulation Voltage (Ui) | | 400V | | | | |
|-------------------------------|--------------------------------|------|------|-------|-------|-------|
| Rated Thermal Current (Ith) | | 8A | | | | |
| Rate Operational Voltage (Ue) | | 12V | 30V | 120V | 240V | 380V |
| AC 50/60HZ | Resistive Load (AC-12) (Ie) | 8A | 8A | 8A | 6A | 3.8A |
| | Inductive Load (AC-15) (Ie) | 8A | 8A | 6A | 3A | 1.9A |
| Rate Operational Voltage (Ue) | | 12V | 30V | 125V | 250V | 400V |
| DC | Resistive Load (DC-12) (Ie) | 2.5A | 2.5A | 1.1A | 0.55A | 0.3A |
| | Inductive Load (DC-13) (Ie) | 2.5A | 2.3A | 0.55A | 0.27A | 0.15A |

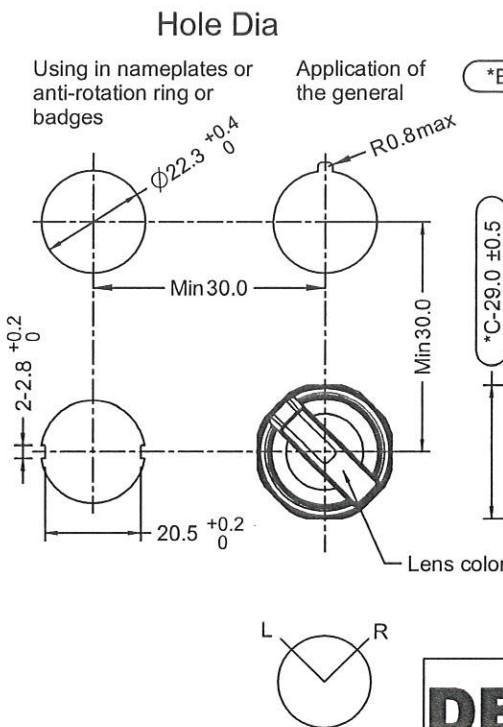

Product Specifications

Mechanical life : >500,000 operations
 Electrical life : >100,000 operations
 Electrical durability : 1,000,000 cycles AC-15, 230V/1.6A
 1,000,000 cycles DC-13, 24V/0.6A
 Rate insulation voltage : 400V
 Rated thermal current : 8A
 Contact resistance : 100mΩ max. (at 1A 6-8V DC)
 Insulation resistance : 100MΩ min. (at 500V DC)
 Dielectric strength : 2000V AC 50/60 HZ for 1 min
 Degree of protection : IP66, Type 4X Indoor use only & Type 13
 IP30 (under panel)
 Storage temperature : -40°C to +85°C
 Operating temperature : -25°C to +70°C
 Operating humidity : 45% to 85% RH
 Approved standards : UL508(CSA C22.2 No.14), UL1059
 A300 Q300, IEC 60947-5-1, GB/T 14048.5
 Hazardous substances : Corresponding RoSH and REACH
 Wire diameter : 16~26 AWG, 0.2~1.5mm²
 Stripping length : 8mm

RoHS
Compliant



Pushbutton Switches

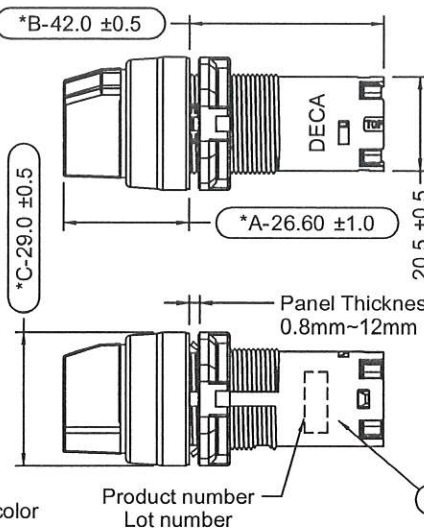

Component

| Item | Name | Material | Number |
|------|---------------|----------|--------|
| 1 | CP2S-2E | — | 1 |
| 2 | Partition | PA66 | 1 |
| 3 | Contact ① | — | 1 |
| 4 | Contact ② | — | 1 |
| | Empty Contact | PA66+G20 | |



B

REV.

DECA® SwitchLab Inc.

| DESIGN | CHECK | APPROVE |
|------------|-------------|-------------|
| TIM | [Signature] | [Signature] |
| DATE | DATE | DATE |
| 2019/04/23 | 2019/04/23 | 2019/04/23 |

| PART NAME | UNIT | SCALE |
|-----------------------|-------|---------|
| CP2 Selector Switches | MM | 0.6 : 1 |
| DRAWING NO. | SHEET | |
| CP2S-2E□□ | 1 / 1 | |