

MATERIAL

Cast aluminium or die-cast zinc-alloy, epoxy resin coating, RAL 9005 black colour, matte finish.

STANDARD EXECUTIONS

Revolving handle in polyamide based (PA) technopolymer, black colour, matte finish.

- **GN 471-B**: cast aluminium, H7 reamed hole.
- **GN 471-V**: cast aluminium, H11 square hole.
- **GN 471.1-B**: zinc-alloy, H7 reamed hole.
- **GN 471.1-V**: zinc-alloy, H11 square hole.

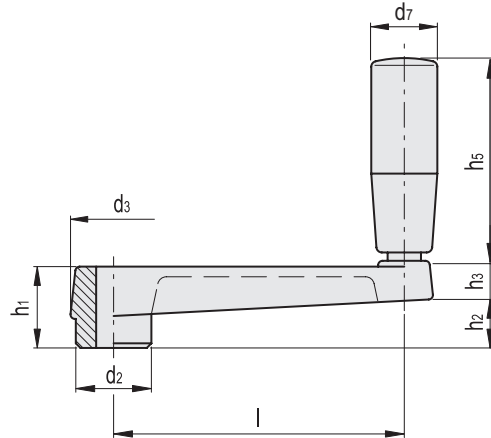
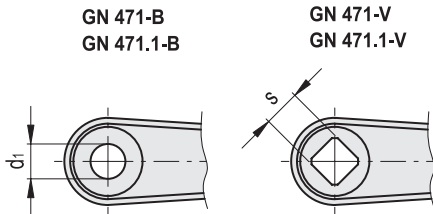

GN 471

Code	Description	l	d1 H7	sH11	d2	d3	h1	h2	h3	h5	d7	⚖️
GN.22511	GN 471-80-B10	80	10	-	23	26	24	14	14	52.5	21	101
GN.22512	GN 471-80-V10	80	-	10	23	26	24	14	14	52.5	21	98
GN.22521	GN 471-100-B12	100	12	-	27	30	28	17	15	67.5	23	170
GN.22522	GN 471-100-V12	100	-	12	27	30	28	17	15	67.5	23	167
GN.22531	GN 471-125-B14	125	14	-	32	35	34	22	18	82.5	26	255
GN.22532	GN 471-125-V14	125	-	14	32	35	34	22	18	82.5	26	251
GN.22541	GN 471-160-B17	160	17	-	35	39	38	26	18	82.5	26	319
GN.22542	GN 471-160-V17	160	-	17	35	39	38	26	18	82.5	26	313

GN 471.1

Code	Description	l	d1 H7	sH11	d2	d3	h1	h2	h3	h5	d7	⚖️
GN.22501	GN 471.1-64-B10	64	10	-	19	22	20	11	12	42.5	18	100
GN.22502	GN 471.1-64-V10	64	-	10	19	22	20	11	12	42.5	18	97

