

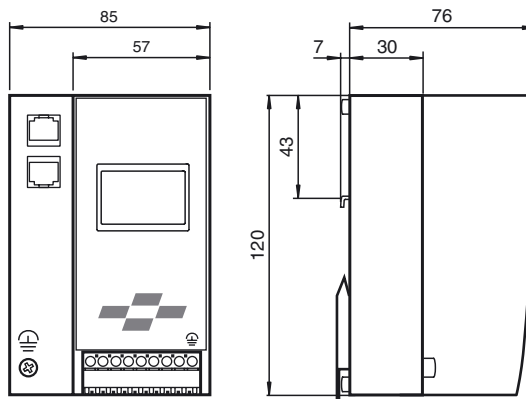

Dimensions

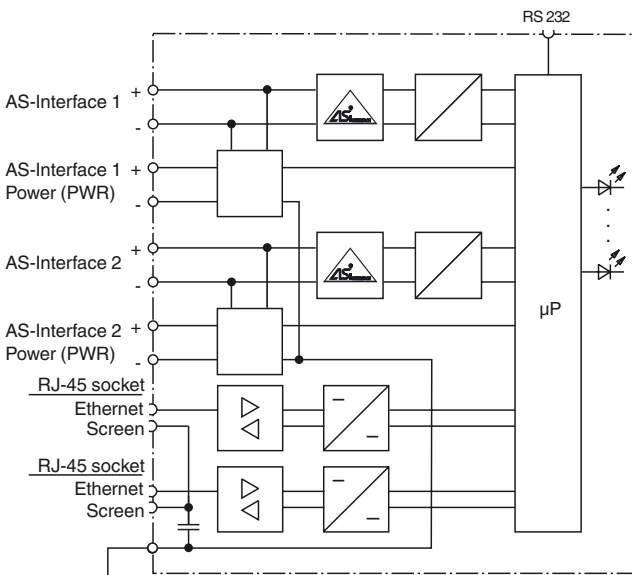

Electrical connection



AS-Interface circuit 1 and 2 are supplied from different power supplies. At the cable for power supply no slaves or repeaters may be attached. At the cable for AS-Interface circuit no power supplies or further masters may be attached.

Model number

VBG-ENX-K20-DMD

EtherNet/IP + Modbus TCP Gateway, double master for 2 AS-Interface networks

Features

- Gateway compliant with AS-Interface specification 3.0
- Connection to Ethernet Modbus TCP/IP
- 2 AS-Interface networks
- Duplicate addressing detection
- Integrated webserver
- Earth fault detection
- AS-Interface noise detection
- Ethernet diagnostic interface
- Integrated switch allows line topology
- DLR technology supports ring topology

Indicating / Operating means

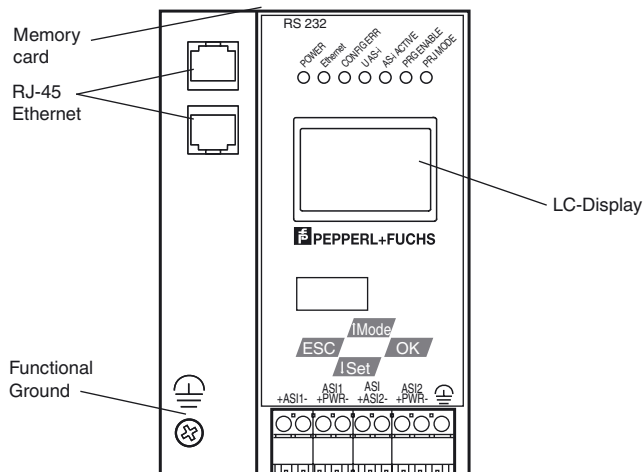

Release date: 2014-03-18 17:27 Date of issue: 2014-03-18 217256_eng.xml

Refer to "General Notes Relating to Pepperl+Fuchs Product Information".

Pepperl+Fuchs Group
www.pepperl-fuchs.com

USA: +1 330 486 0001
fa-info@us.pepperl-fuchs.com

Germany: +49 621 776 4411
fa-info@de.pepperl-fuchs.com

Singapore: +65 6779 9091
fa-info@sg.pepperl-fuchs.com

Technical data**General specifications**

AS-Interface specification	V3.0
PLC-Functionality	activateable
Duplicate address detection	from AS-Interface slaves
Earth fault detection	EFD integrated
EMC monitoring	integrated
Diagnostics function	Extended function via display
UL File Number	E223772

Functional safety related parameters

MTTF _d	100 a at 30 °C
-------------------	----------------

Indicators/operating means

Display	Illuminated graphical LC display for addressing and error messages
LED ETHERNET	ethernet active; LED green
LED AS-i ACTIVE	AS-Interface operation normal; LED green
LED CONFIG ERR	configuration error; LED red
LED PRG ENABLE	autom. programming; LED green
LED POWER	voltage ON; LED green
LED PRJ MODE	projecting mode active; LED yellow
LED U AS-i	AS-Interface voltage; LED green
Button	4

Electrical specifications

Insulation voltage	U _i	≥ 500 V
Rated operating voltage	U _e	from AS-Interface 30 V DC
Rated operating current	I _e	≤ 200 mA from AS-Interface circuit 1 ≤ 70 mA from AS-Interface circuit 2

Interface 1

Interface type	2 x RJ-45
Protocol	EtherNet/IP + MODBUS TCP/IP according to IEEE 802.3 supports device level ring protocol DLR
Transfer rate	10 MBit/s / 100 MBit/s , Automatic baud rate detection

Interface 2

Interface type	RS 232, serial Diagnostic Interface
Transfer rate	19,2 kBit/s

Interface 3

Interface type	Chip card slot
----------------	----------------

Connection

Ethernet	RJ-45
AS-Interface	spring terminals, removable

Ambient conditions

Ambient temperature	0 ... 55 °C (32 ... 131 °F)
Storage temperature	-25 ... 85 °C (-13 ... 185 °F)

Mechanical specifications

Degree of protection	IP20
Mass	500 g
Construction type	Low profile housing , Stainless steel

Compliance with standards and directives

Directive conformity	
EMC Directive 2004/108/EC	EN 61000-6-2:2005, EN 61000-6-4:2007
Standard conformity	
Electromagnetic compatibility	EN 61000-6-2:2005, EN 61000-6-4:2007
AS-Interface	EN 50295:1999
Degree of protection	EN 60529:2000
Shock and impact resistance	EN 61131-2:2004
Standards	EN 61000-6-2:2005, EN 61000-6-4:2007 EN 954-1:1996 (up to Kategorie 4), IEC 61508:2001 and EN 62061:2005 (up to SIL3) EN 13849:2008 (PL e)

Notes

In an AS-Interface network only one device can be operated earth fault detection. If there are many devices in an AS-Interface network, this can lead to the earth fault monitoring response threshold becoming less sensitive.

Function

The VBG-ENX-K20-DMD is an Ethernet/IP + Modbus TCP gateway with 2 AS-Interface masters in accordance with AS-Interface specification 3.0. This means that data can be transferred from 2 parallel AS-Interface branches via one IP address.

The design of the K20 in stainless steel with IP20 is particularly suited for use in switching cabinets for snap on mounting on the 35 mm mounting rail.

The gateway in accordance with the AS-Interface specification V 3.0 is used to connect AS-Interface systems to a higher-level net. It acts as a master for the AS-Interface segment and as a slave for the higher-level net. During cyclic data exchange, the digital data of an AS-Interface segment is transferred. Analog values as well as the complete command set of the new AS-Interface specification are transferred using a command interface.

The address allocation and acceptance of the target configuration can be achieved via the keys. 7 LEDs fitted to the front panel indicate the actual state of the AS-Interface branch.

With the graphical display, the commissioning of the AS-Interface circuits and testing of the connected peripherals can take place completely separately from the commissioning of the higher-level network and the programming. With the 4 switches, all functions can be controlled and visualized on the display.

The device has a card slot for a memory card for the storage of configuration data.

An integrated Switch and 2 RJ-45 sockets allow the design of a line topology without the use of an external Switch.

The device level ring protocol DLR increases the reliability of a ring topology at the device level, thus optimizing the machine running times.

An integrated webserver allows to administrate the device and The AS-interface network without additional hard and/or software via a browser interface.

The redundant power supply guarantees that the double master remains in function and is diagnosticable, when a failure of a power supply unit in one of the two AS-interfaces circles occurs. Also communication with the superior field bus is not disturbed by the failure of a power supply.

PLC Functionality

Optionally the gateway is also available with PLC functionality. Therefore you can order a code key VAZ-CTR additionally.

Accessories**VAZ-SW-ACT32**

Full version of the AS-I Control Tools including connection cable

USB-0,8M-PVC ABG-SUBD9

Interface converter USB/RS 232