

Classical V Belts:

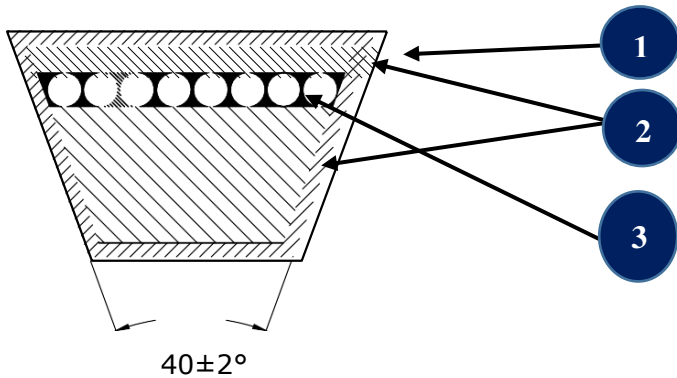
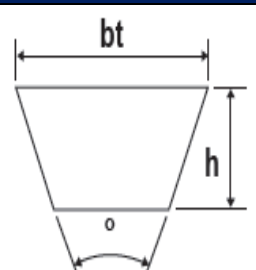

1	Polychloroprene rubber impregnated in poly cotton fabric
2	SBR cushion rubber
3	Polyester tension cords

Classical V belts				
Profile	Top Width ± 0.8mm "bt" top width	Depth ± 0.8mm "h" depth	Angle ±2° "o"	
Z	10	6	40	
A	12.7	8	40	
B	16.5	11	14	
C	21.5	14	40	
D	31.5	19	40	

Belt Standard:	Mass per Unit /length	Length Range
BS3790	Z - 0.000 kg/n	Z - 17-65"
DIN 7753 Pt. 1	A - 0.108 kg/m	A - 490-4610mm
ISO 4184	B - 0.162 kg/m	B - 550-7030mm
	C - 0.299 kg/m	C - 1000-10670mm
	D - 0.608 kg/m	D - 1990-15200mm

Characteristics:
Operating Temps -30/+70°Celsius
Anti-Static & Oil Resistant.
Shelf Life 3 years

MECALINE belts are robust & durable, used widely in all aspects of industry. Conforming to professional standards & super length stability means it is the Engineers preference by choice.