

DO NOT SCALE DRAWING

REVISION

A INITIAL DRAWING 25.01.16

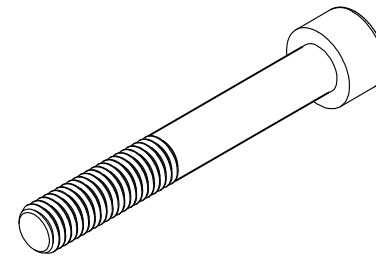
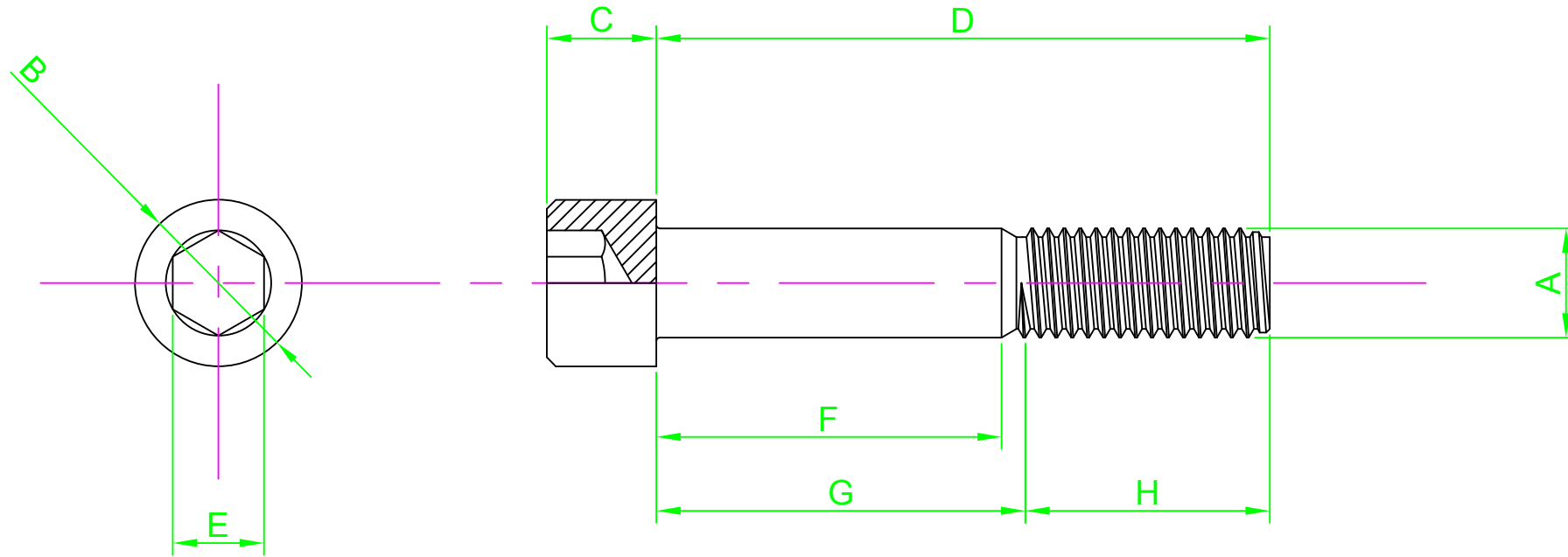

Part Number	ØA	B Max	C Max	D Length	E Nom	F Min	G Max	H Ref
M8 25 SOA2CS S25	M8-1.25	13.27	8.0	25.0	6.0	N/A	3.75	N/A
M8 30 SOA2CS S25				30.0				
M8 40 SOA2CS S25				40.0				
M8 45 SOA2CS S25				45.0				
M10 20 SOA2CS S25	M10-1.50	16.27	10.0	20.0	8.0	N/A	4.5	N/A

NOTES:



UNLESS OTHERWISE SPECIFIED:
DIMENSIONS ARE IN MM (MILLIMETERS).
SURFACE FINISH:
TOLERANCES: DIN 912

MATERIAL:
Stainless Steel A2

TITLE:
Hex Socket Head Cap Screw DIN 912

	NAME	DATE
DRAWN	Darryl Wilson	25.01.16
CHK'D		
APPV'D		

HEAT TREATMENT:
N/A

DESIGN RIGHT. TR FASTENINGS LTD, 2003
UNDER NO CIRCUMSTANCES MUST THIS
DRAWING BE COPIED OR DISCLOSED
WITHOUT FIRST OBTAINING WRITTEN
AUTHORITY.

CUSTOMER PART NUMBER:
N/A

FINISH:
Self Finish

DRAWING NUMBER:
TR32SOA2CSS25

A4

PROJECTION

