

Temperature Sensor Acquisition Board

The Temperature Sensor Demonstration Board measures the temperature from -45°C up to +130 °C using Smartec's temperature sensors and sends the temperature as a standard ASCII string. The kit is based on a Microchip's PIC12F629 microcontroller and uses a RS232 interface (COMx port) to communicate with a standard personal computer. Up to 4 sensors can be connected simultaneously; the software will test all the inputs automatically on power up after which it



will process only the ones with sensors connected. The measurement will start automatically after connecting the board to a serial interface connector and after configuration of the corresponding COM port. The board can be plugged in directly to the computer. Only four lines of the RS232 standard 9-pin connector are used: pin 2 (RD), pin 3 (TD), pin 5 (GND) and pin 7 (RTS). **If an extension cable is used it must have a straight connection.** A LED on the board will indicate a proper connection. The measurement results of different sensors are separated in the output string by a 'SPACE' (\$20). The consecutive measurements are separated by LF, CR (\$0D, \$0A) commands. Each measured value is sent in 5 or 6 bytes. For instance 20.15°C is sent as 2 then 0 then . and 1 and finally 5. In case the temperature is above 100 °C an extra byte is sent '1' and in case the temperature is negative a minus is sent before.

One measurement cycle and calculation takes approximately 500 ms.

If there is only one sensor connected it should be placed on position 1 on the board (connected with pin GP4 of the PIC12F629). If the user does not want to connect a sensor on position 1 it should be connected to Vdd directly or via an additional resistor. Starting the board with pin GP4 floating will result in unstable functioning of the board, however no permanent damage will occur: the proper operation can be restored after the correct hardware configuration of the board. The stability will not be influenced by the position of the other sensors.

Every program capable of receiving standard ASCII strings, for example Hyper Terminal of Windows 95/98/NT, can visualize the results. If the user prefers his own program the board should be powered by putting pin 7 (RTS) in logical 0 (+12V). For logging purposes Smartec has available a special temperature logging program available (on the www in the supportshop 'software')

If the demonstration board has to be used on a computer system that uses 5V for the logical 0 on the serial interface (laptops, notebooks, etc.), it needs to be connected to an external power supply.

The serial port communication has to be configured in the following way:

Baud Rate: 9600 Data bits: 8 Stop bit: 1 Parity check: None Flow control: None

The measurement will start immediately after the board is connected to the serial port and the controlling program is started. At the same time the LED on the board will light up. If this does not occur, please check the serial port connection and configuration.

SMTAS04 4 SENSOR evaluation board

Temperature Sensor Board Schematic

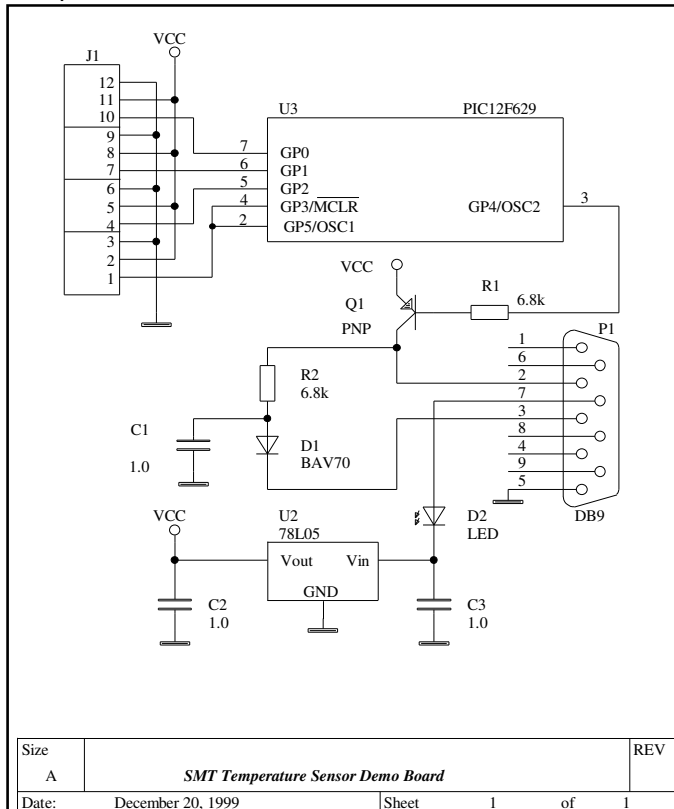

Pinout of sensor connector J1:

- 1 Output sensor 1
- 2 Vcc sensor1
- 3 Gnd sensor 1
- 4 Output sensor 2
- 5 Vcc sensor 2
- 6 Gnd sensor 2
- 7 Output sensor 3
- 8 Vcc sensor 3
- 9 Gnd sensor 3
- 10 Output sensor 4
- 11 Vcc sensor 4
- 12 Gnd sensor 4

Pinout of DB9 connector to PC:

- 2 RD
- 3 TD
- 5 GND
- 7 RTS



SMTAS04 4 SENSOR evaluation board

Measuring the duty cycle

The measurement routine is based on a free running 16-bit timer TMR1. The counting frequency is 1 MHz. The flowchart of the measurement routine is shown on the figure:

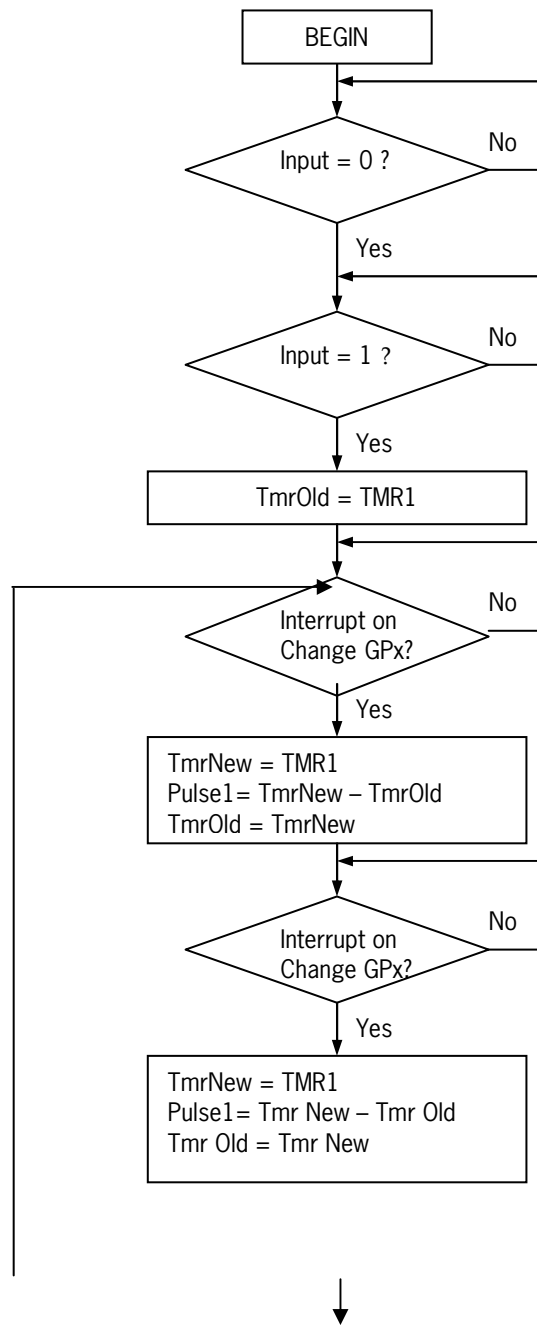

SMTAS04 4 SENSOR evaluation board

The result is calculated according to the formula:

$$\text{D.C.} = \text{Pulse1} / (\text{Pulse0} + \text{Pulse1})$$
$$\text{Temperature} = (\text{D.C.} - 0.3200) / 0.0047$$

This small PC-board is only developed as a demonstrator to show the ease of interfacing temperature sensors to micros. For logging purposes Smartec has available a special temperature logging program available (on the www in the supportshop 'software')

For the specifications of the Smartec temperature sensor please refer to the specification sheet.

USB version.

For ease of operation there is available an USB version of the SMTAS04. The operation is similar to the SMTAS04 with the exception of interfacing to a VCOM virtual COM port by means of a FTDI chip. For more information how to install driver software on PC please go to the support shop of the website for relevant data on USB to RS232.

Ordering information

SMTAS04	Smartec interface board for 4 SMT temperature sensors and a RS232 serial output
SMTAS04USB	Smartec interface board for 4 SMT temperature sensors and an USB output.
SMT1603018	Smartec temperature sensor in TO18 encapsulation (metal can)
SMT1603092	Smartec temperature sensor in TO92 encapsulation (commercial)
SMT16030220	Smartec temperature sensor in TO220 encapsulation
SMT16030SO	Smartec temperature sensor in SOIC8
SMT16030HEMP	Smartec temperature sensor as small hybrid (2.5. x 8 mm)

