

OGE103

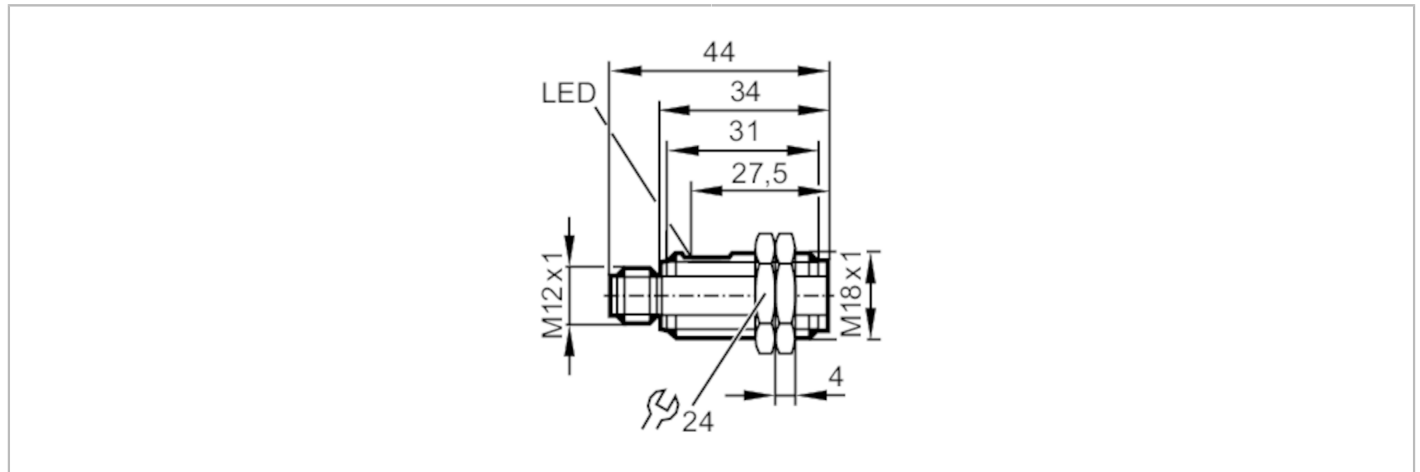

Through-beam sensor receiver

OGE-HNKG/US



Product characteristics	
Type of light	red light
Housing	threaded type
Dimensions [mm]	M18 x 1 / L = 44
Application	
Function principle	Through-beam sensor
Electrical data	
Operating voltage [V]	10...30 DC
Current consumption [mA]	8
Protection class	III
Reverse polarity protection	yes
Type of light	red light
Outputs	
Electrical design	NPN
Output function	light-on mode
Max. voltage drop switching output DC [V]	2.5
Permanent current rating of switching output DC [mA]	200
Switching frequency DC [Hz]	1000
Short-circuit protection	yes
Overload protection	yes
Detection zone	
Transmitter / receiver	receiver
Range [m]	< 8
Range adjustable	no
Operating conditions	
Ambient temperature [°C]	-25...60
Protection	IP 67; (in conjunction with a corresponding connector)

OGE103



Through-beam sensor receiver

OGE-HNKG/US

Tests / approvals		
EMC		EN 60947-5-2
MTTF	[years]	1320
Mechanical data		
Weight	[g]	14.5
Housing		threaded type
Dimensions	[mm]	M18 x 1 / L = 44
Thread designation		M18 x 1
Materials		housing: ABS
Lens material		PMMA
Displays / operating elements		
Display	switching status	1 x LED, yellow
Accessories		
Accessories (supplied)		lock nuts: 2 x
Remarks		
Pack quantity		1 pcs.

Electrical connection

Connector: 1 x M12



Connection

