

Customer Information Sheet

DRAWING No.: S7051-42R

IF IN DOUBT - ASK

©

NOT TO SCALE

THIRD ANGLE PROJECTION

ALL DIMENSIONS IN mm

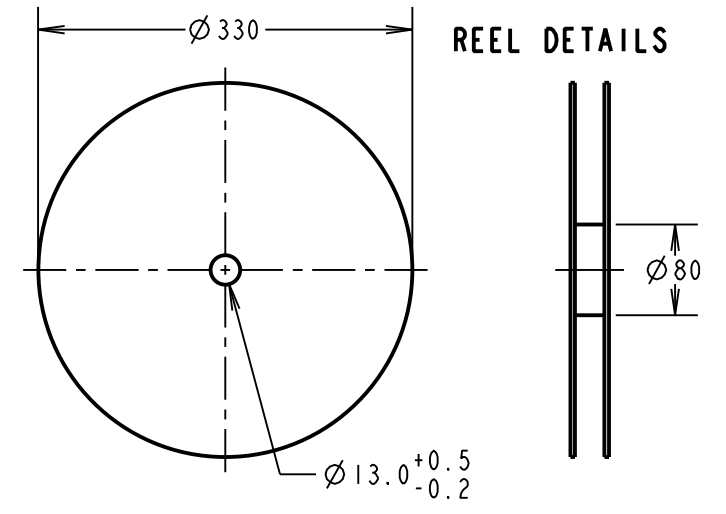
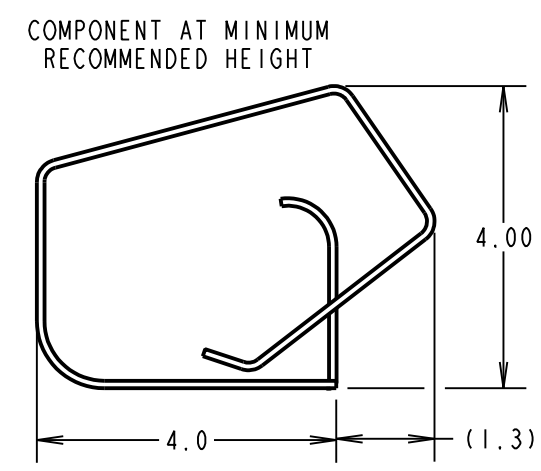
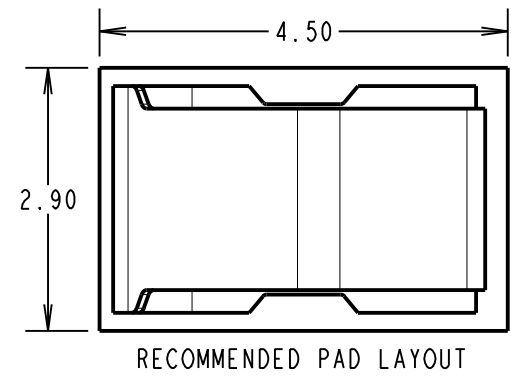
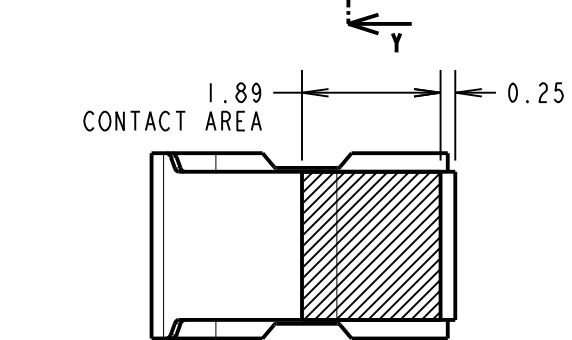
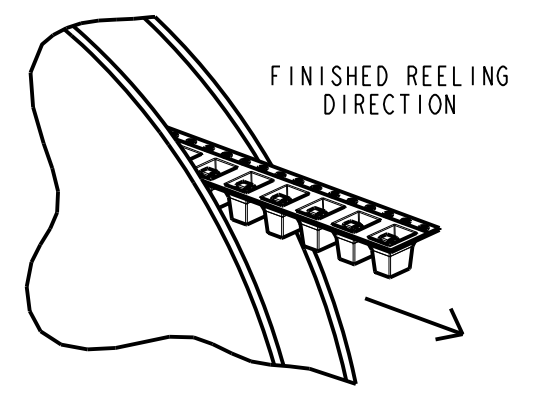
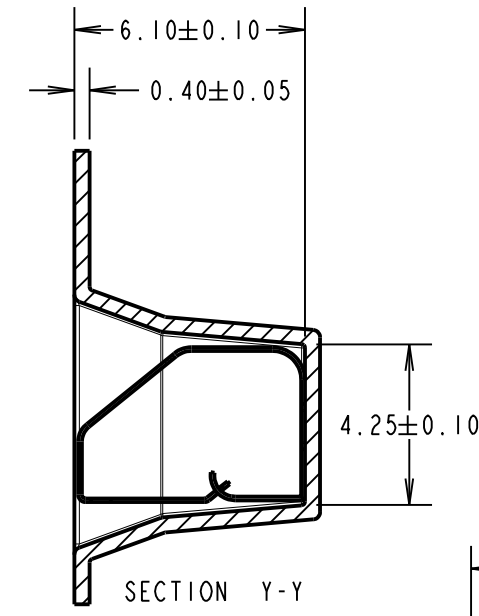
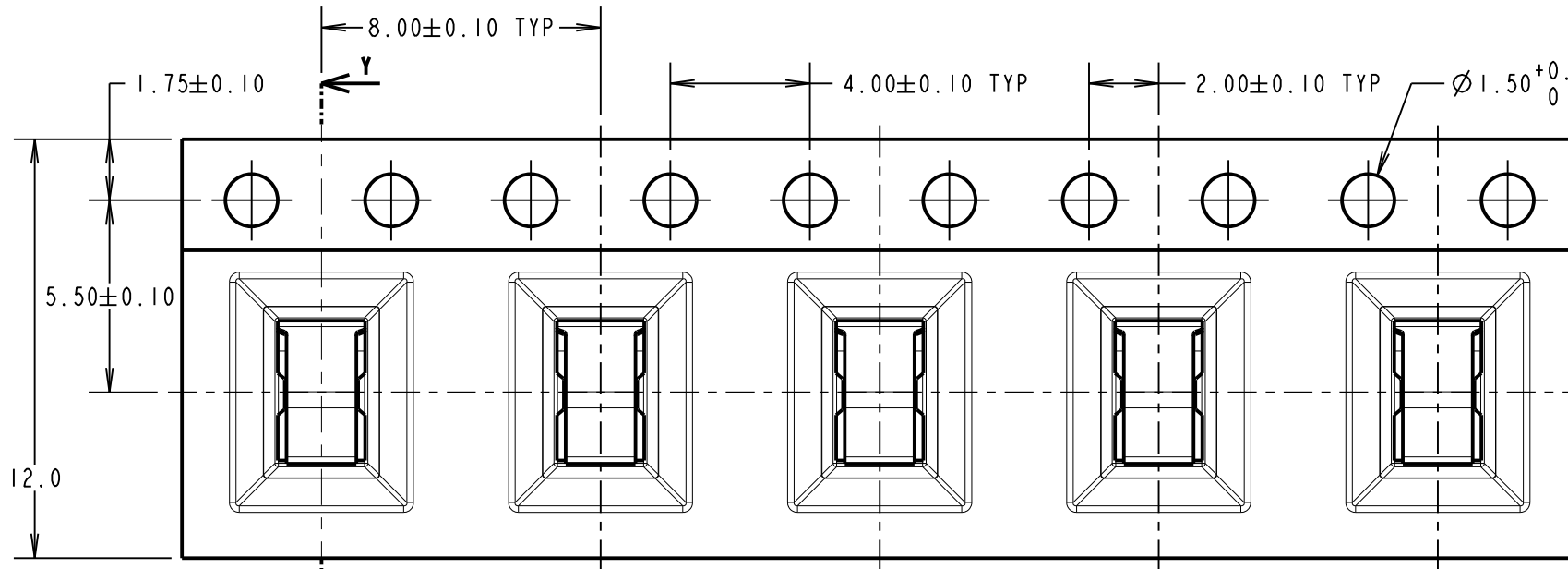

COMPONENT DETAILS

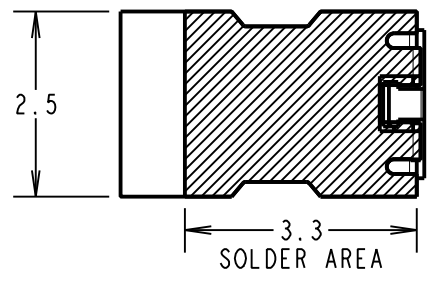
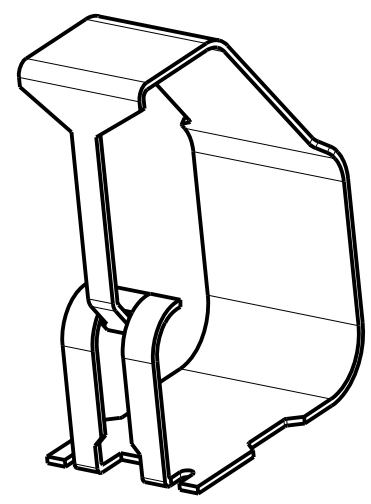
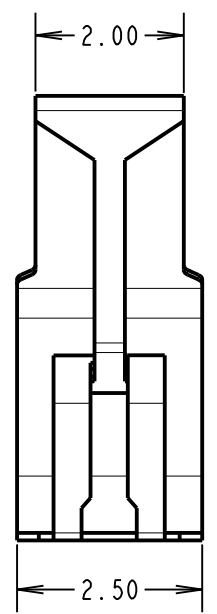
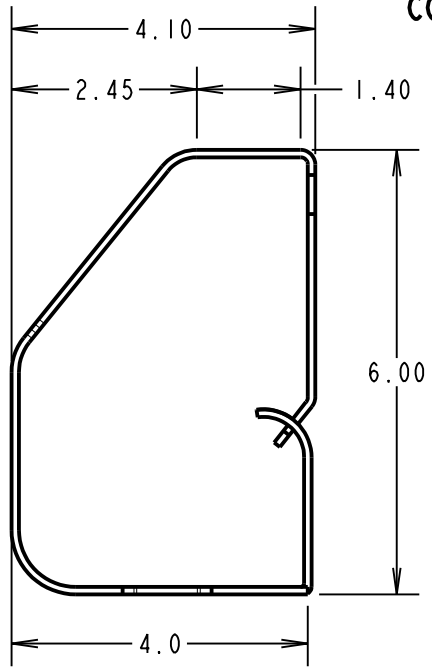

- NOTES:
 1. QUANTITY PER REEL = 1400.
 2. ALL TOLERANCES ARE: X.X = ±0.30mm
 X.XX = ±0.15mm
 UNLESS OTHERWISE STATED.

COMPONENT SPECIFICATION
 MATERIAL = TITANIUM COPPER ALLOY, 0.10mm THICK
 FINISH = 0.7µm - 1.3µm NICKEL, GOLD FLASH ON CONTACT
 AND 2.54µm MIN 100% MATTE TIN ON FOOT AREA.
 RECOMMENDED WORKING HEIGHT = 4.50mm / MIN FORCE = 1.2N
 RECOMMENDED MINIMUM WORKING HEIGHT = 4.00mm
 ELECTRICAL:
 CURRENT = 4A
 MECHANICAL:
 DURABILITY = 2500 CYCLES
 ENVIRONMENTAL:
 OPERATING TEMPERATURE = -55°C TO +125°C

MGP	8	11.01.22	31219
NAME	ISS.	DATE	CN/CO
APPROVED: MGP			
CHECKED: RTP			
DRAWN: R. ADDE			
CUSTOMER REF.:			
ASSEMBLY DRG:			

HARWIN
 www.harwin.com
 technical@harwin.com

THIS DRAWING AND ANY INFORMATION OR DESCRIPTIVE MATTER SET OUT HEREON ARE CONFIDENTIAL AND COPYRIGHT PROPERTY OF THE HARWIN GROUP AND MUST NOT BE DISCLOSED, LOANED, COPIED OR USED FOR MANUFACTURING, TENDERING OR FOR ANY OTHER PURPOSE WITHOUT THEIR WRITTEN PERMISSION.

TOLERANCES
 X = ±1mm
 X.X = ±0.50mm
 X.XX = ±0.20mm
 X.XXX = ±0.01mm
 ANGLES = ±5°
 UNLESS STATED

MATERIAL: SEE ABOVE
FINISH: SEE ABOVE
S/AREA: mm²

TITLE: SMT SHIELD FINGER (6mm) IN TAPE AND REEL
DRAWING NUMBER: S7051-42R
 SHT 2 OF 2