

WSMHP Series

- TO-263 surface mount package
- Very low thermal resistance
- Non-inductive, 20, 25 and 35 watt high power resistors
- Low profile package for high density PCB installation
- Suitable for board mounting with either solder or clip
- AEC-Q200 qualified

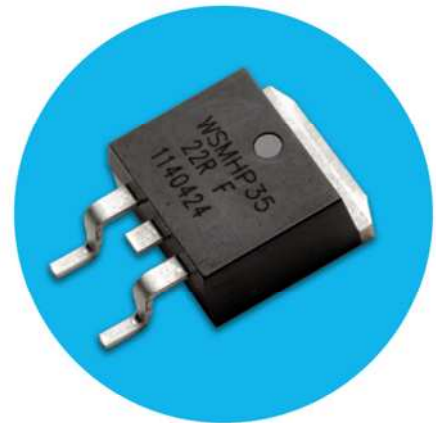

All parts are Pb-free and comply with EU Directive 2011/65/EU (RoHS2)

Electrical Data

		WSMHP20	WSMHP25	WSMHP35	Conditions
Power rating	watts	20	25	35	Heatsink with 25°C flange temperature
Power rating	watts	2.5			Without heatsink
Thermal resistance	°C/W	3.3			Resistor hotspot to flange
Limiting element voltage	volts	500			dc or ac rms
Resistance range	ohms	0R5 – 100K			
Dielectric strength	volts	2000			dc for 60s
Working temperature range	°C	-55 to 175			
Insulation resistance	ohms	>10G			Between terminals and tab
Tolerances	%	≤1R0: ±5 >1R0: ±1, ±5			
TCR	ppm/°C	≤3R0: ±300	>3R0-10R: ±100	>10R: ±50	25 to 105°C
Standard values		E24 preferred			

Physical Data

Dimensions (mm) & Weight (g)	
A	10.1 ±0.3
B	10.1 ±0.3
C	4.6 ±0.2
D	5.0 ±1
E	1.27 ±0.3
F	2.54 ±0.5
G	3.2 ±0.2
H	0.43 ±0.07
J	0.88 ±0.12
K	1.32 ±0.15
L	5.08 ±0.1
M	1.35 ±0.1
O	1.5 ±0.5
P	2.54 ±0.1
P1	0 to 3°
P2	0 to 3°
Q	6.9 ±0.3
R	0 to 0.254
T	6.0 ±1
Wt	1.5 nom.

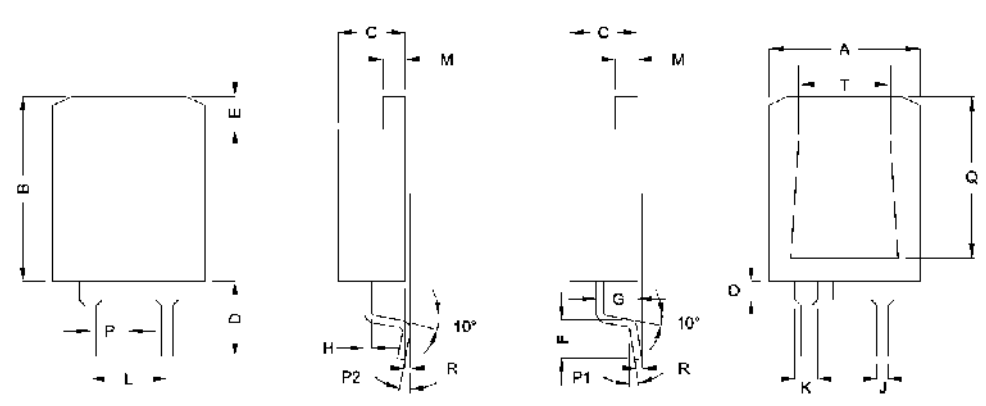

General Note

TT Electronics reserves the right to make changes in product specification without notice or liability. All information is subject to TT Electronics' own data and is considered accurate at time of going to print.

Performance Data

Test	Performance
Load at Rated Power: 2000hrs at rated power	±ΔR% 1
Short Term Overload: 2 x rated power with applied voltage not to exceed 1.5 x maximum continuous operating voltage for 5 seconds	±ΔR% 0.3
High Temperature Exposure: MIL-STD-202 method 108, at 175°C for 1000hrs, no load	±ΔR% 0.25
Temperature Cycling: JESD22 method JA-104, -55°C/175°C, 1000cycles	±ΔR% 0.3
Biased Humidity: MIL-STD-202 method 103, 1000hrs 85°C/85% RH, 10% of operating power	±ΔR% 0.5
Mechanical Shock: MIL-STD-202 method 213	±ΔR% 0.5
Vibration: MIL-STD-202 method 204, peak acceleration 5g for 20min, 12 cycles each of 3 orientations, 10-2000Hz	±ΔR% 0.2
Resistance to Soldering Heat: JIS-C-5201-1 4.18 IEC 60115-1 4.18, 260±5°C for 10 seconds	±ΔR% 0.5
HBM ESD: AEC-Q200-002, human body 25kV (AD)	±ΔR% 1
Solderability: J-STD-002, 240±5°C for 3 seconds	≥90% coverage
Moisture Resistance: MIL-STD-202 method 106, 10 cycles, 24hours	±ΔR% 0.5
Bending Strength: AEC-Q200-005, Bending 2mm for 60 seconds	±ΔR% 0.25
Terminal Strength: AEC-Q200-006, 1.8Kg for 60 seconds	±ΔR% 0.2

Temperature Derating

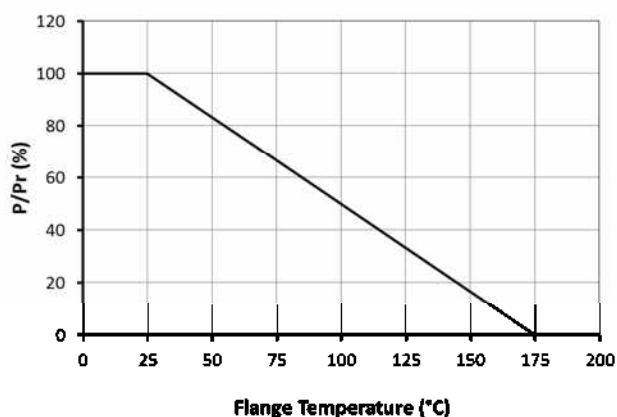

Typical Thermal Performance on FR4 Pad Heatsink

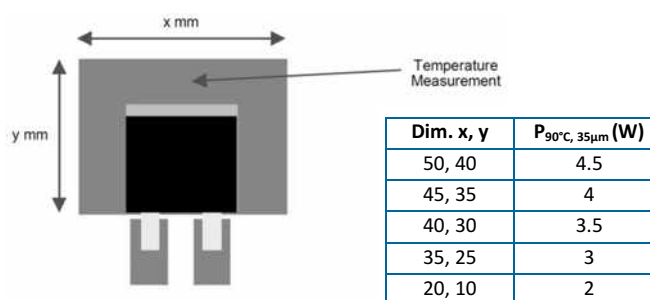

Characterisation carried out using 35μm PCB copper pad weights, with temperature of 90°C used as a maximum reference on the PCB. P_{90°C, 35μm} (W) is power when the measurement point reaches 90°C.

Pulse Performance

Single Pulse (P_{mean} << P_i) Condition

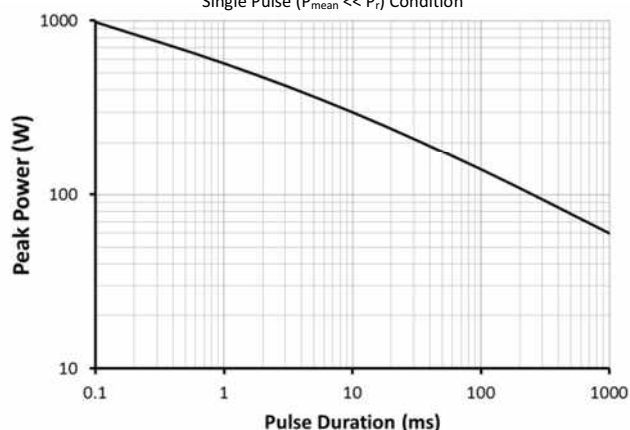

Pulse performance for durations ≥1s is dependent on mounting conditions. The short term overload power limit is 2 x power rating for 5s.

Typical High Frequency Performance

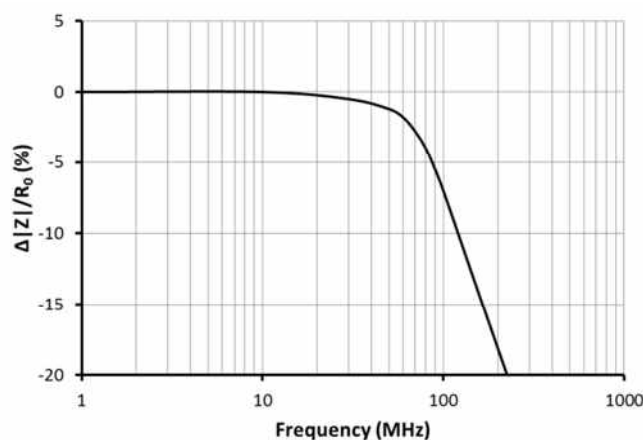

Typical high frequency characteristics for WSMHP35-220R. Self resonant frequency is 1GHz.

General Note

TT Electronics reserves the right to make changes in product specification without notice or liability. All information is subject to TT Electronics' own data and is considered accurate at time of going to print.

WSMHP Series

Packing

WSMHP components are packed on 330mm diameter reels, with 100mm inner diameter, in tape of width 24mm and with a quantity of 500 pieces per reel. The dimensions of the tape and orientation of the component are as shown below.

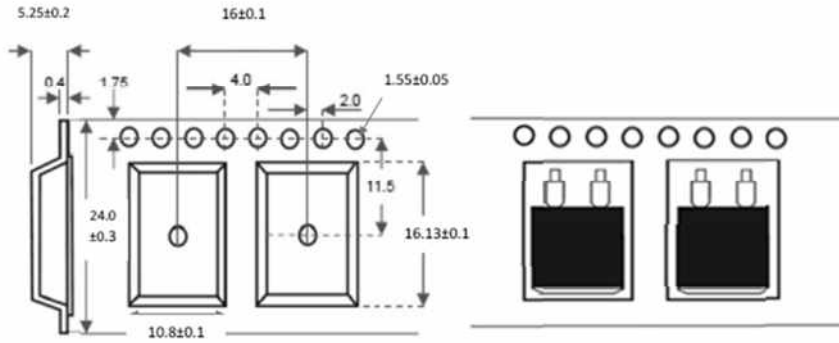

Ordering Procedure

Example: WSMHP35-10KJ (WSMHP35 at 10 kilohms ±5%, Pb-free)

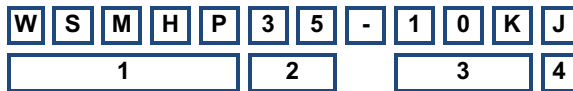

1	2	3	4	
Type	Rating	Value	Tolerance	Packing
WSMHP	20	3 / 4 characters	F = ±1%	Plastic tape 500/reel
	25		J = ±5%	
	35	R = ohms K = kilohms		

General Note

TT Electronics reserves the right to make changes in product specification without notice or liability. All information is subject to TT Electronics' own data and is considered accurate at time of going to print.