

FELLER GMBH

A-2525 GUENSELSDORF, AUSTRIA - TEL.: . . 43(2256) 62 32 50 - FAX: . . 43 (2256) 62 32 57
e-mail: sales@feller-at.com <http://www.feller-at.com>

Description: 498G-SVT3x18AWG-g25/2,0m,black

L11

1. PLUG: Type 498G

Molded plug according to : NEMA 5-15
Rated current and voltage : 15A, 125V AC
Plugbase : thermoplastic Polyester(PBTP) GFR
Pins : solid brass, nickel-plated, crimped
Pins dimension : grounding O.D. 4,8 mm
line and neutral 6,20 mm x 1,40 mm
Outer mold : PVC compound, hardness Shore A 75-77
Approvals : UL, CSA

2. CORD: Type SVT3x18AWG

Flexible cord according to : UL62, CSA 22.2 No.49
Marked : *JF* E41542*LL14903*SVT3x18AWG*FT2*UL*CSA*
Number of cores : 3
Conductor construction : 48 x 0,15 mm O.D. 1,25mm
Conductor insulation : Extruded PVC, O.D. 2,10mm
Jacket : Extruded PVC, O.D. 6,20 mm +/-0,20mm
Electrical resistance of conductors : max. 22,37 Ohm/km
Dielectric strength : 2000 V
Approvals : UL, CSA

3. 2.end: g25

25 mm jacket removed

TESTING

Electrical testing : 100%
Visual inspection : 100%
High pot test wire to wire : 3 kv for 2 sec.
Continuity test : 25A to grounding / 20A to line and neutral
Polarity test : yes
Skin high pot test : 6kv line to skin

Tolerances not indicated in the drawing: +/- 2 %
design subject to change without prior notice

DATE of ISSUE:	April, 2003
REV: 2 1	ORIG: mk

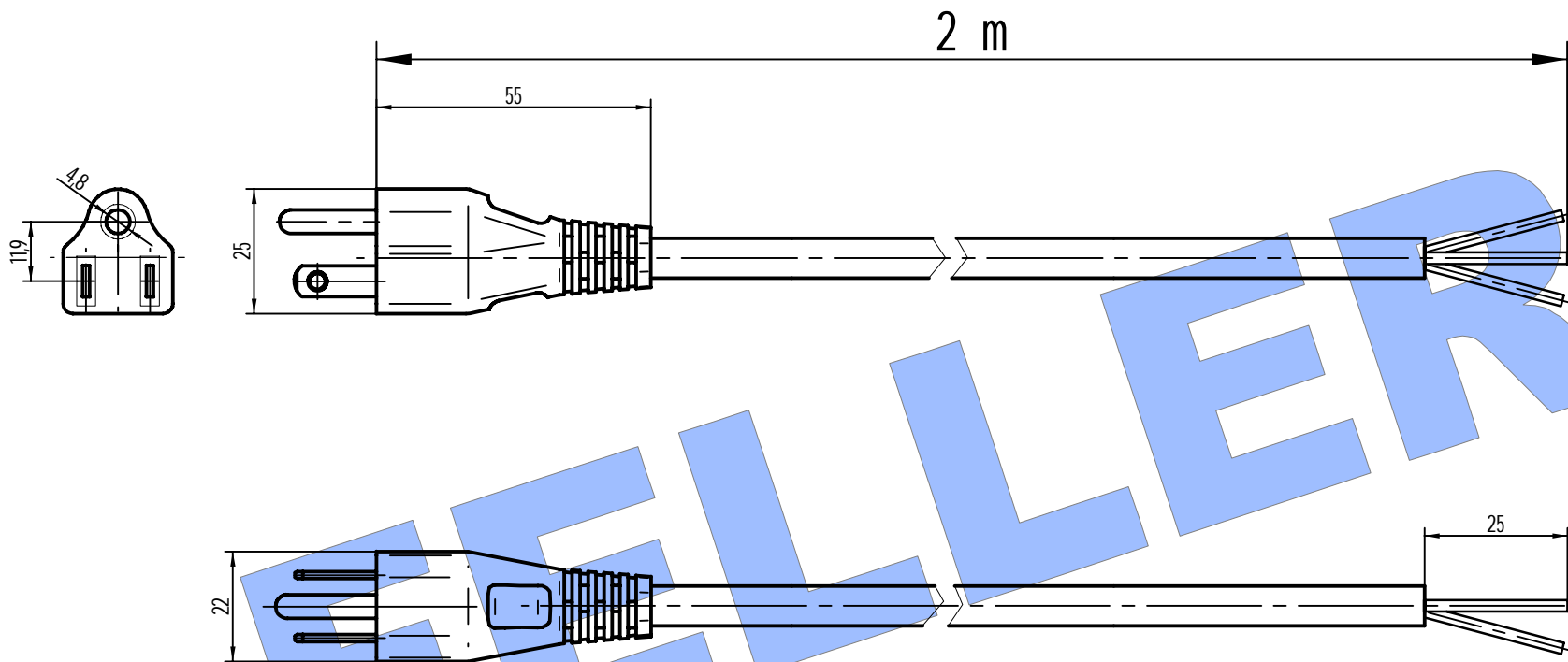

1.
498G

2.
SVT3x18AWG

3.
g25

Feller Type: 498G - SVT3x18AWG - g25 / 2.0 m, black (L11)

02.04.03

All dimensions in mm

FELLER 

A-2525 Günselsdorf, Austria

Telefon 0043-2256-62325-0

Fax:0043-2256-62325-7

email: sales@feller-at.com

http://www.feller-at.com