

TriBoard Manual TC3X4L

Hardware: TriBoard TC3X4L TH V1.0 and TriBoard TC3X4L V1.0

About this document

Scope and purpose

The User Manual provide information about using, configuration and connecting the TriBoard with Infineon AURIX™ TC3X4 LQFP device. The manual provide information for different hardware types. There exist different hardware with Through Hole socket (TriBoard TC3X4L TH) and soldered devices (TriBoard TC3X4L). The schematic is identically for the all boards if not other mentioned in chapter schematic. The placing on the boards is the same, all components are on the same location.

Intended audience

Design, verification, test and software engineers will use this document to get an understanding of the functionality and connections of the TriBoard.

Table of Contents

	About this document	Preface-1
	Table of Contents	TOC-2
1	Introduction	1-1
2	Features	2-1
2.1	Summary of Features	2-1
2.2	Block Diagram	2-2
2.3	Placement	2-3
3	TriBoard Information	3-1
3.1	Soldered board	3-1
3.2	Socketed board	3-1
3.2.1	Usable devices	3-1
3.2.2	Restricted usable devices	3-1
3.3	Power Supply	3-1
3.3.1	Failsafe handling	3-2
3.4	LEDs	3-2
3.5	Clock	3-3
3.6	USB Connector	3-3
3.6.1	Serial Connection to PC	3-3
3.6.2	miniWiggler JDS	3-4
3.7	FlexRay™ (E-RAY)	3-4
3.8	Serial Eeprom	3-4
3.9	MultiCAN	3-4
3.10	LIN	3-5
3.11	Ethernet	3-5
3.12	HSCT (optional)	3-6
3.12.1	High speed with HSCT	3-6
3.13	ADC	3-7
3.14	Other peripherals	3-8
3.15	Toggle LED's	3-8
3.16	Buttons	3-8
3.17	Debug System	3-9
3.17.1	OCDS1	3-9
3.17.2	DAP	3-9
3.17.3	DAP_SCR	3-9
3.17.4	High speed with DAP	3-9
3.17.5	ETK connector (optional)	3-10
3.17.6	EmW Power (optional)	3-10
4	TriBoard Configuration	4-1
4.1	HW Boot Configuration	4-1
4.1.1	Default Pad State	4-1
4.1.2	Bootmode	4-1
4.2	Assembly Options	4-2
4.2.1	General optional resistors	4-2
4.2.2	Resistors for peripherals	4-4
5	Signal (on board used) Description	5-1
5.1	Power Signals	5-1

Table of Contents

5.2	Reset Signals	5-1
5.3	Config Signals	5-2
5.4	Clock Signals	5-2
5.5	Debug Signals	5-2
5.6	Peripheral Signals	5-2
6	Connector Pin Assignment	6-1
6.1	On Board only used signals	6-1
6.2	TC3X4 Connector / Top View	6-2
6.3	Power connector pinout	6-4
6.4	USB connector pinout	6-4
6.5	FlexRay™ (ERAY) connector pinout	6-4
6.6	CAN connector pinout	6-4
6.7	LIN connector pinout	6-5
6.8	HSCT connector pinout	6-5
6.9	Ethernet connector pinout	6-5
6.10	OCDS1 connector pinout	6-6
6.11	DAP connector pinout	6-6
6.12	ETK connector pinout	6-7
6.13	Ethernet miniWiggler power connector pinout	6-7
7	Schematic and Layout	7-1
7.1	Known problems	7-1
7.1.1	Known problems on TriBoard TC3X4L TH V1.0	7-1
7.1.2	Known problems on TriBoard TC3X4L V1.0	7-1
7.2	Schematic	7-1
7.3	Layout	7-9
7.4	Layout with Dimensioning	7-11

Introduction

1 Introduction

We congratulate you on your purchase of the TriCore Evaluation Board. This kit is a versatile tool, providing quick access to the capabilities of TriCore's powerful architecture.

Applications can be developed easily. The Evaluation Board is equipped with a variety of memories and peripherals for connection to the environment. There is also an interface for the On Chip Debugging Features (OCDS1 and DAP).

The Evaluation Board allows easily the development of TriCore applications with the corresponding tools.

Subsequently, the applications can be downloaded and can be tested with the powerful debugger software.

This TriBoard Hardware Manual familiarizes you with the TriCore Evaluation Board and guides you through the initial configuration of the TriBoard.

For detailed technical information about the TC3X4 LQFP (e.g. TC374, TC364) please refer to the User Manual of the used device.

Features

2 Features

2.1 Summary of Features

- Infineon's TC3X4 (TC374, TC364) AURIX™ 2G Controller in LQFP-144 Package
- FlexRay™¹⁾ Transceivers
- High Speed CAN Transceivers (CAN-FD capable)
- USB to UART bridge
- Ethernet PHY
- Serial Eeprom
- LIN Transceiver
- Crystal 20MHz (default) or External Clock
- USB miniWiggler JDS for easy debugging
- 8 Low Power Status LEDs
- 8-DIP switches for configuration
- access to all pins of controller
- 100mm x 160mm (EURO-Board)

Connectors

The TC3X4L TriBoard offers a wide variety of connectors:

- Standard power connector
- Micro USB connector for ASC Interface (ASC0) and miniWiggler
- RJ45 connector for Ethernet
- 16-pin header for JTAG interface (OCDS)
- 2 x 10-pin header for DAP and DAP_SCR
- 10pin (2x5) Header for LIN Transceiver (LIN)
- 2 x 10pin (2x5) Header for CAN High Speed Transceiver (CAN0 and CAN1)
- 2 x 10pin (2x5) Header for FlexRay™ (ERAY-A and ERAY-B)
- four 80-pin connectors (male) + four 80-pin connectors (female) with all I/O signals
- optional ETK connector
- optional 6pin (IEEE1394) Socket for HSCT

Components

- Infineon's Multi Voltage Safety Micro Processor Supply TLF35584QV
- Three LEDs to validate power supply (5Volt / 3,3 Volt / 1,25 Volt)
- LED indicating safe state signal 2 from TLF35584
- LED indicating /HDRST (ESR0) active state
- LED indicating activ miniWiggler JDS
- LED switched via DAS software
- 2 x Infineon's FlexRay™ Transceiver TLE9221SX
- 2 x Infineon's High Speed CAN-Transceiver TLE9251VSJ
- Infineon's LIN-Transceiver TLE 7259-3GE
- USB to UART bridge FT2232HL (FTDI)
- Single-Chip/Port 10/100M Ethernet PHYCEIVER with Auto MDX RTL8201FI-VC-CG (Realtek)
- 8 general purpose LEDs
- 2K I²C Serial Eeprom with EUJ-48™²⁾ Node Identity (MICROCHIP)

1) FlexRay™ is a trademark of FlexRay Consortium.

Features

- Reset switch
- Enable switch
- Generic switch
- 4-pin Dip switch

Zero Ohm Bridges

Zero Ohm resistors give the flexibility to configure the systems functionality.

2.2 Block Diagram

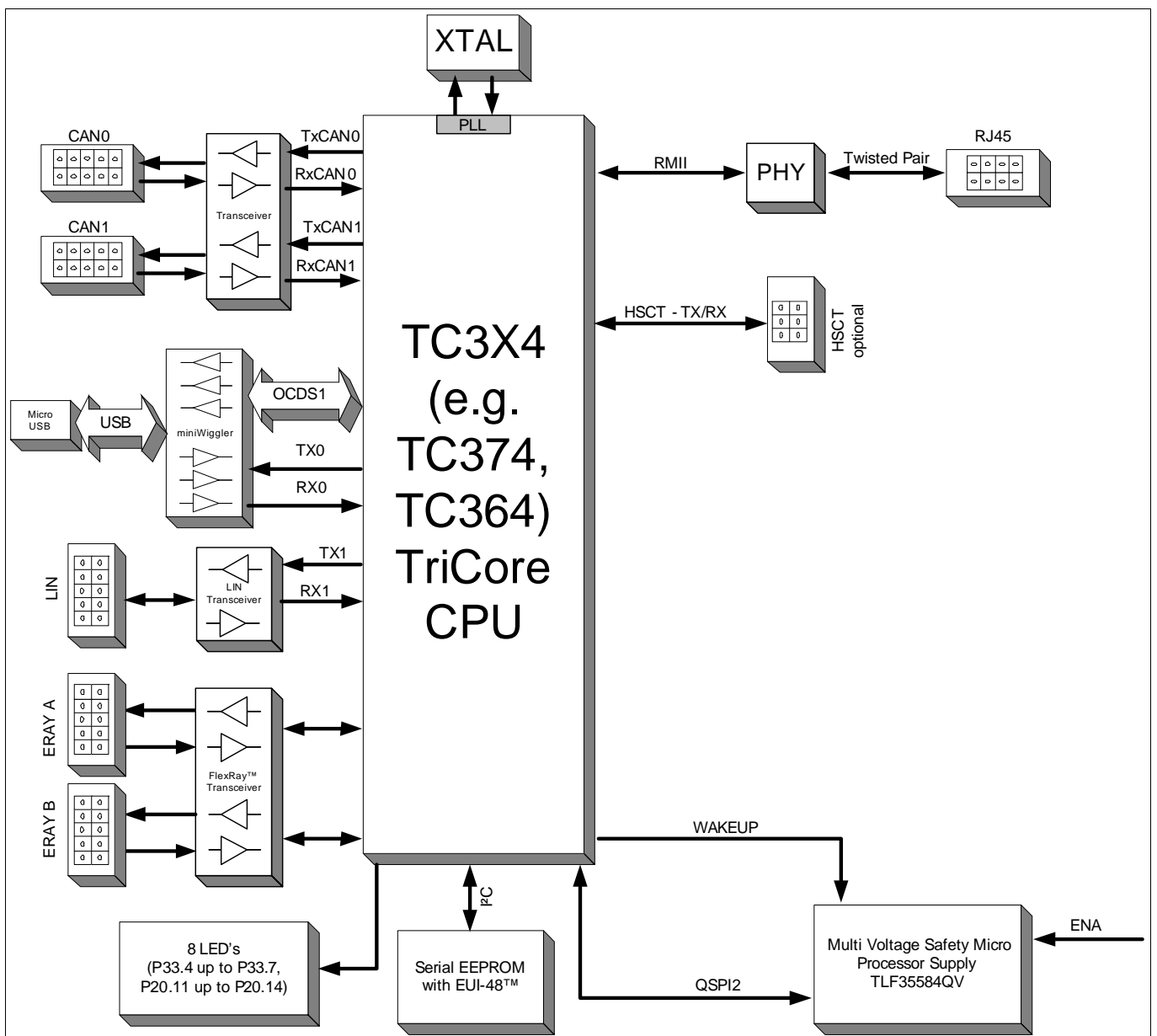

Figure 2-1 TriBoard Block Schematic

2) EUI-48™ is trademarked by IEEE

Features

2.3 Placement

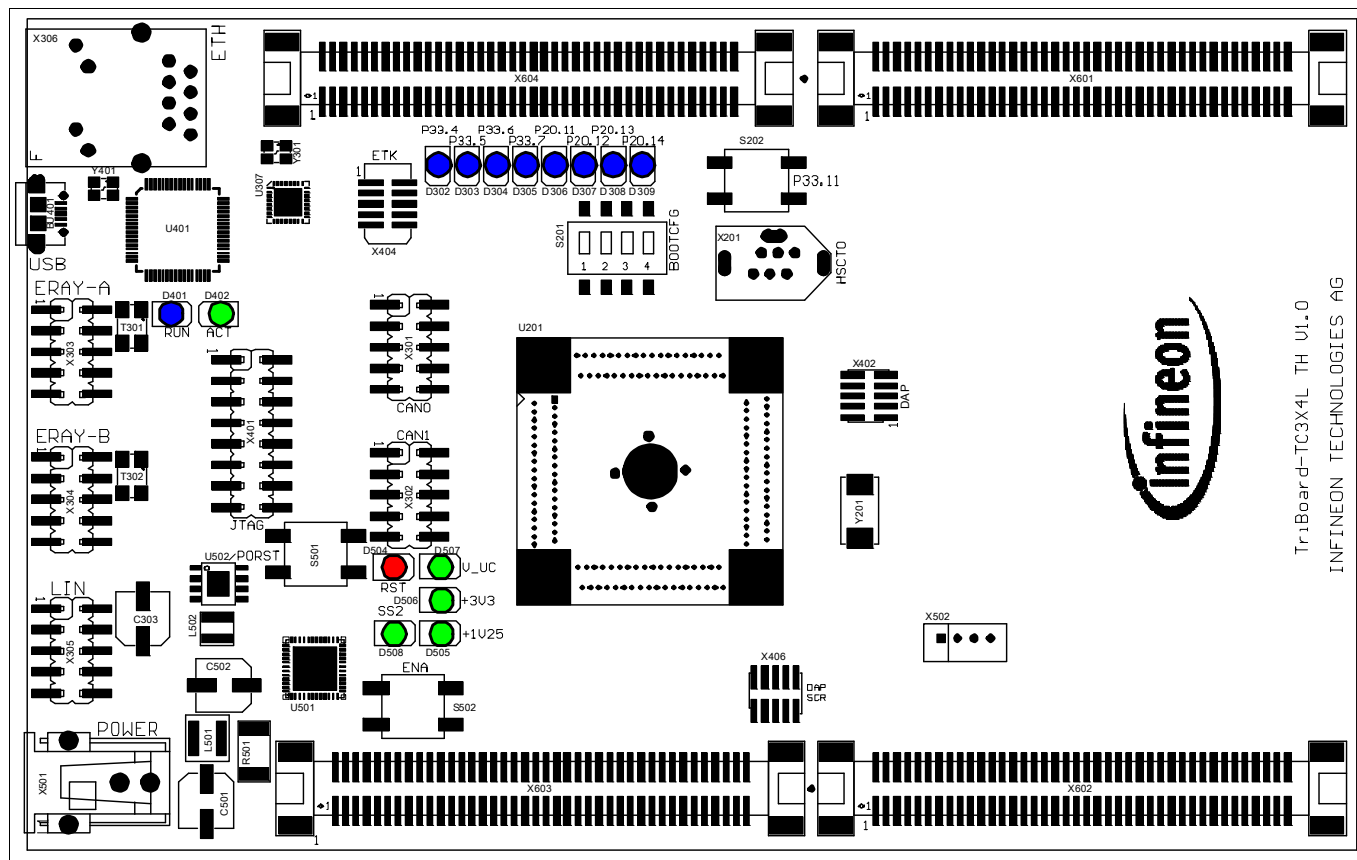

Figure 2-2 TriBoard TC3X4L (TH) V1.0 Placement

3 TriBoard Information

3.1 Soldered board

TriBoard TC3X4L V1.0 is the soldered board and will be available only with usable devices. Please see also chapter [Usable devices](#).

3.2 Socketed board

TriBoard TC3X4L TH V1.0 is the socketed board.

3.2.1 Usable devices

Note: Please check always the latest manual for complete list of usable/tested devices.

The board can be used with the following devices:

- TC374
- TC364DP-64F300W

Note: For TC364: AN42 is connected directly to ground and AN43 is connected to VDDM via R223. Additional there is a capacitor (CB206) between AN43 and AN42.

3.2.2 Restricted usable devices

- None

3.3 Power Supply

All needed voltages are generated via Infineon's Multi Voltage Safety Micro Processor Supply TLF35584QV and via the microcontroller itself (+1,25V).

The supply device is available as two different devices:

TLF35584QVWS1 -> +5V standby voltage, +5V TriCore supply (V_UC)

TLF35584QVWS2 -> +3,3V standby voltage, +3,3V TriCore supply (V_UC)

Dependent of the assembled device the board works with 5V or 3,3V IO.

The TLF35584QV provide the following voltages:

+3,3V or +5V for standby (connected to VEVRSB)

+3,3V or +5V for TriCore (connected to VEXT)

+5V communication supply (used by CAN and FlexRay™ transceivers)

+5V voltage reference (connected to VDDM and VAREF_x)

+3,3V via LDO directly from pre regulator (used by Ethernet PHY)

Applying a stable supply voltage causes the power on reset after a short period. The three LED's (V_UC, +3.3V, +1V25) indicate the status of the on board generated voltages.

A manual power on reset is executed by pressing the reset button.

The Board has to be connected to a +3,5V to +40V DC power supply.

The power consumption is not specified yet but a supply with 12V and 500mA is recommended. The pinout for the supply connector is shown in [Figure 6-3](#). There can be used any standard power pack with a connector where the positive line is surrounded by the ground line.

TriBoard Information

3.3.1 Failsafe handling

In case that the device don't contains a program which disable or service the window watchdog and error pin monitor of the TLF35584 then the TLF35584 is going to a FAILSAFE state where all supplies are switched off. This state can be left via reconnect the power plug or via the ENA button (S502). In this case you must connect a debugger which is able to disable the window watchdog and error pin monitor to reprogram the microcontroller. In the default state of the board the switching to FAILSAFE state is switched off via resistor R508.

If you will use/evaluate all safety features of the TLF35584 make sure that R509 is assembled and R508 is not assembled. Make sure that you have a proper initialization of TLF35584 in your software.

Resistor R508 and R509 are red marked in the following **Figure 3-1**:

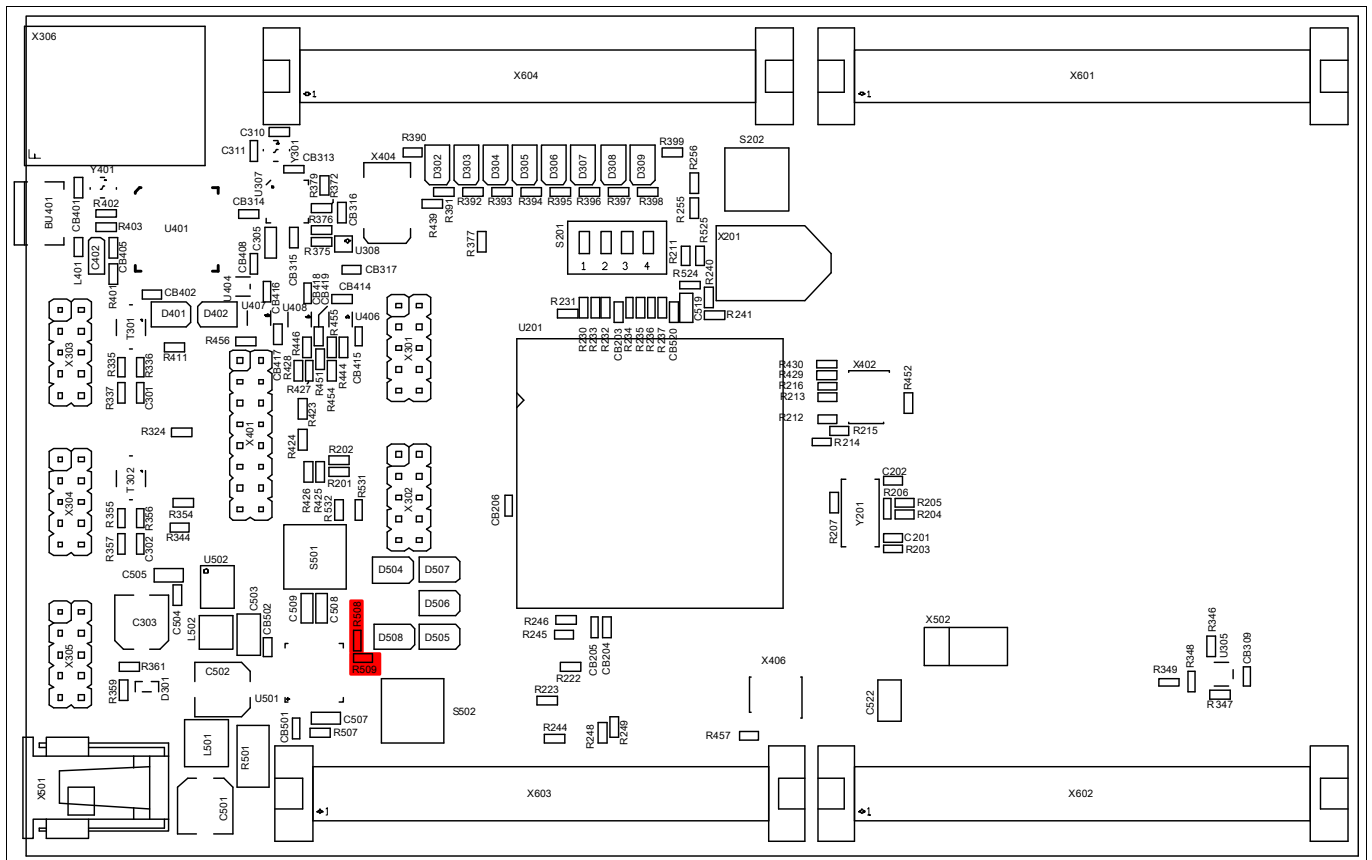

Figure 3-1 Resistors for TLF35584 Safety feature handling with switch on

3.4 LEDs

There are 15 LEDs on board:

- D302 up to D305 (blue) -> toggle LEDs connected to P33.4 ... P33.7
- D306 up to D309 (blue) -> toggle LEDs connected to P20.11 ... P20.14
- D504 RST (red) -> RESET LED indicate the reset state of the board (/ESR0)
- D505 +1V25 (green) -> +1V25 power supply indication
- D506 +3V3 (green) -> +3,3V power supply indication
- D507 V_UC (green) -> +5V/+3,3V power supply indication
- D508 SS2 (green) -> safe state signal 2 indication
- D402 ACT (green) -> on board miniWiggler JDS is ACTIV
- D401 RUN (blue) -> Debug RUN mode (switched by DAS Server)

TriBoard Information

3.5 Clock

On the board is a fixed crystal with 20MHz assembled. You can change this by replacing Y101 (soldered).

3.6 USB Connector

The USB connector is used for connection to a PC. Via the USB it is possible to power the board, using the ASCLIN0 as serial connection via USB and Debugging via DAS. For the pinout of USB socket see [Figure 6-4](#).

NOTE: Before connecting the board to the PC, make sure that the actual DAS software is installed on the PC. For actual DAS software please contact your local FAE.

The software can also be found on:

[DAS website](#)

3.6.1 Serial Connection to PC

After the first connection of USB to a PC the needed driver will be installed automatically. During this there will be created a new COM port on PC. This COM port can be used to communicate with the board via ASCLIN0 of the device. Per default the ASCLIN0 is used on P14.0 and P14.1 (e.g. Generic Bootstrap Loader) . In case you will use the Generic Bootstrap Loader via CAN or ASCLIN0 via P15.2 and P15.3 you must:

- remove R436 and R437 (this disconnect the serial connection from P14.0 and P14.1)
- remove R301 and R302 (this disconnect the CAN0 transceiver from P20.7 and P20.8)
- assemble R438 and R440 with 0R resistor (size 0603) to connect P15.2 and P15.3 to serial connection
- assemble R303 and R304 with 0R resistor (size 0603) to connect P14.0 and P14.1 to CAN0 transceiver

The mentioned resistors are red marked in [Figure 3-2](#).

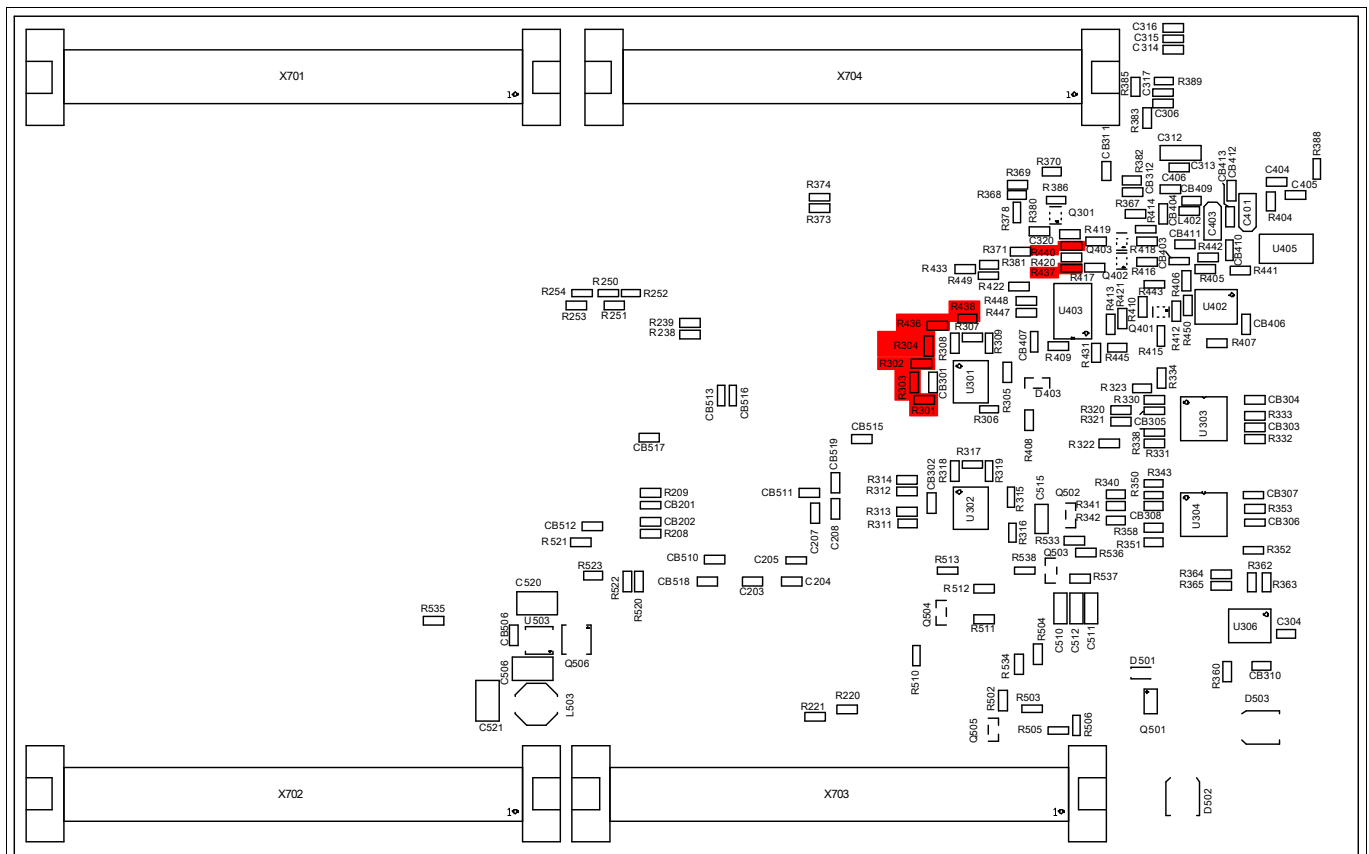

Figure 3-2 Resistors for ASC connection (ASC0)

TriBoard Information

3.6.2 miniWiggler JDS

The miniWiggler JDS is a low cost debug tool which allows you access to the JTAG of the device. Make sure that you have the latest DAS release. Debugging is possible via the DAS Server 'UDAS'. Please contact your preferred debug vendor for support of DAS.

If you have connected the board to the PC and there runs the DAS server, then a working connection is visible via the green ACTIV LED.

The status RUN LED is switched on/off through the DAS Server, depending on the used debugger (client).

IMPORTANT: Make sure that there is no or a tristated connection on X401 (OCDS1) and X402 (DAP) if the ACTIV LED is on.

Per default the miniWiggler is connected to the DAP. If resistors R214, R215 and R216 assembled (default) then the standard DAP is connected to miniWiggler. If all this resistors are not assembled then the miniWiggler can't be used. In this case only the DAP connectors X402 and X406 can be used. See [Figure 3-7](#).

3.7 FlexRay™ (E-RAY)

The board has 2 IDC10 plugs for FlexRay™ Communication (channel A and B) with up to 10 Mbit/s. For the pinout of the plugs see [Figure 6-5](#). You can use a IDC female connector with crimpconnector, flat cable and SUB-D 9 plug with crimpconnector to have a 1:1 adapter to SUB-D 9.

The transceiver are connected to the TriCore device via zero ohm resistors (R320 up to R324 and R340 up to R344) which must be removed to use the ports outside.

ERAY-A can be connected to P02.0, P02.1 and P02.4. Transceiver for channel A can be enabled/disabled via P10.1. The error state of transceiver channel A can be read out via P10.2.

ERAY-B is connected to P02.2, P02.3 and P02.5. Transceiver for channel B can be enabled/disabled via P20.10. The error state of transceiver channel A can be read out via P20.9.

For more information look in the user manual for TC3X4 LQFP.

3.8 Serial Eeprom

The I²C via P15.4 and P15.5 of the TC3X4 is connected to a serial EEPROM with a size of 2KBit (2 x 128 x 8). The slave address of this EEPROM is 0x50. The upper half of the array (80h-FFh) is permanently write-protected. Write operations to this address range are inhibited. Read operations are not affected. This upper half contains a pre-programmed EUI-48™ node address which can be used as MAC ID for Ethernet. The other 128 bytes are writable by customer.

To disconnect (disable) the EEPROM remove resistor R348 and R349.

3.9 MultiCAN

On the board are two CAN transceiver connected to the CAN0 and CAN1 of TC3X4 LQFP. The transceivers are connected to two IDC10 plug. For the pinout of IDC10 plug see [Figure 6-6](#). You can use a IDC female connector with crimpconnector, flat cable and SUB-D 9 plug with crimpconnector to have a 1:1 adapter to SUB-D 9.

The transceiver are connected to the TriCore device via zero ohm resistors (R301 up to R304 and R311 up to R314) which must be removed to use the ports outside.

CAN0 can be used via P20.7 and P20.8 (CAN0 node 0, default) or P14.0 and P14.1 (CAN0 node 1). CAN1 can be used via P13.0 and P13.1 (CAN1 node 0, default) or P00.0 and P00.1 (CAN1 node 0).

TriBoard Information

3.10 LIN

On the board is one LIN transceiver connected to the ASCLIN1 on TC3X4 LQFP (P15.0 and P15.1). The transceiver are connected to one IDC10 plug. For the pinout of IDC10 plug see [Figure 6-7](#). You can use a IDC female connector with crimpconnector, flat cable and SUB-D 9 plug with crimpconnector to have a 1:1 adapter to SUB-D 9.

To disconnect the LIN remove resistor R364 and R365.

The LIN can be used in master and in slave mode. For the master mode there is per default a pull-up of 1K (R360) and a capacitor of 1nF (C304) on the BUS assembled. For using the LIN in slave mode the pull-up resistor R360 must be removed and maybe the capacitor changed to a smaller value (e.g. 220pF).

The mentioned resistor and capacitor are red marked in [Figure 3-3](#)

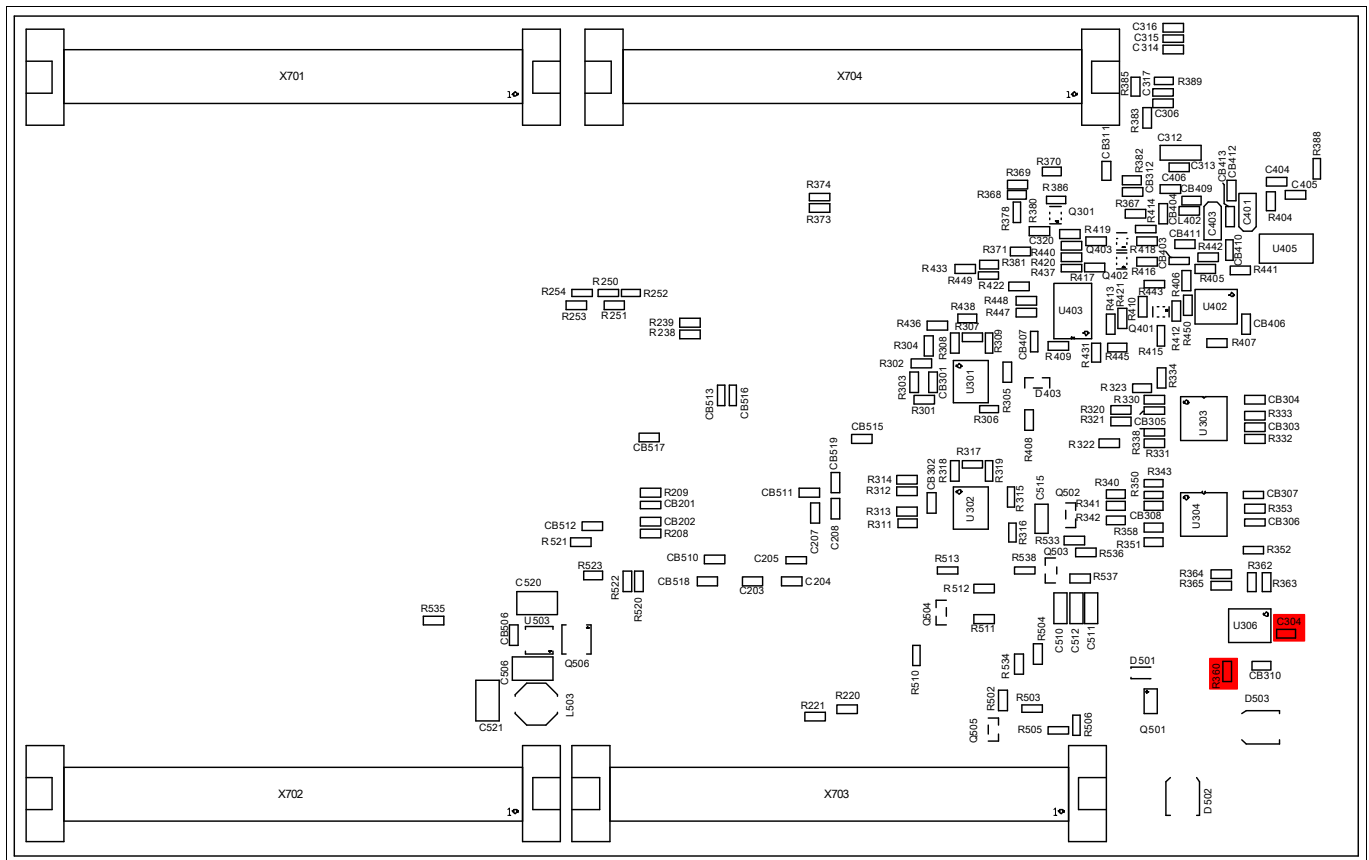

Figure 3-3 Components for LIN Master Mode

3.11 Ethernet

The TriBoard provide a RJ45 connector (X306) for twisted pair ethernet connections. The TriBoard use a Realtek Single-Chip/Port 10/100M Ethernet PHYCEIVER with Auto MDX RTL8201FI-VC-CG as physical interface device. For more information about the ethernet modul see TC3X4 User’s Manual, about the PHY see the RTL8201FI datasheet. For the pinout of RJ45 see [Figure 6-9](#).

The PHY is connected to the TriCore device via resistors and resistor arrays (R368 up to R374) which must be removed to use the ports outside.

For the connection between TriCore and PHY is used RMII.

For MD connection there is used P00.0 and P02.8. To use this communication way please make sure that R376 is not assembled (default). For R376 position please see also [Figure 4-4](#).

Note: Please note that the RGMII interface can’t be used of limited pin availability. Therefore Gigabit is not usable with this board only 10M and 100M.

TriBoard Information

3.12 HSCT (optional)

The TriBoard provide a footprint of IEEE 1394 socket (X201) for connection to other TC3XX via HSCT.

Note: Don't use X201 for connection to any IEEE 1394 device, this can destroy the board and/or the connected device.

For connect two TriBoards you need to assemble this socket (Lumberg 2415 01) on each board and connect the boards with a standard 6 pin IEEE 1394 cable. For the pinout of socket see [Figure 6-8](#).

3.12.1 High speed with HSCT

For use the HSCT connection between two board you need to remove 5 resistors to have a very short connection between device and connector. On the TC3X4L Triboard this 5 resistors are R250, R251, R252, R253 and R254 (red marked in [Figure 3-4](#)). This resistors needs to be removed.

Important: When the resistors are removed then the port signals P20.0, P21.2, P21.3, P21.4 and P21.5 are no longer available on the 80 pin samtec connectors.

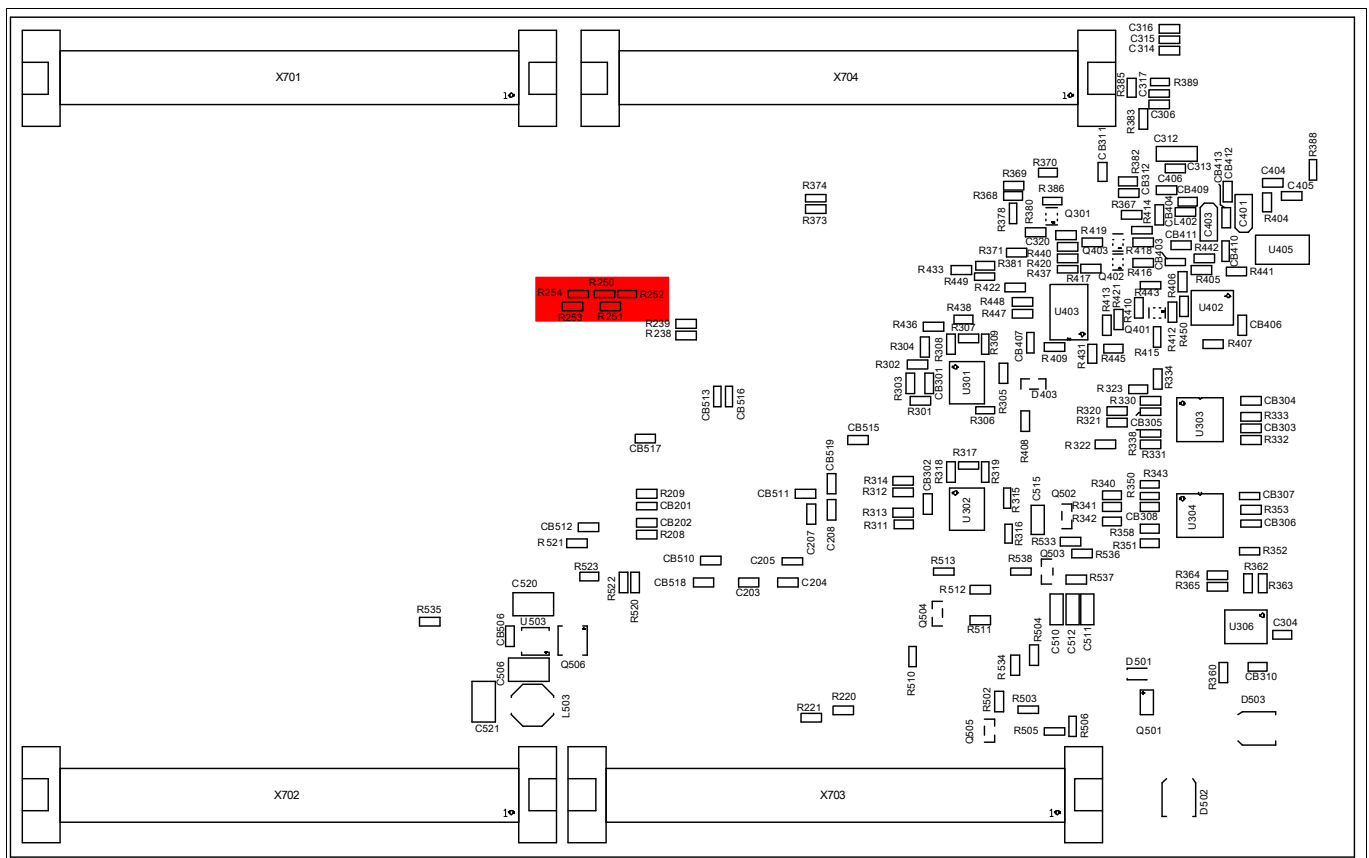

Figure 3-4 Resistors for high speed HSCT

TriBoard Information

3.13 ADC

On this boards are 5 ADC channels prepared with a low pass filter. On pin AN7, AN20, AN21, AN44 and AN45 is assembled a capacitor of 47nF and a serial resistor of 4,7K. The filter components are red marked in the following figures (Figure 3-5 and Figure 3-6).

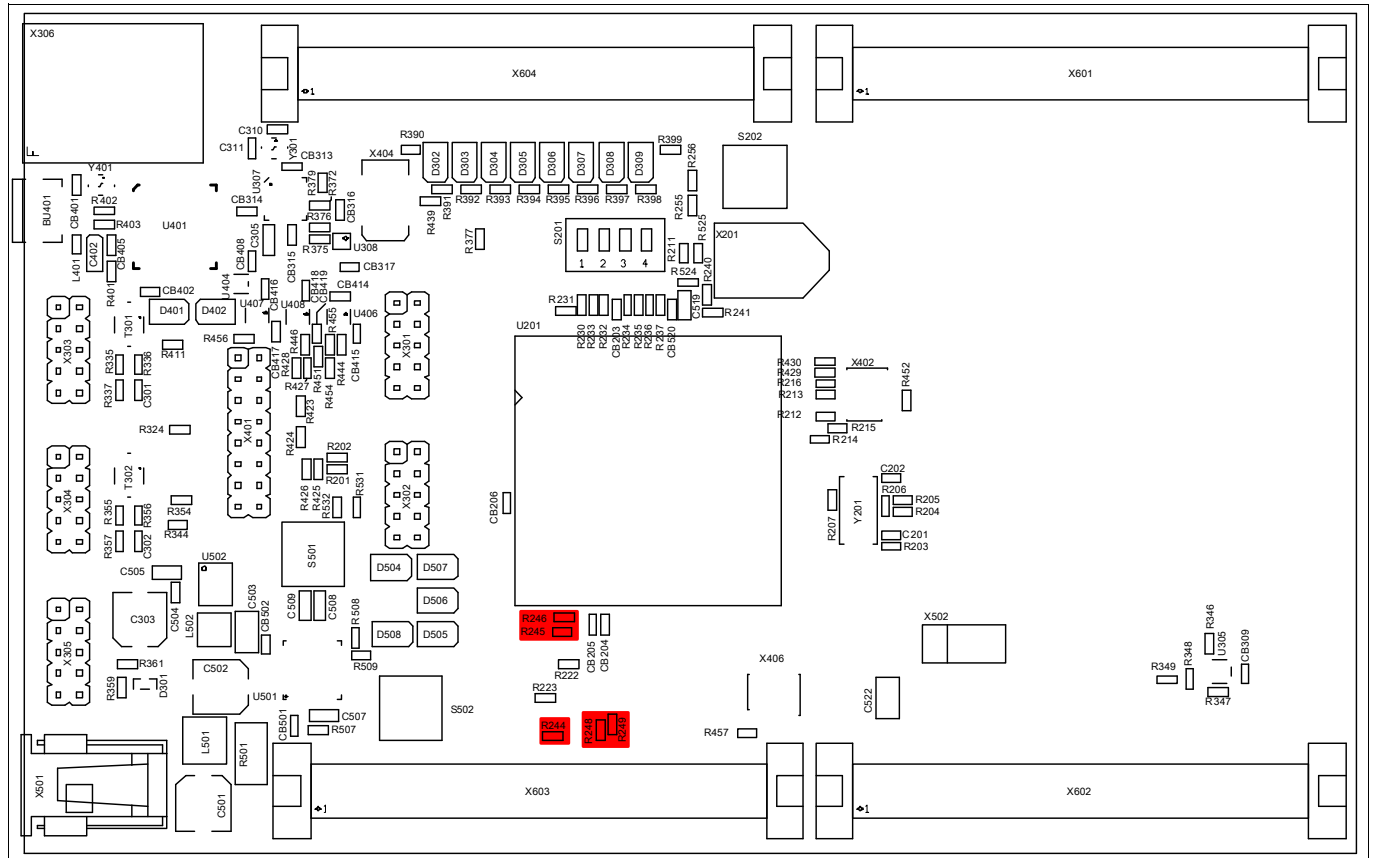

Figure 3-5 Filter components of ADC channels on Top Side

TriBoard Information

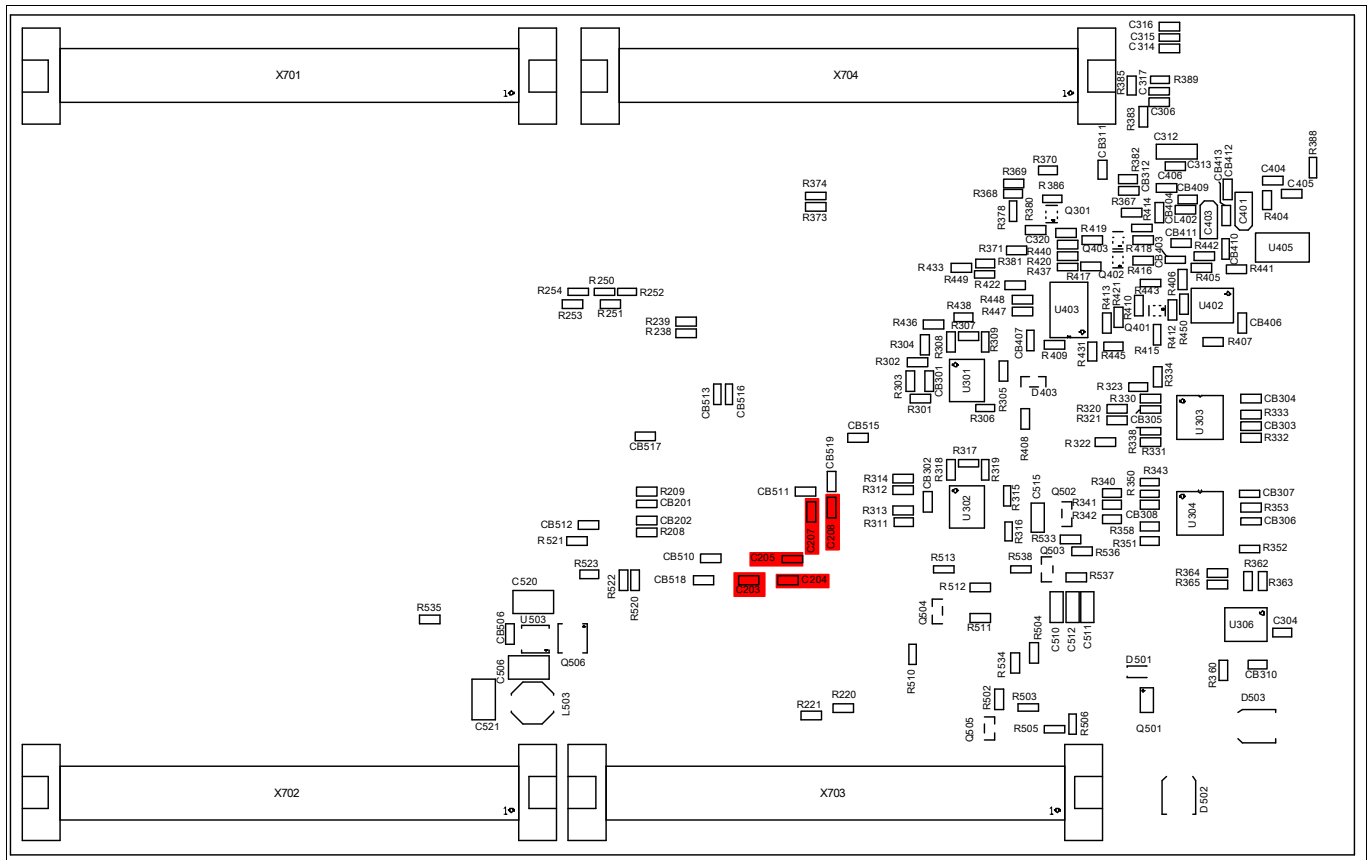

Figure 3-6 Filter components of ADC channels on Bottom Side

3.14 Other peripherals

For all other peripherals there are no special plugs on the board. The peripheral signals are available on the different connectors. See [“Connector Pin Assignment” on Page 6-1](#).

3.15 Toggle LED’s

The status LED’s are low active and can be controlled by Software.

Port 20 pin 11 up to pin 14 are connected to single LED’s (D306... D309) and powered by the normal microcontroller voltage.

Port 33 pin 4 up to pin 7 are connected to single LED’s (D302... D305) and powered by the standby voltage. This means that this LED’s can be active also when the board is in standby mode and only the standby voltage available (port 33 is powered by VEVR SB pin which is connected to standby supply of TLF35584). In this case the port pins are controlled by the standby controller if available.

3.16 Buttons

On the board are three buttons.

The reset button (S501) will apply a warm power on reset to the device.

The ENA button (S502) will be used to enable/wakeup the TLF35584.

The P33.11 button (S202) can be used by software as input. Also can this button used by the standby controller to react on an event when only standby supply is available (e.g. wakeup the TLF35584 via P33.10).

TriBoard Information

3.17 Debug System

3.17.1 OCDS1

The OCDS1 signals are connected to the IDC16 plug (X401). They work with the port supply of Microcontroller (+5V default or +3,3V). For pinout of the connector see [Figure 6-10](#). You can connect any debugger to this connector.

The signals /BRKIN and /BRKOUT are not connected per default. If you need this signals in the connector then assemble R424 and R425 or R426 with a 0R resistor.

If you connect a debug hardware make sure that the miniWiggler JDS (see [“miniWiggler JDS” on Page 3-4](#)) is not activ (ACTIV LED is off) and on the DAP connector (X402) is no hardware connected or the hardware is tristated.

If the ACTIV LED is on, then stop the active DAS Server 'UDAS' and/or remove the USB connection to the PC.

If R214 up to R216 not assembled then the connector is not usable.

3.17.2 DAP

The board comes with a DAP connector (X402). For pinout of this connector see [Figure 6-11](#). You can connect a DAP hardware here. If you use this connector make sure that the miniWiggler JDS is not activ (ACTIV LED is off) and a connected OCDS1 hardware is disconnected or tristated.

3.17.3 DAP_SCR

Additional DAP connector (X406) is connected to DAP_SCR. This DAP can be used as private DAP connection to the standby controller. For pinout of this connector see [Figure 6-15](#). You can connect a DAP hardware here. This DAP use P33.6 and P33.7 which are connected to LED on the board. Maybe it is necessary to remove R393 and R394 if the speed of the connection is not fast enough.

3.17.4 High speed with DAP

For use the DAP connection with 160 MHz you need to remove 3 resistors to have a very short connection between device and connector. On the TC3X4L Triboard this 3 resistors are R214, R215 and R216 for DAP (red marked in [Figure 3-7](#)). This resistors needs to be removed.

Important: When the resistors are removed then only the DAP connector on the board can be used. The on board wiggler and the OCDS1 connector couldn't be use (are disconnected) in this case, also the DAP/JTAG part of the ETK connector couldn't be used.

All resistors are red marked in the following figure:

TriBoard Information

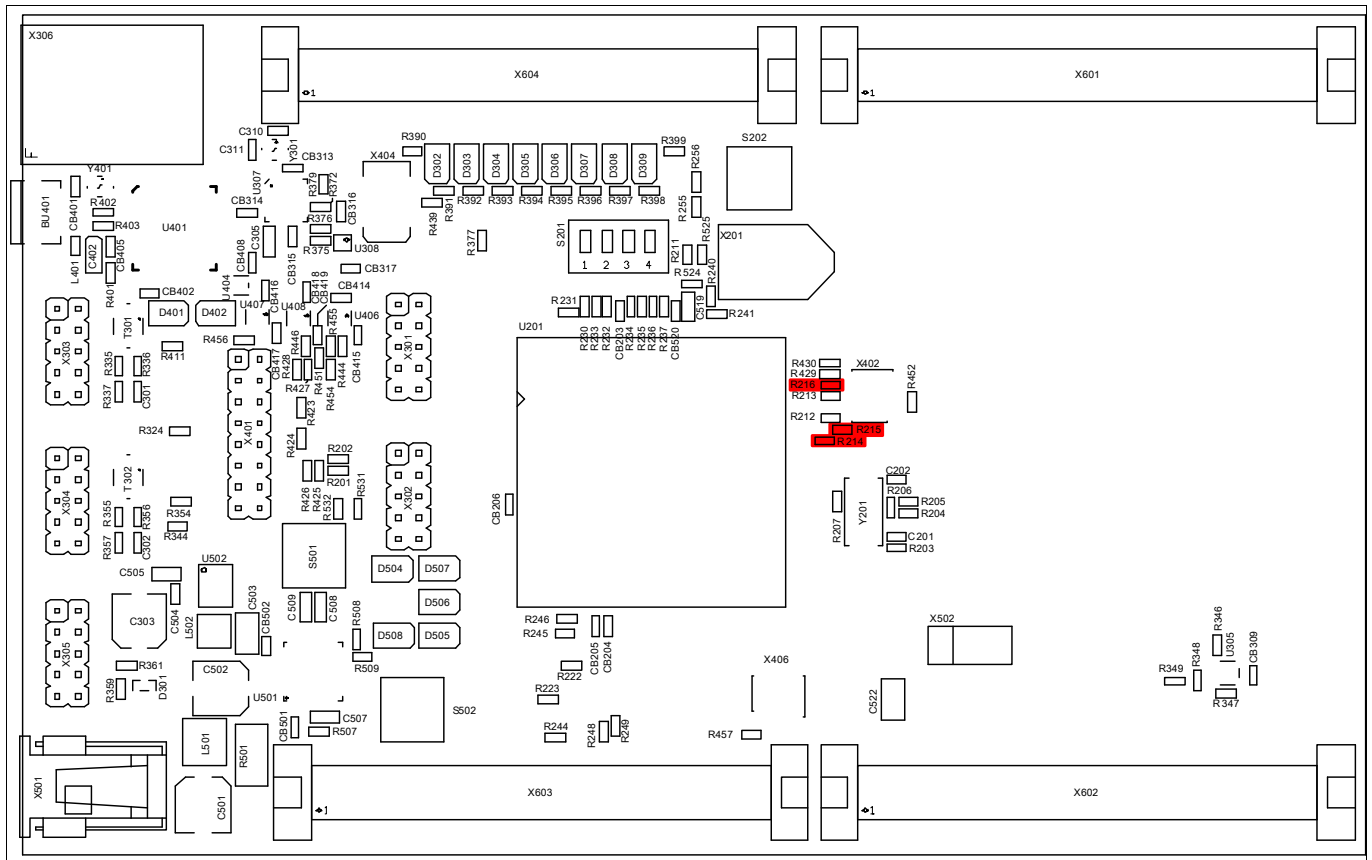

Figure 3-7 Location of DAP resistors on Top Side

3.17.5 ETK connector (optional)

The TriBoard provide a 10 pin samtec connector (X404) for connecting to an ETK. This connector should be assembled by your self if needed.

For the pinout of connector see Figure 6-12.

The needed Samtec connector is: TFM-105-02-A.

3.17.6 EmW Power (optional)

The TriBoard provide the 4 pin power connector (X502) for the Ethernet miniWiggler (EmW). This connector should be assembled by your self if needed.

For the pinout of connector see Figure 6-13.

The needed Samtec connector is the JST B4B-PH-K.

The connector provide the input voltage to the Ethernet miniWiggler and an enable/wakeup signal connected to TLF35584 and a standby voltage of +1,25V connected to VDDSB of device. In case the EmW is used you must remove R522. If R522 is removed then you must make sure that the EmW is always connected. Otherwise with assembled R522 (default) you should not connect the pin 4 of connector.

The mentioned resistor is red marked in Figure 3-8

TriBoard Information

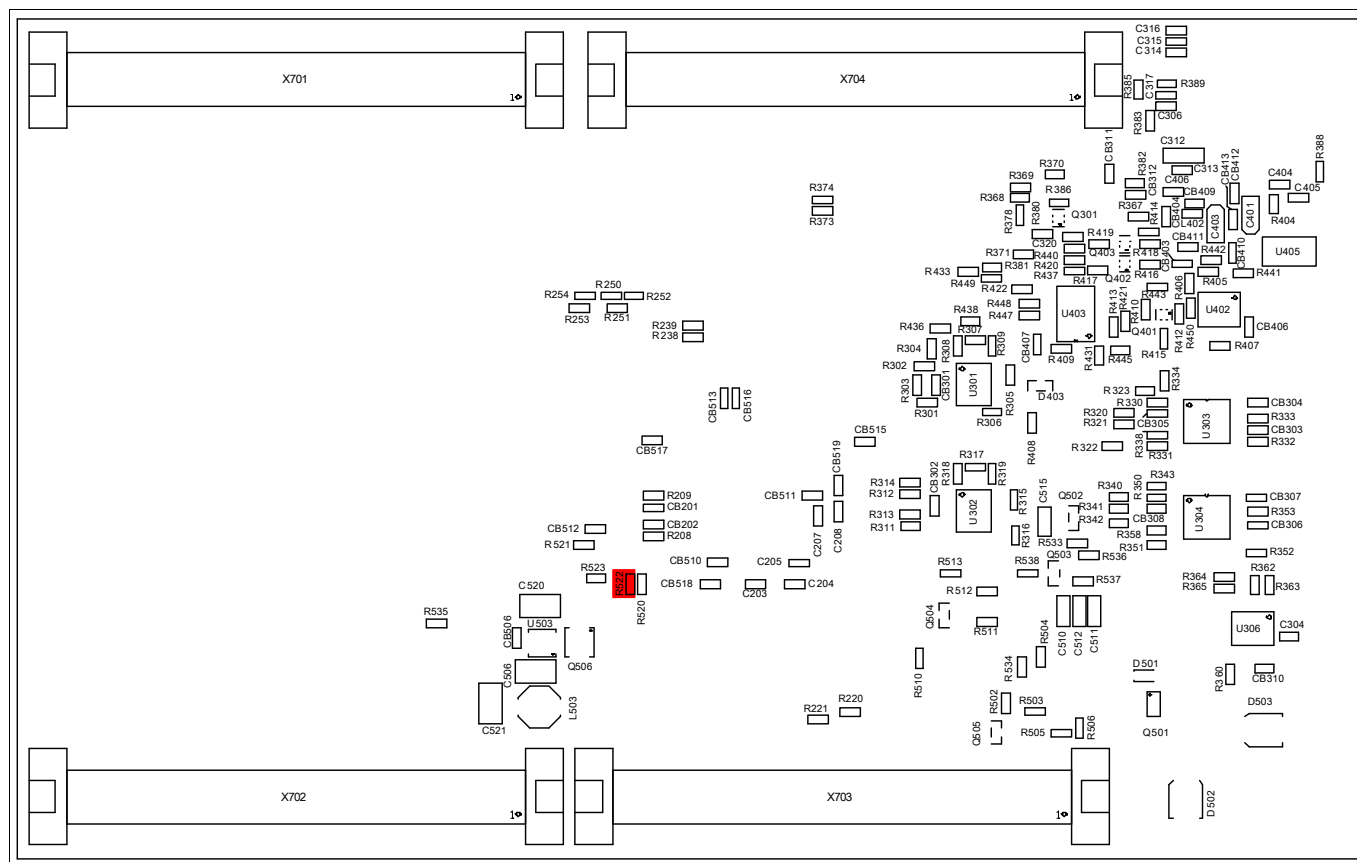

Figure 3-8 Resistor for VDDSB

TriBoard Configuration

4 TriBoard Configuration

4.1 HW Boot Configuration

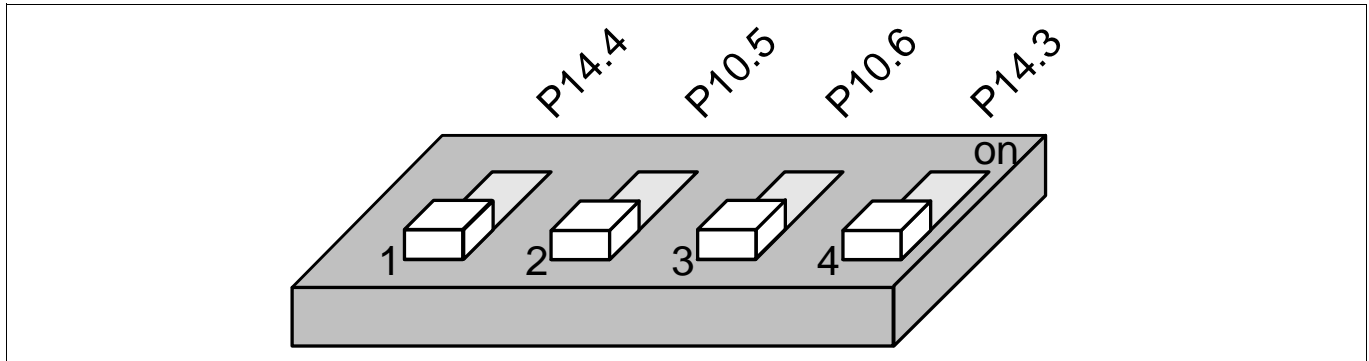

Figure 4-1 HW Configuration DIP-Switches

The picture above shows the definition of the boot HW configuration switch. The meaning of the switches will be described in the following table (Table 4-1).

Note: The ON position of the switch is equal to a logical LOW at the dedicated pin.

4.1.1 Default Pad State

P14.4 / HWCFG6 is used to select the Default Pad State. Dipswitch 1 used to select this.

In case that dipswitch1 is set to ON then all I/O pins are in tristate otherwise the internal pull-up devices are enabled on the I/O pins. Please note that after change Dipswitch 1 you must make a power cycle (switch off -> switch on) to use the new configuration.

In case that TriState is selected (Dipswitch 1 is set to ON) then the I/O pins are floating. If you need a specific level on different pins during startup (e.g. driver pins) then you must add the needed pull device (up or down). Some pins (especially the HWCFG pins) haven always the needed external pull-up and/or pull-down resistor assembled on the board.

4.1.2 Bootmode

Table 4-1 User Startup Modes ¹⁾²⁾³⁾

HWCFG[5...3]	Type of Boot	2	3	4
XX1	Start-up mode is selected by Boot Mode Index	X	X	OFF
110	Internal Start from Flash	OFF	OFF	ON
100	Alternate Boot Mode, Generic Bootstrap Loader on fail (P14.0/P14.1)	ON	OFF	ON
010	Alternate Boot Mode, ASC Bootstrap Loader on fail (P15.2/P15.3)	OFF	ON	ON
000	Generic Bootstrap Loader (P14.0/P14.1)	ON	ON	ON

1) The shadowed line indicates the default setting.

2) 'x' represents the don't care state.

3) 2 to 4 are the Dip Switch numbers.

TriBoard Configuration

4.2 Assembly Options

4.2.1 General optional resistors

Table 4-2 General optional resistors (default assembly in brackets)

Component	Description
R202	Connect P20.2 (/TESTMODE) to GND (not assembled)
R203	XTAL1 Rload (50 Ohm) (not assembled)
R206	XTAL Rparallel (not assembled)
R207	XTAL2 Rserial (assembled)
R238	Switch off EVRC (not assembled)
R240	Switch off EVR33 (not assembled)
R390	Connect V_STBY to toggle LEDs D302...D305 (assembled)
R399	Connect V_UC to toggle LEDs D306...D309 (assembled)
R423	Connect P20.0 with miniWiggler JDS (not assembled)
R424	Connect P20.0 with OCDS1 connector (not assembled)
R425	Connect P21.7 with OCDS1 connector (not assembled)
R426	Connect P20.2 with OCDS1 connector (not assembled)
R427	Connect P21.7 with USR1 of miniWiggler JDS (not assembled)
R428	Connect P20.2 with USR1 of miniWiggler JDS (not assembled)
R429	Connect P21.6 (DAP3) with USR1 of DAP (assembled)
R430	Connect P20.2 with USR1 of DAP (not assembled)
R433	Connect P21.7 with ETK connector (not assembled)
R439	Connect P21.7 with ETK connector (not assembled)
R508	Connect pin MPS of TLF35584 to V_CO (not assembled)
R509	Connect pin MPS of TLF35584 to Ground (assembled)
R524	Connect VDDP3 to V_UC (not assembled)
R525	Connect VDDP3 to +3V3 (not assembled)

Note: All resistors are red marked in the following figures

TriBoard Configuration

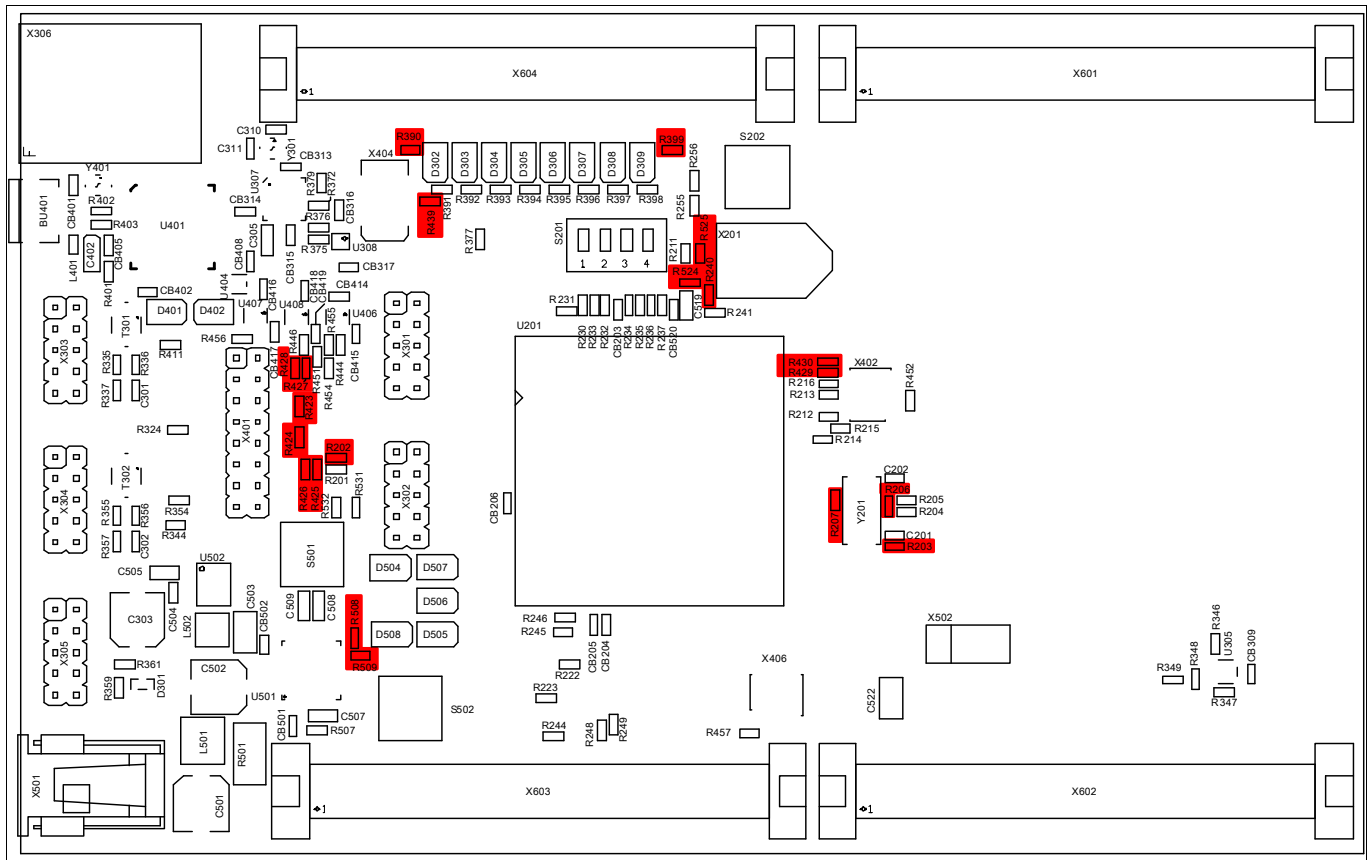

Figure 4-2 Location of general optional resistors on Top Side

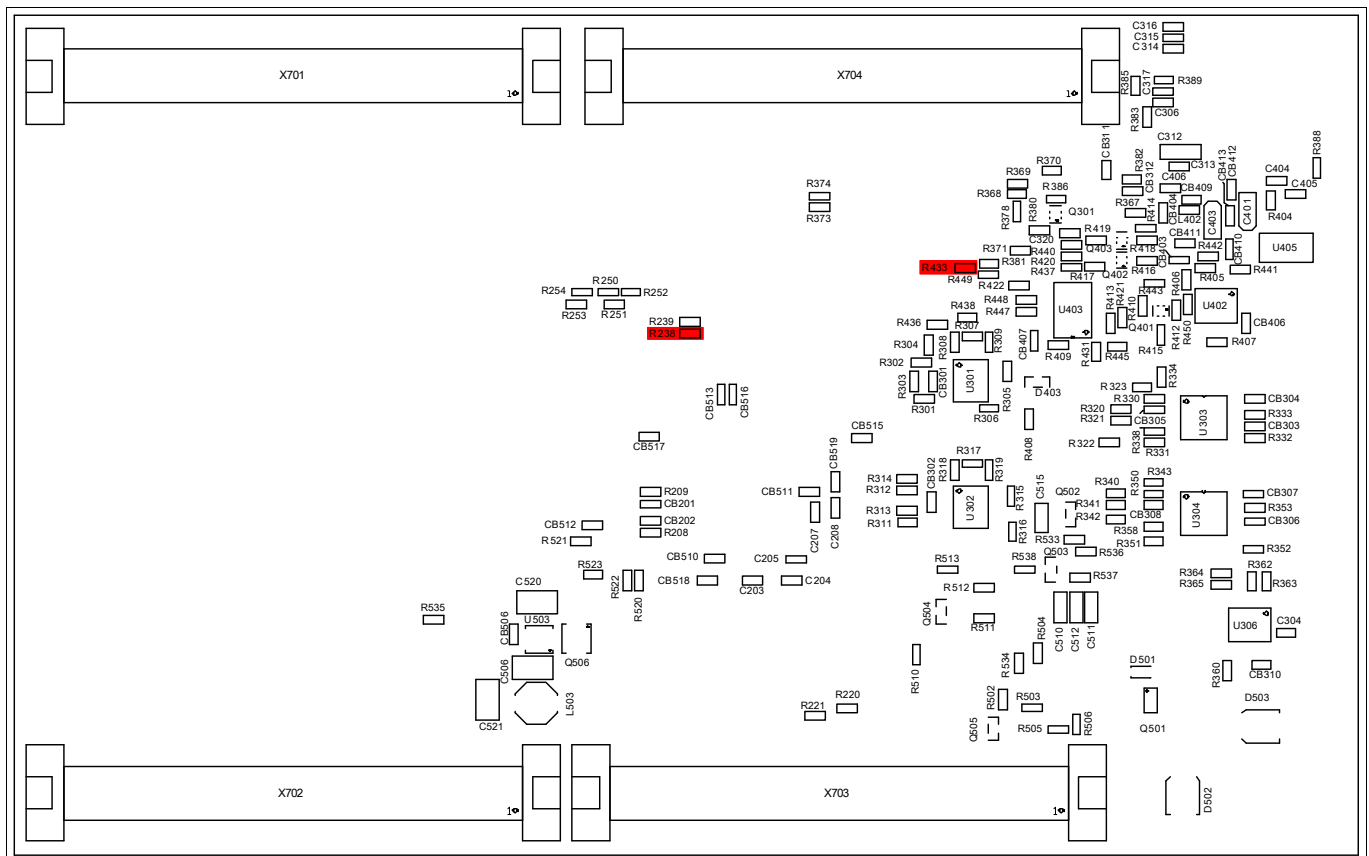

Figure 4-3 Location of general optional resistors on Bottom Side

TriBoard Configuration

4.2.2 Resistors for peripherals

Table 4-3 Resistors for peripherals (default assembly in brackets)

Component	Description
R220	Connect V_VR with VDDM (assembled)
R221	Connect +3V3 with VDDM (not assembled)
R222	Connect VAREF1 with VDDM (assembled)
R223	Connect VAREF2/AN43 with VDDM (assembled)
R301	Connect P20.7 with RXD of CAN0 transceiver (assembled)
R302	Connect P20.8 with TXD of CAN0 transceiver (assembled)
R303	Connect P14.1 with RXD of CAN0 transceiver (not assembled)
R304	Connect P14.0 with TXD of CAN0 transceiver (not assembled)
R311	Connect P13.1 with RXD of CAN1 transceiver (assembled)
R312	Connect P13.0 with TXD of CAN1 transceiver (assembled)
R313	Connect P00.1 with RXD of CAN1 transceiver (not assembled)
R314	Connect P00.0 with TXD of CAN1 transceiver (not assembled)
R320	Connect P02.0 with TXD of ERAY-A transceiver (assembled)
R321	Connect P02.4 with TXDEN of ERAY-A transceiver (assembled)
R322	Connect P02.1 with RXD of ERAY-A transceiver (assembled)
R323	Connect P10.1 with EN of ERAY-A transceiver (assembled)
R324	Connect P10.2 with ERRN of ERAY-A transceiver (assembled)
R340	Connect P02.2 with TXD of ERAY-B transceiver (assembled)
R341	Connect P02.5 with TXDEN of ERAY-B transceiver (assembled)
R342	Connect P02.3 with RXD of ERAY-B transceiver (assembled)
R343	Connect P20.10 with EN of ERAY-B transceiver (assembled)
R344	Connect P20.9 with ERRN of ERAY-B transceiver (assembled)
R348	Connect P15.4 with SCL of I2C Eeprom (assembled)
R349	Connect P15.5 with SDA of I2C Eeprom (assembled)
R364	Connect P15.1 with RXD of LIN1 transceiver (assembled)
R365	Connect P15.0 with TXD of LIN1 transceiver (assembled)
R368	Connect P11.9 with RXD1 of Ethernet PHY (assembled)
R369	Connect P11.10 with RXD0 of Ethernet PHY (assembled)
R370	Connect P11.11 with CRS_V of Ethernet PHY (assembled)
R371	Connect P11.12 with RXC and TXC of Ethernet PHY (assembled)
R372	Connect P11.6 with TXEN of Ethernet PHY (assembled)
R373	Connect P11.3 with TXD0 of Ethernet PHY (assembled)
R374	Connect P11.2 with TXD1 of Ethernet PHY (assembled)
R376	Disable outputs of MDIO/MDC transceiver (not assembled)
R377	Connect P10.3 with MDINT of Ethernet PHY (not assembled)
R436	Connect P14.0 with RXD of USB to UART (assembled)

TriBoard Configuration

Table 4-3 Resistors for peripherals (default assembly in brackets) (continued)

Component	Description
R437	Connect P14.1 with TXD of USB to UART (assembled)
R438	Connect P15.2 with RXD of USB to UART (not assembled)
R440	Connect P15.3 with TXD of USB to UART (not assembled)

Note: All resistors are red marked in the following figures

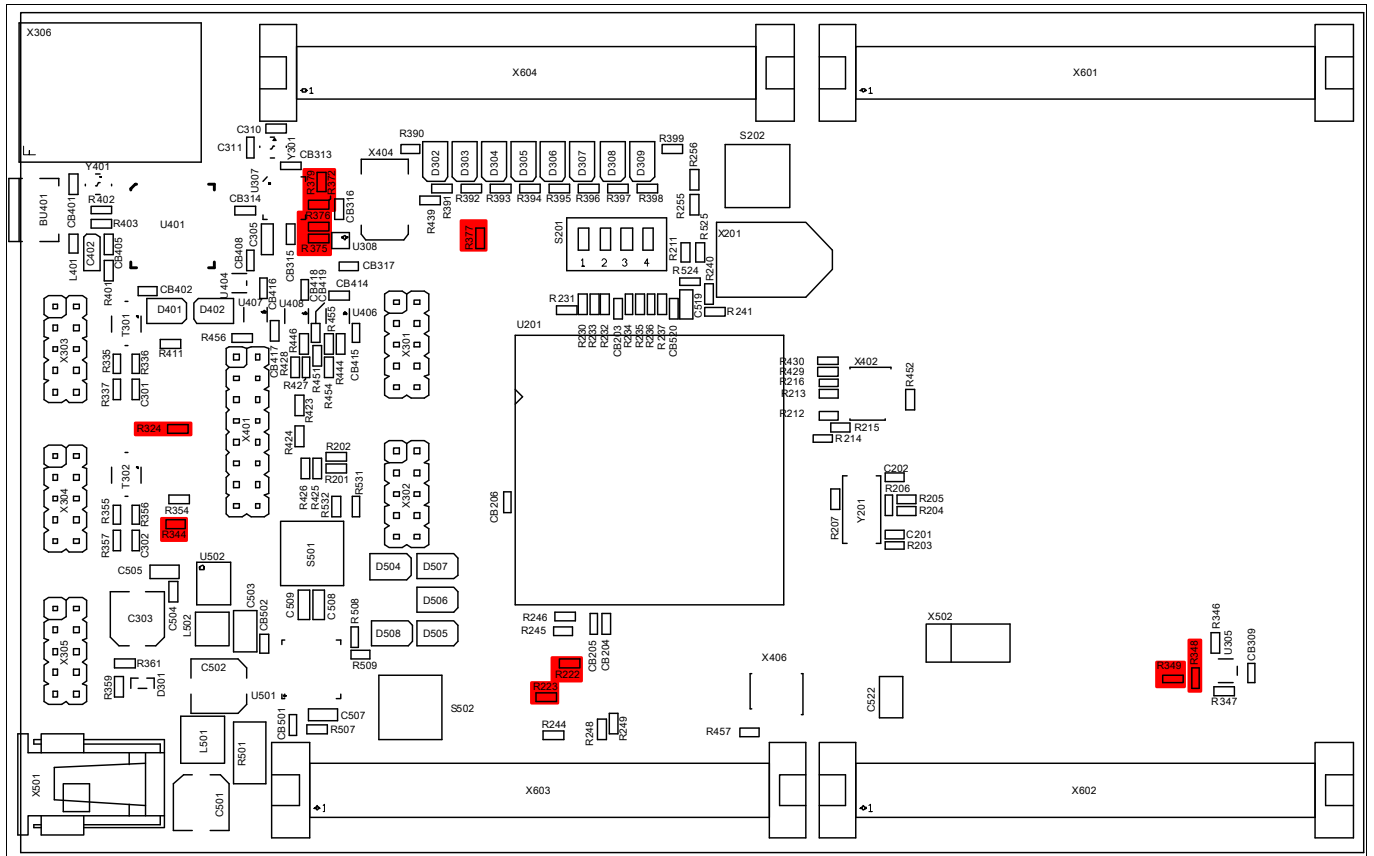

Figure 4-4 Location of peripheral resistors on Top Side

TriBoard Configuration

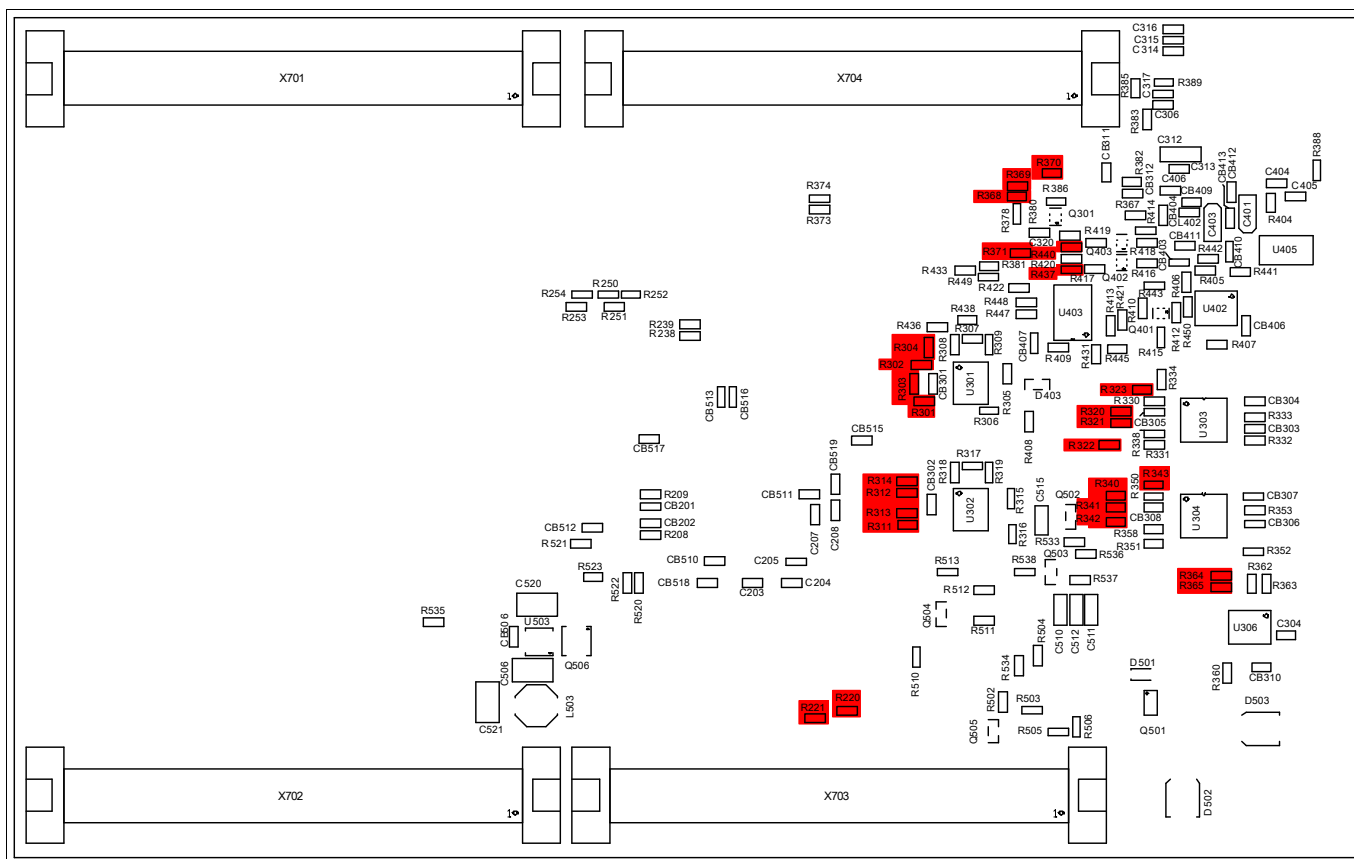

Figure 4-5 Location of peripheral resistors on Bottom Side

Signal (on board used) Description

5 Signal (on board used) Description

For more information about the signals please see the user manual/datasheet for TC3X4 and/or the schematics of the board.

All not mentioned signals are not used on the board and can be used outside. Optional marked signals are used only if they are connected (default is that they are not used on the board).

5.1 Power Signals

Table 5-1 Power Signals

Short name	Description
VCC_IN	Supply Input (3,5V...40V)
VIN	Input Voltage of Power Supply Device
GND	Ground
V_PREPEG	Pre Regulator Voltage (~5,8V)
V_UC	Microcontroller Supply Voltage (5V or 3,3V depends on assembled TLF35584)
V_CO	Communication Supply Voltage (5V)
V_VR	Reference Supply Voltage (5V)
V_STBY	Standby Supply Voltage (5V or 3,3V depends on assembled TLF35584)
VDD	Core Supply Voltage (1,25V)
VDDSB	Emulation Stand-by SRAM Supply Voltage (1,25V)
VDDP3	Flash Power Supply Voltage (3,3V)
VFLEX	Flexport Supply Voltage (3,3V)
VEXTOSC	Oscillator Port Supply Voltage (5V or 3,3V depends on assembled TLF35584)
VDDOSC	Oscillator Core Supply Voltage (1,25V)
VSSOSC	Oscillator Ground
VDDM	ADC Analog Part Supply Voltage (5V or 3,3V selectable via 0R resistors)
VAREF1	ADC Reference Voltage 1 (VDDM)
VAREF2	ADC Reference Voltage 2 (VDDM)
VDD_USB	Supply Voltage from USB (5V)
VDD_FT	Supply Voltage FT2232HL device (3,3V)

5.2 Reset Signals

Table 5-2 Reset Signals

Short name	Description
/PORST	Power On Reset
/DBG_PORST	Power On Reset from debug connectors
/ESR0	External Service Request 0 (Hardware Reset)
/ESR1	External Service Request 1 (Non Maskable Interrupt)

Signal (on board used) Description

5.3 Config Signals

Table 5-3 Config Signals

Short name	Description
P14.5	HWCFG1 (EVR33OFF / EVR33ON)
P14.2	HWCFG2 (EVRCOFF / EVRCON)
P14.4	HWCFG6 (Pins in tristate / Pins with pull-up)
P14.3	HWCFG3 (Boot from pins / Boot from Flash BMI)
P10.5	HWCFG4 (see boot configuration Table 4-1)
P10.6	HWCFG5 (see boot configuration Table 4-1)

5.4 Clock Signals

Table 5-4 Clock Signals

Short name	Description
XTAL1	Crystal Oscillator Input
XTAL2	Crystal Oscillator Output

5.5 Debug Signals

Table 5-5 Debug Signals

Short name	Description
/TRST	Test Reset
DAP0	Device Access Port Line 0 / Test Data Clock (TCK)
DAP1	Device Access Port Line 1 / Test Data Select (TMS)
DAP2	Device Access Port Line 2 / Test Data Output (TDO)
P21.6	Test Data Input (TDI)
DAP0_A	DAP0 / TCK from debug connectors
DAP1_A	DAP1 / TMS from debug connectors
P21.7	DAP2 / TDO from debug connectors / TriCore Breakpoint Input
P20.2	Test Mode Select Input
P20.0	TriCore Breakpoint Output

5.6 Peripheral Signals

Table 5-6 Peripheral Signals

Short name	Description
P14.1	ASCLIN0 Receive Input A CAN01 Receive Input B (optional)
P14.0	ASCLIN0 Transmit Output CAN01 Transmit Output (optional)
P15.3	ASCLIN0 Receive Input B (optional)

Signal (on board used) Description

Table 5-6 Peripheral Signals (continued)

Short name	Description
P15.1	ASCLIN1 Receive Input A
P15.0	ASCLIN1 Transmit Output
P15.4	I2C0 Serial Clock
P15.5	I2C0 Serial Data Input C und Output
P20.7	CAN00 Receive Input B
P20.8	CAN00 Transmit Output
P13.1	CAN10 Receive Input D
P13.0	CAN10 Transmit Output
P00.1	CAN10 Receive Input A (optional)
P00.0	CAN10 Transmit Output (optional)
P02.0	E-Ray Channel A Transmit Data Output
P02.4	E-Ray Channel A Transmit Data Output enable
P02.1	E-Ray Channel A Receive Data Input 2
P10.1	E-Ray Channel A Enable Output
P10.2	E-Ray Channel A Error Input
P02.2	E-Ray Channel B Transmit Data Output
P02.5	E-Ray Channel B Transmit Data Output enable
P02.3	E-Ray Channel B Receive Data Input 2
P20.10	E-Ray Channel B Enable Output
P20.9	E-Ray Channel B Error Input
P11.2	Ethernet TXD1 Output
P11.3	Ethernet TXD0 Output
P11.6	Ethernet TXEN Output
P11.9	Ethernet RXD1 Input A
P11.10	Ethernet RXD0 Input A
P11.11	Ethernet CRSDV Input A
P11.12	Ethernet REFCLK Input A
P02.8	Ethernet Management Data Clock Output (MDC)
P00.0	Ethernet Management Data Input/Output (MDIO)
P10.3	Ethernet MD Interrupt Input (optional)
P14.6	QSPI2 Slave Select Output 2 for SCS of TLF35584
P15.8	QSPI2 Master Clock Output for SCL of TLF35584
P15.6	QSPI2 Master Transmit Output for SDI of TLF35584
P15.2	QSPI2 Master Receive Input E for SDO from TLF35584 ASCLIN0 Transmit Output (optional)
P02.7	Output for Watchdog Input of TLF35584
P33.8	SMU_FSP0 Output for Error Signal Input of TLF35584
P33.9	Input for Safe State Signal 1 from TLF35584

Signal (on board used) Description

Table 5-6 Peripheral Signals (continued)

Short name	Description
P33.10	Output for Wake/Inhibit Input of TLF35584
P20.0	HSCT System Clock
P21.2	HSCT Data Negative Input
P21.3	HSCT Data Positive Input
P21.4	HSCT Data Negative Output
P21.5	HSCT Data Positive Output
P20[11...14]	On board LED's
P33[4...7]	On board LED's (standby voltage supplied)

6 Connector Pin Assignment

The TriBoard will be shipped with four male (plug) connectors on top layer and four female (socket) connectors on bottom layer. The default connectors are 80-pol. Board to Board connectors from Samtec:

<http://www.samtec.com>

Plug:

FTSH-140-02-L-DV-ES-A

Socket:

FLE-140-01-G-DV-A

6.1 On Board only used signals

Following port pins are only used on board and are not connected to any connector also not via resistor:

Table 6-1 On Board only used Signals

Short name	Description
P32.0	Used as VGATE1N for EVRC
P32.1	Used as VGATE1P for EVRC
P14.2	Used as HWCFG2
P14.4	Used as HWCFG6
P14.5	Used as HWCFG1

Connector Pin Assignment

6.2 TC3X4 Connector / Top View

BUS EXPANSION (X601,X701)			PERIPHERALS (X602,X702)			
GND	1	2	GND	1	2	GND
GND	3	4	GND	3	4	GND
	5	6	P21.6	5	6	VCC_IN
	7	8	P21.7	7	8	VCC_IN
	9	10		9	10	
	11	12		11	12	
	13	14		13	14	
	15	16		/ESR1	15	/ESR0
	17	18		17	18	
	19	20		GND	19	GND
	21	22		21	22	/PORST
	23	24		P10.5	23	
	25	26		25	26	
	27	28		P10.2	27	P23.1
	29	30		P13.1	29	P22.1
	31	32		P13.0	31	P22.0
	33	34		P13.3	33	P22.3
	35	36		P13.2	35	P22.2
	37	38		P20.9	37	P20.10
	39	40		P20.13	39	P00.4
	41	42		P33.5	41	P20.6
	43	44		P20.3	43	P20.2
	45	46		P00.0	45	P00.3
	47	48		P00.1	47	P00.2
	49	50	P21.2	GND	49	GND
	51	52	P21.3	XTAL1	51	P32.4
	53	54	P21.4	XTAL2	53	
	55	56	P21.5	P15.3	55	P15.5
	57	58		P15.2	57	P15.4
	59	60		P14.1	59	P15.1
	61	62		P14.0	61	P15.0
	63	64		P20.11	63	P00.12
	65	66		P20.14	65	
	67	68		P20.12	67	P00.5
	69	70		P20.7	69	P20.8
	71	72	P20.0	P15.8	71	
	73	74		73	74	P10.3
	75	76		VDDSB	75	GND
	77	78		VEXT	77	+3V3
	79	80		VEXT	79	+3V3

Figure 6-1 Connector for TC3X4 - Pinout (Part I, Top View)

Connector Pin Assignment

ADC (X603, X703)			GTM / PORTS (X604,X704)			
GND	1	2	GND	1	2	GND
GND	3	4	GND	3	4	GND
AN0	5	6	AN16	5	6	
AN1	7	8	AN17	7	8	
AN2	9	10		9	10	
AN3	11	12		11	12	
AN4	13	14	AN20	13	14	
AN5	15	16	AN21	15	16	P14.6
AN6	17	18		17	18	
AN7	19	20		19	20	
AN8	21	22	AN24	21	22	
	23	24	AN25	23	24	
AN10	25	26		25	26	P15.6
AN11	27	28		27	28	P15.7
AN12	29	30		29	30	
AN13	31	32		31	32	
	33	34		33	34	
	35	36		35	36	
GND	37	38	GND	37	38	
VDDM	39	40	VAREF1	39	40	
GND	41	42	VAREF2 / AN43	41	42	
GND	43	44	GND	43	44	
	45	46		45	46	
	47	48		47	48	
	49	50		49	50	
AN35	51	52		51	52	
AN36	53	54	AN44	53	54	
AN37	55	56	AN45	55	56	P33.8
AN38	57	58	AN46	57	58	P33.9
AN39	59	60	AN47	59	60	P33.10
GND	61	62	GND	61	62	P33.13
	63	64	P33.6	63	64	
	65	66		65	66	
	67	68	P33.4	67	68	
VEXT	69	70	+3V3	69	70	
P02.6	71	72	P00.6	71	72	
P02.7	73	74	P00.7	73	74	
P02.8	75	76	P00.8	75	76	
P33.7	77	78	P14.3	77	78	+3V3
P33.11	79	80	P33.12	79	80	+3V3

Figure 6-2 Connector for TC3X4 - Pinout (Part II, Top View)

Connector Pin Assignment

6.3 Power connector pinout

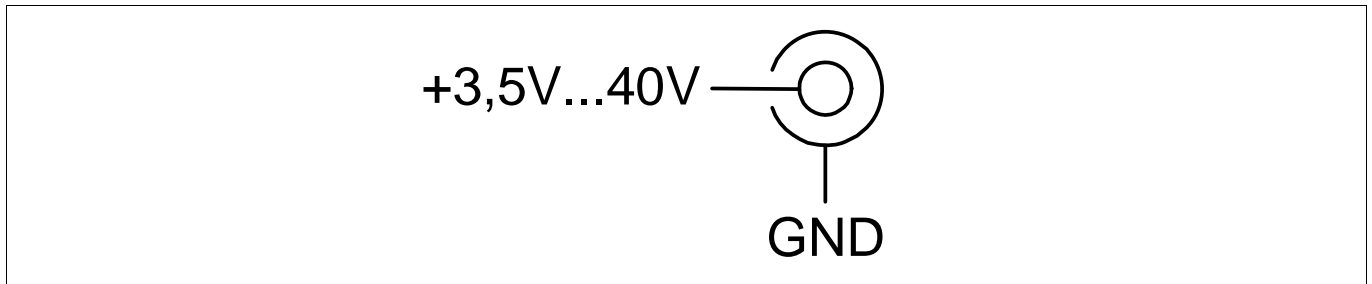

Figure 6-3 Power connector pinout (Roka 520 2550)

6.4 USB connector pinout

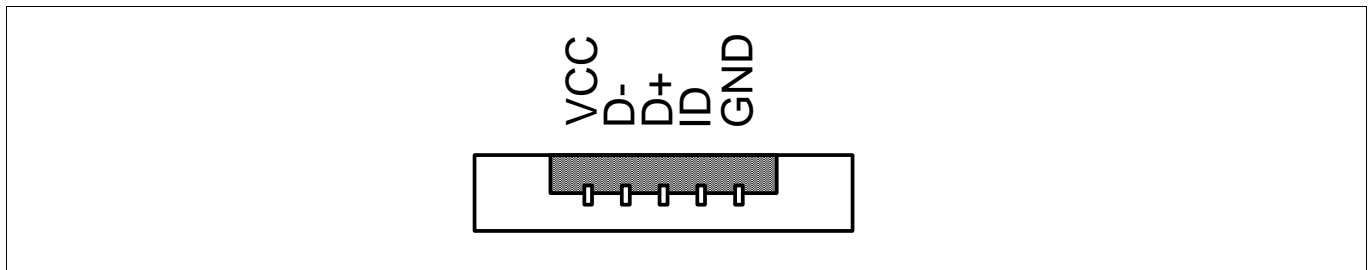

Figure 6-4 USB connector pinout (Micro USB B-type)

6.5 FlexRay™ (ERAY) connector pinout

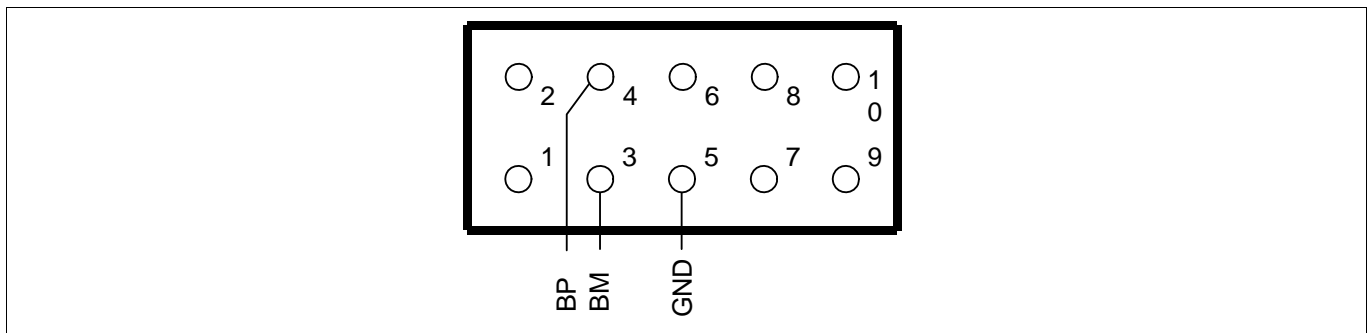

Figure 6-5 FlexRay™ (ERAY) connector pinout (IDC10)

6.6 CAN connector pinout

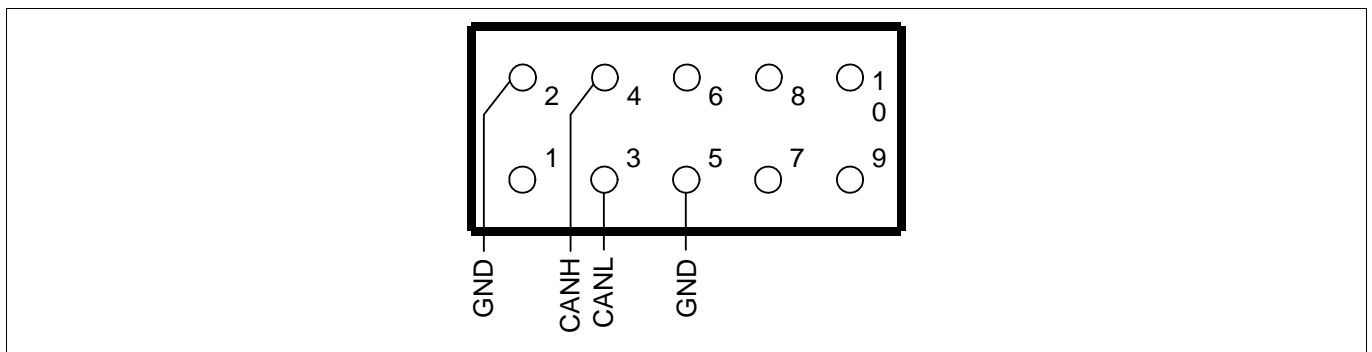

Figure 6-6 CAN connector pinout (IDC10)

Connector Pin Assignment

6.7 LIN connector pinout

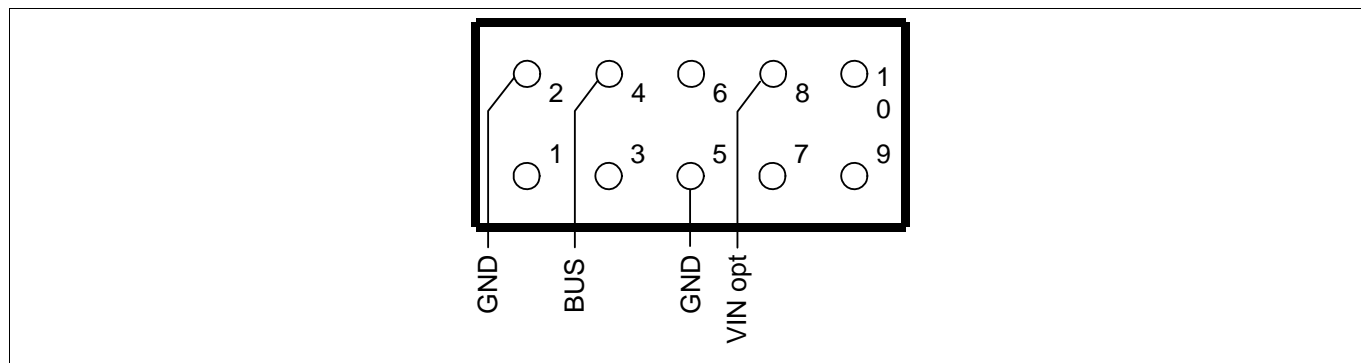

Figure 6-7 LIN connector pinout (IDC10)

6.8 HSCT connector pinout

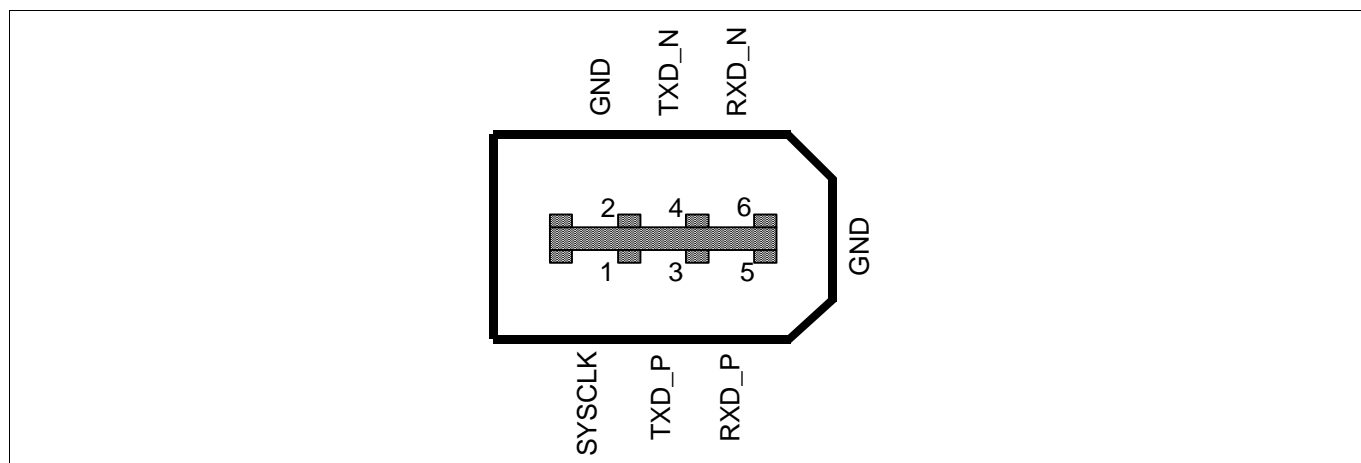

Figure 6-8 HSCT connector pinout (IEE1394 6-conductor)

6.9 Ethernet connector pinout

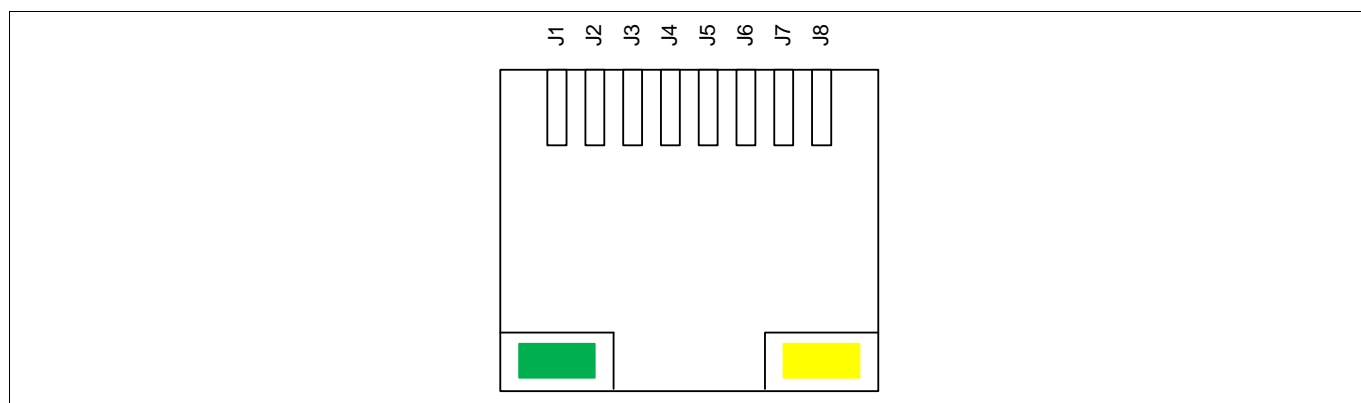

Figure 6-9 Ethernet connector pinout (RJ45)

Connector Pin Assignment

6.10 OCDS1 connector pinout

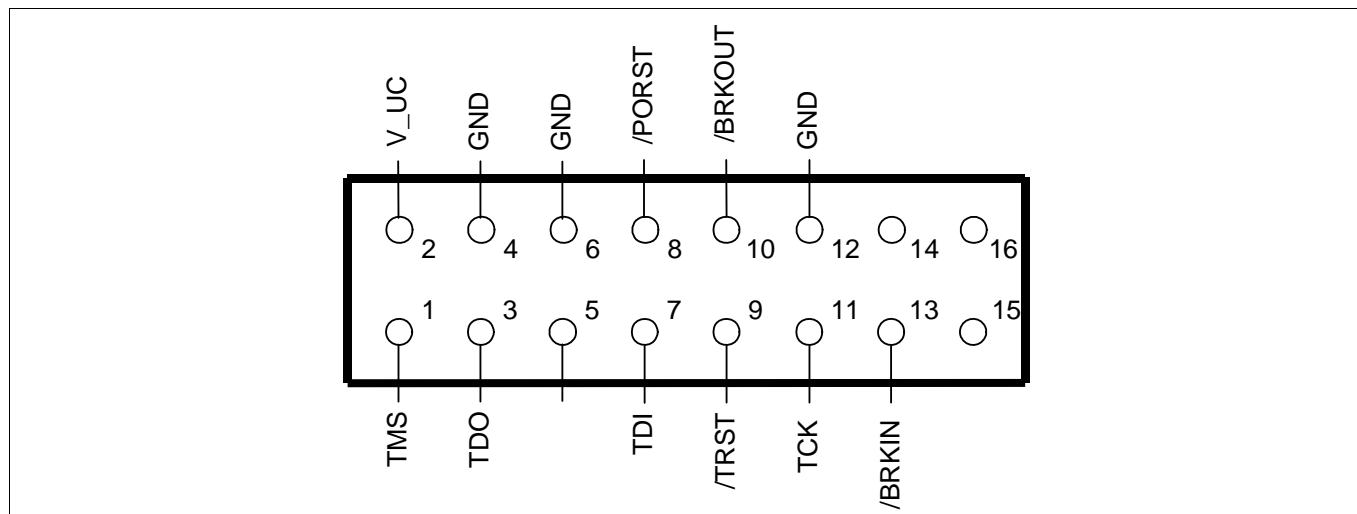

Figure 6-10 OCDS1 connector pinout (IDC16)

6.11 DAP connector pinout

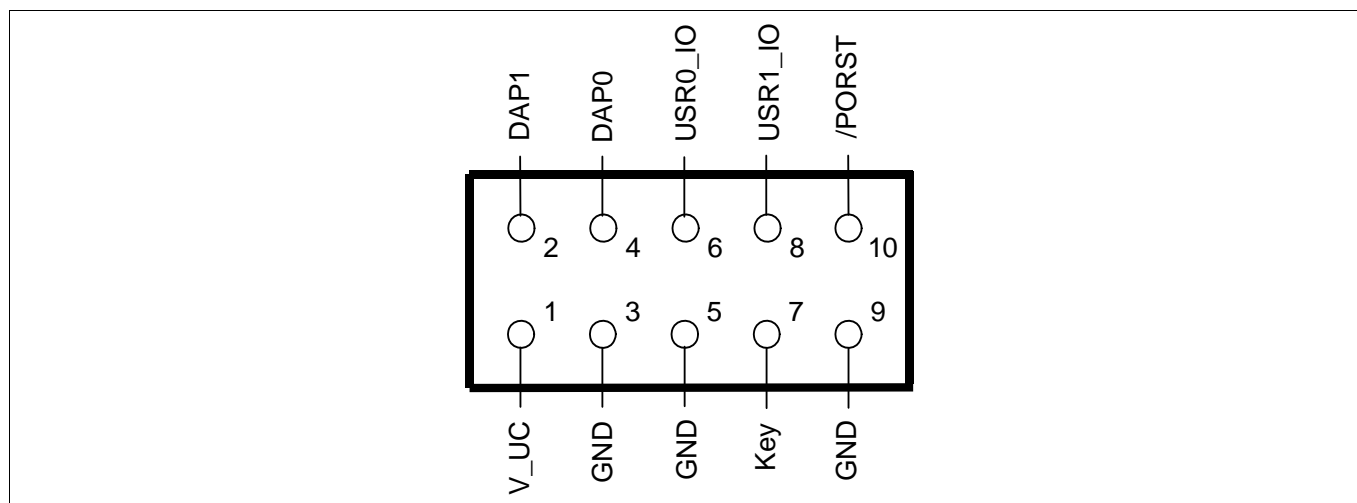

Figure 6-11 DAP connector pinout (Samtec FTSH10)

Connector Pin Assignment

6.12 ETK connector pinout

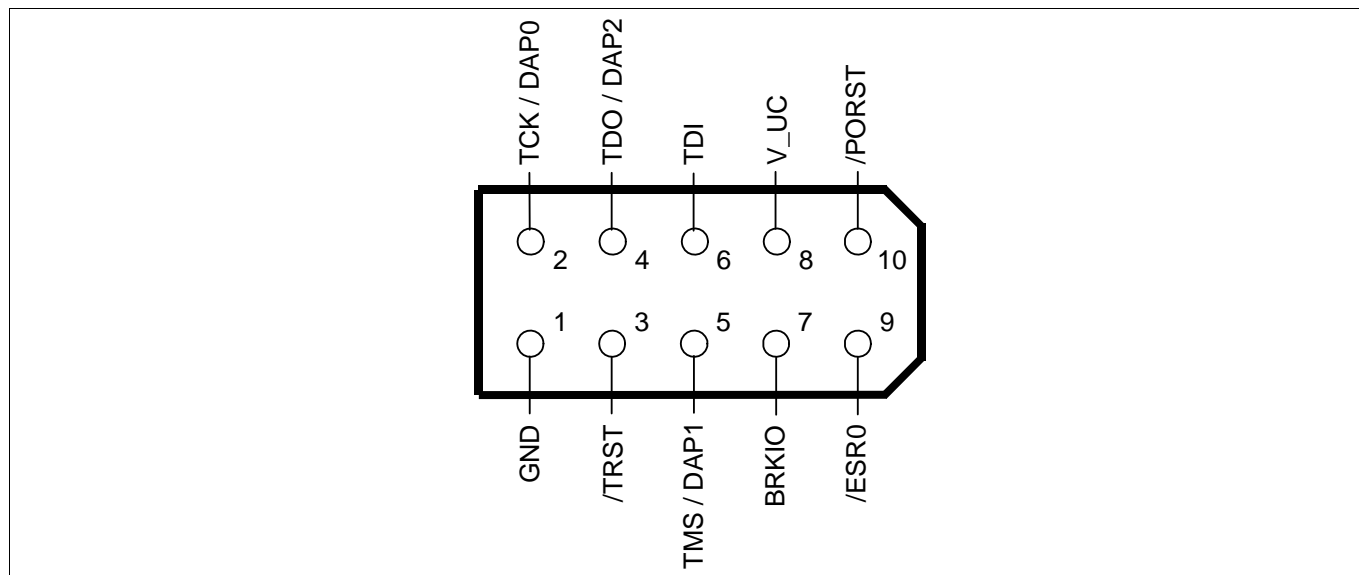

Figure 6-12 ETK connector pinout (Samtec TFM-105)

6.13 Ethernet miniWiggler power connector pinout

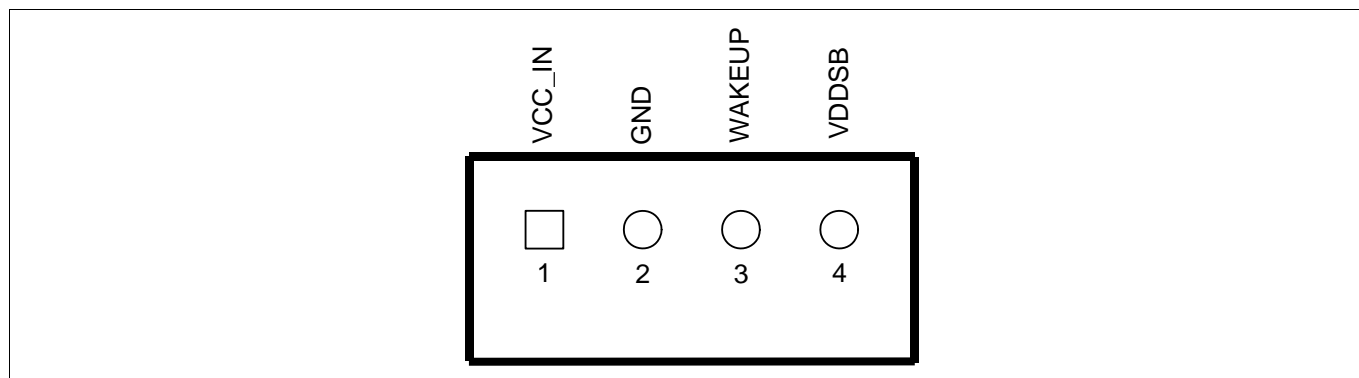

Figure 6-13 Ethernet miniWiggler connector pinout (JST B4B-PH)

7 Schematic and Layout

7.1 Known problems

7.1.1 Known problems on TriBoard TC3X4L TH V1.0

No problems known.

7.1.2 Known problems on TriBoard TC3X4L V1.0

No problems known.

7.2 Schematic

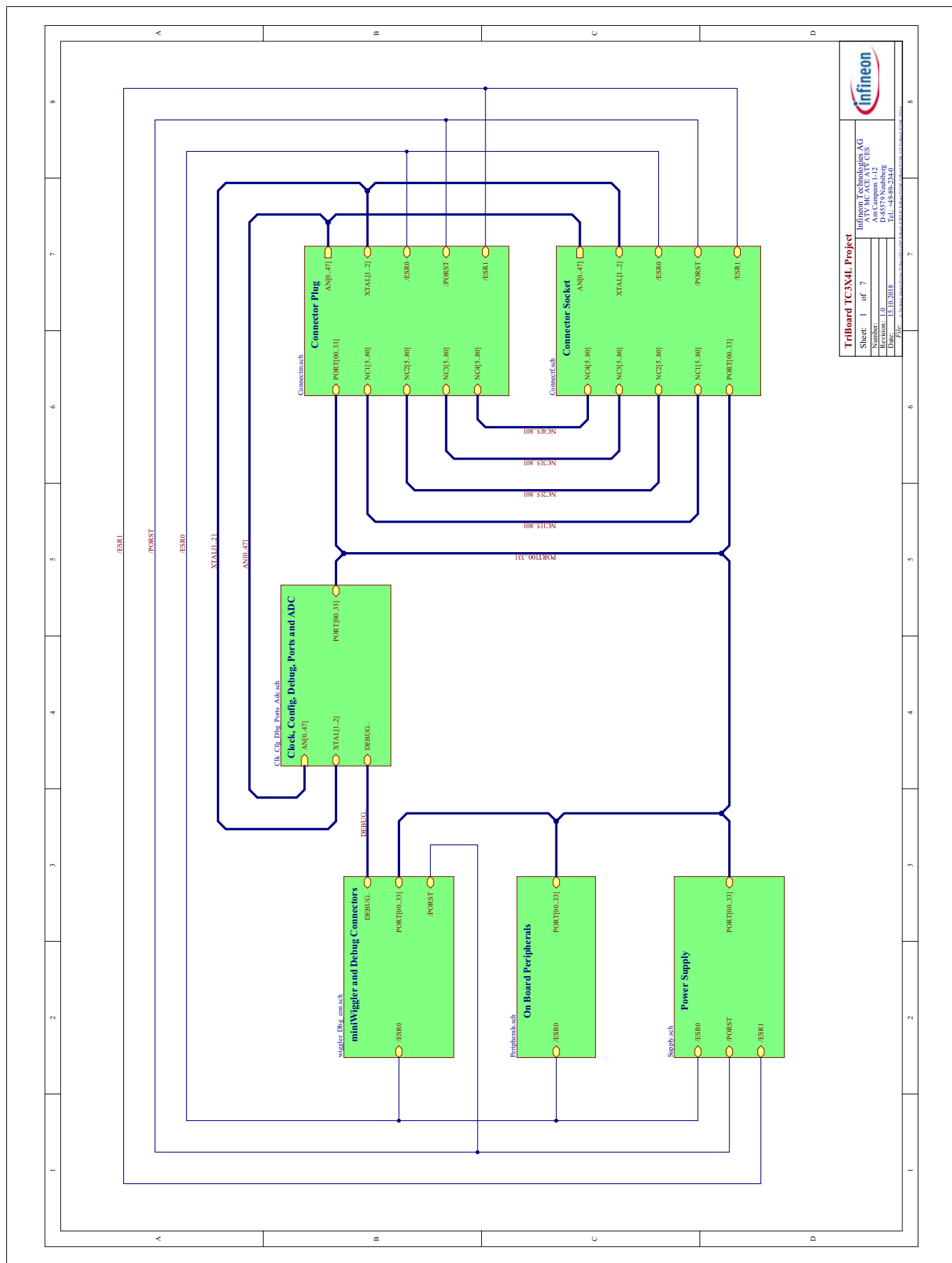

Figure 7-1 Schematic - Project

Schematic and Layout

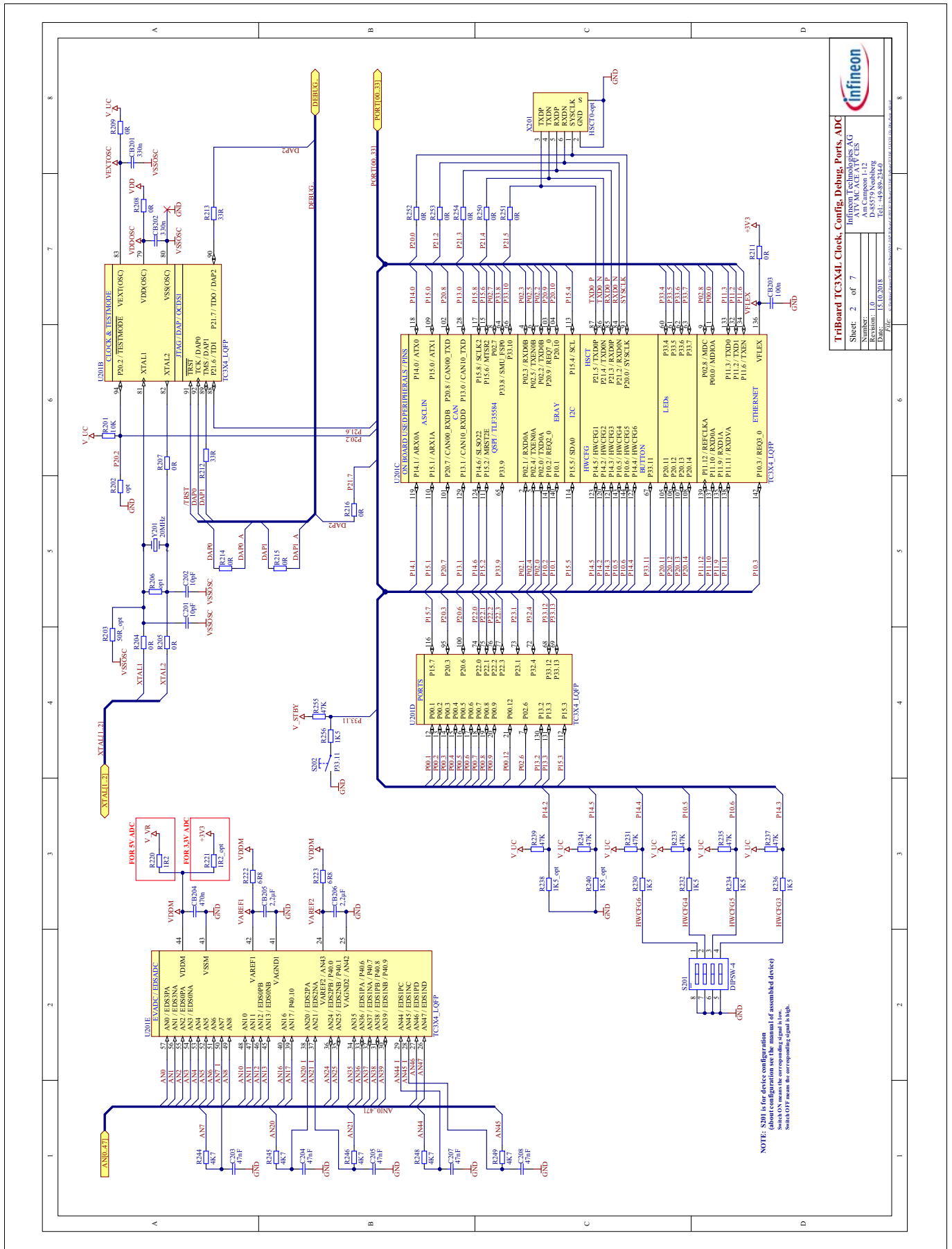

Figure 7-2 Schematic - Clock, Config, Debug, Ports and ADC

Schematic and Layout

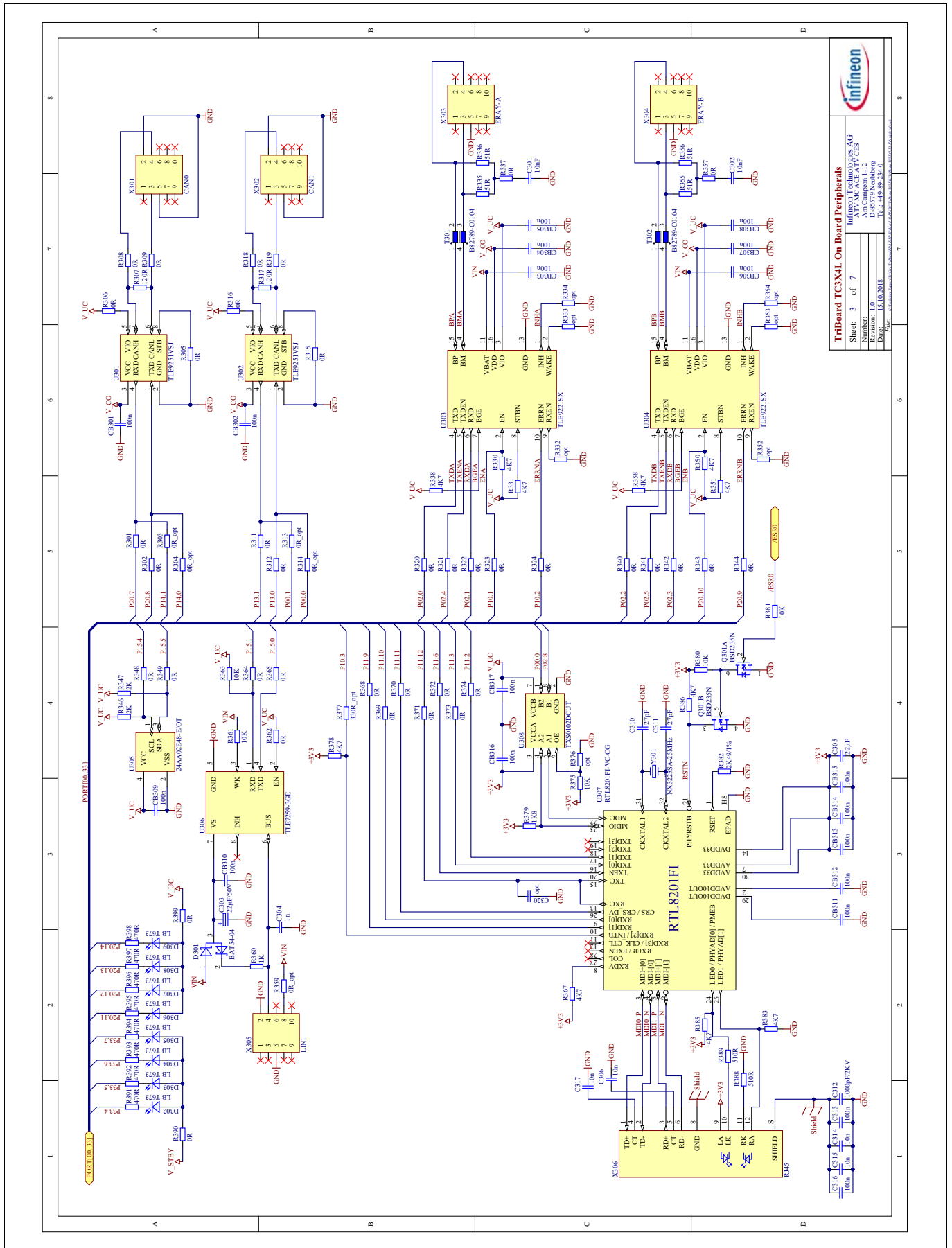
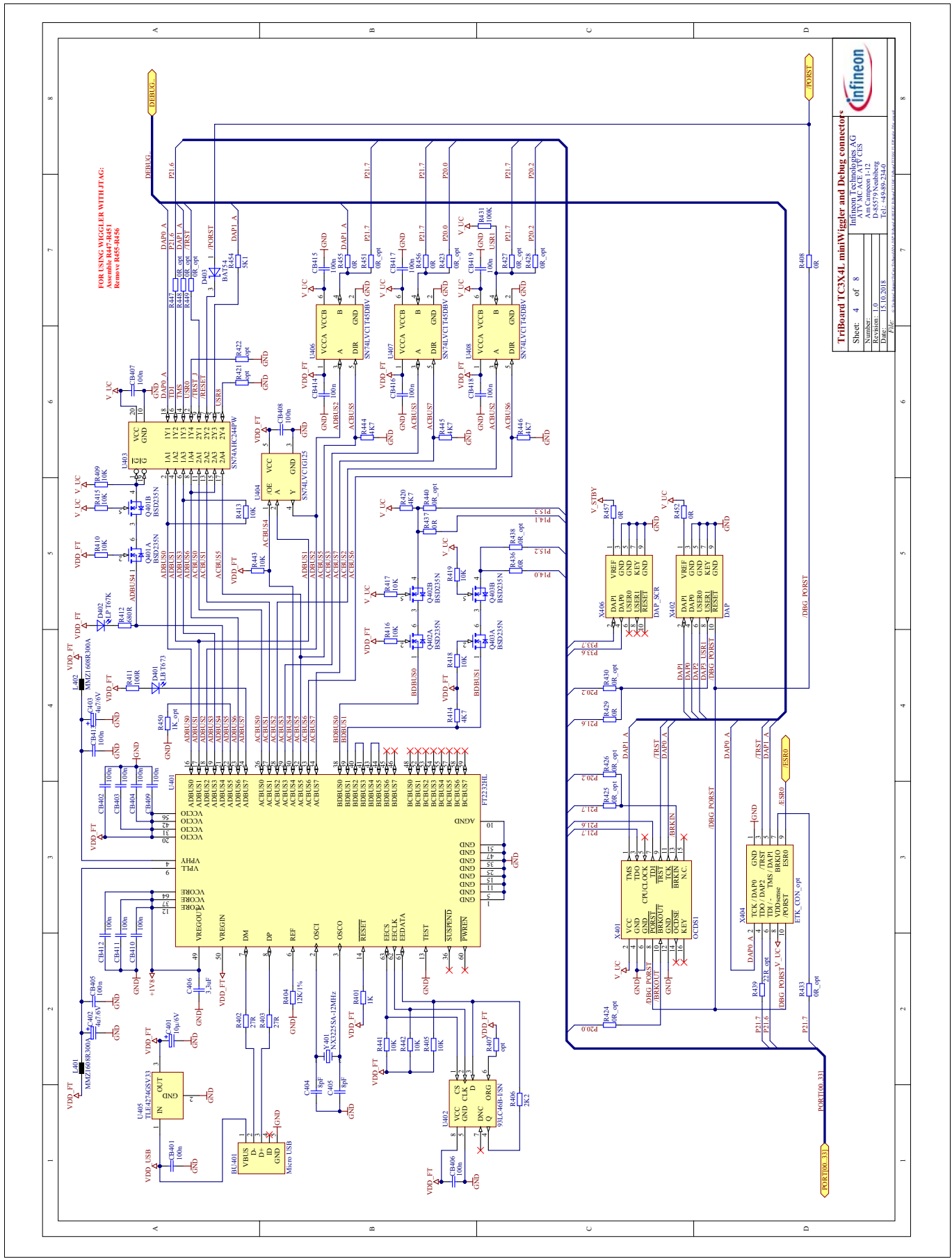
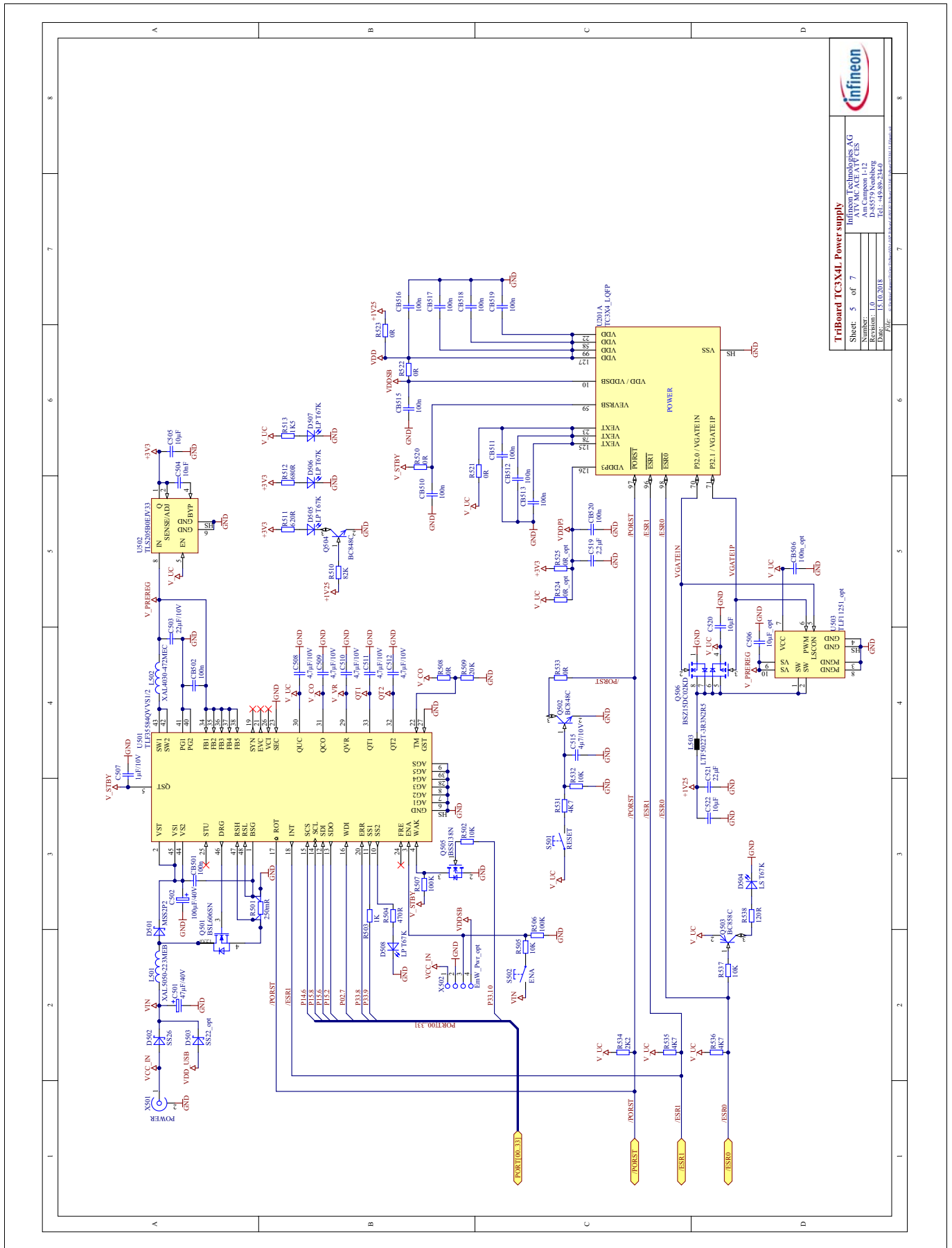

Figure 7-3 Schematic - On Board Peripherals



TriBoard TC3X4L miniWiggler and Debug connector	
Sheet:	4 of 8
File:	TC3X4L TH V1.0 / TC3X4L V1.0
Number:	1-12
Version:	1.0
Date:	15.10.2018
Author:	Amir Campion 1-12
Project:	TC3X4L TH V1.0 / TC3X4L V1.0
Contact:	Tel: +49 89 234240

Figure 7-4 Schematic - miniWiggler JDS and Debug connectors



TriBoard TC3X4L Power supply	
Sheet: 5 of 7	Infineon Technologies AG
	Am Campeon 1-12
	85049, 85050, 85051
	Postfach 10 15 53, 53115, Germany
	Date: 15.10.2018
	Tel: +49 489 234 24 0
	Fax: +49 489 234 24 20

Figure 7-5 Schematic - Power Supply

Schematic and Layout

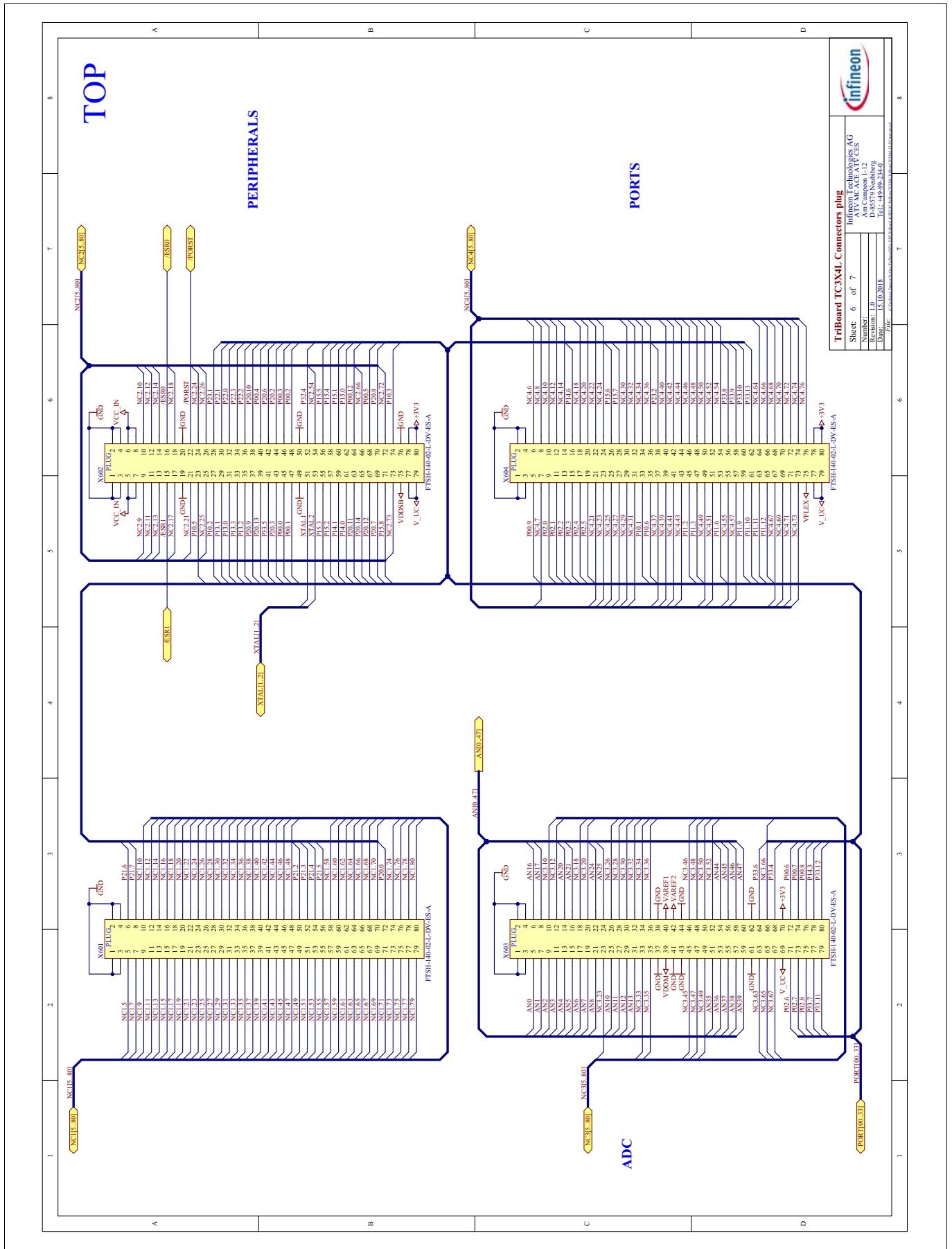

Figure 7-6 Schematic - Connectors (Plug)

Schematic and Layout

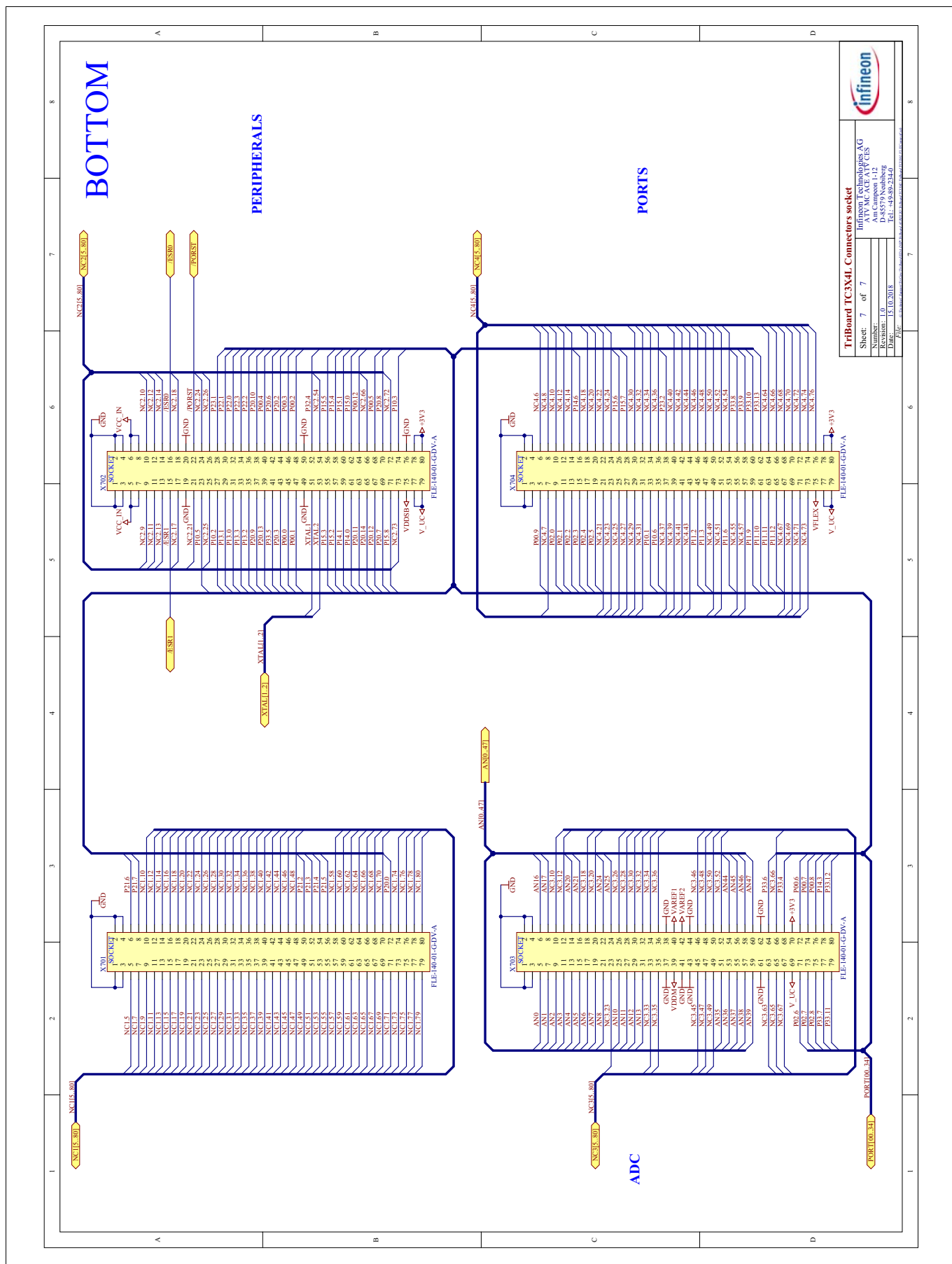

Figure 7-7 Schematic - Connectors (Socket)

7.3 Layout

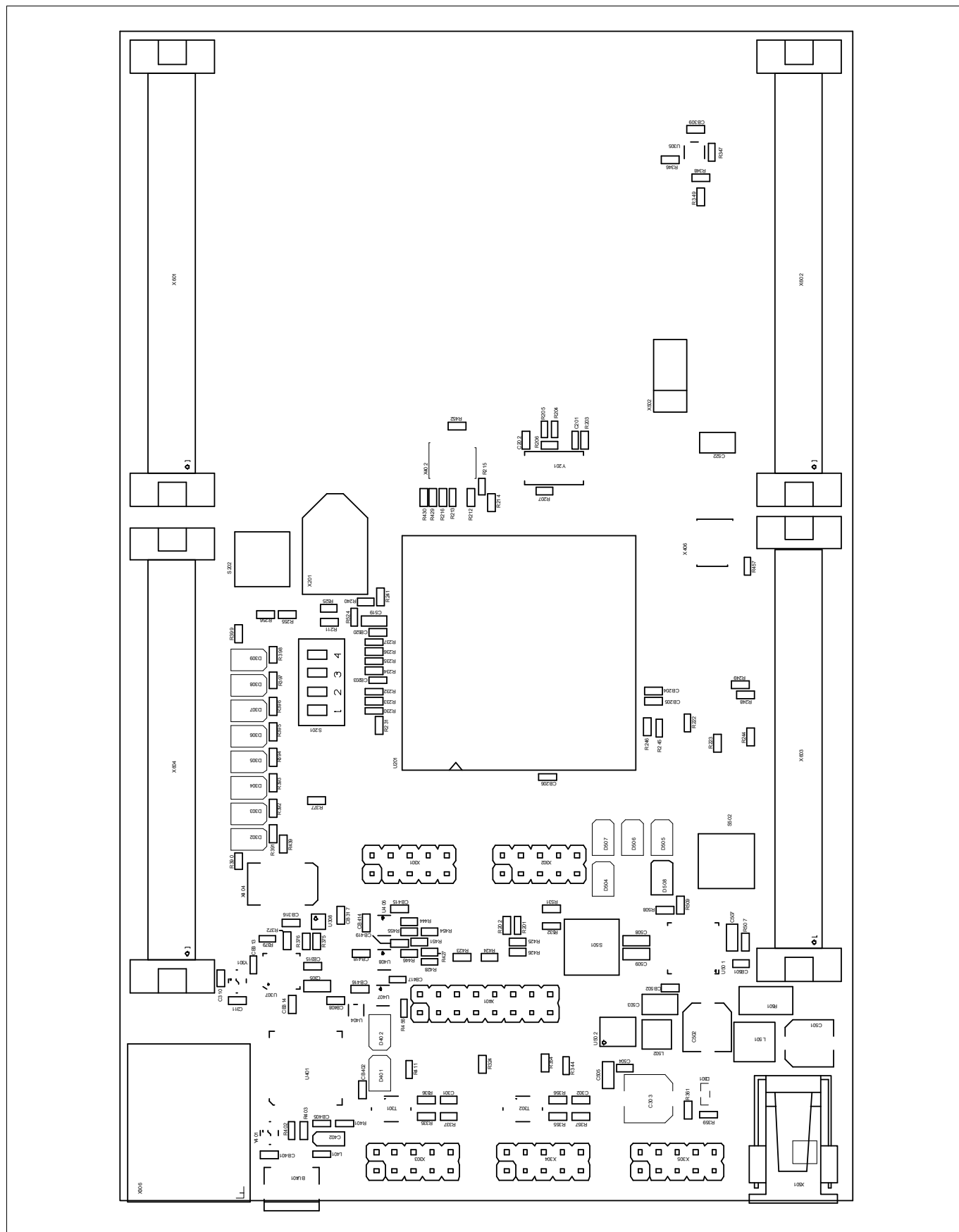

Figure 7-8 Component Plot Top Layer

Schematic and Layout

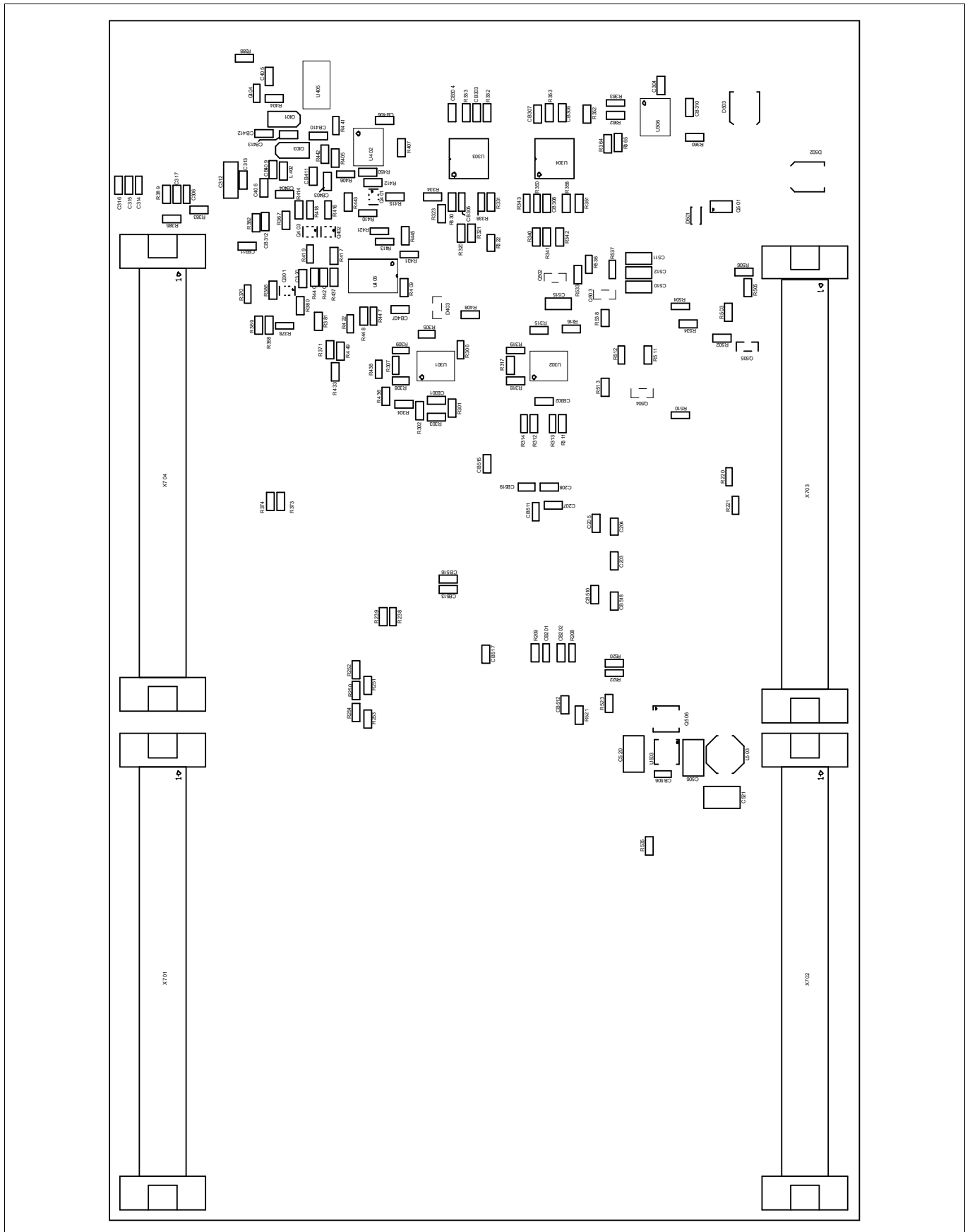

Figure 7-9 Component Plot Bottom Layer

7.4 Layout with Dimensioning

The following dimensions should be used for development of extension boards.

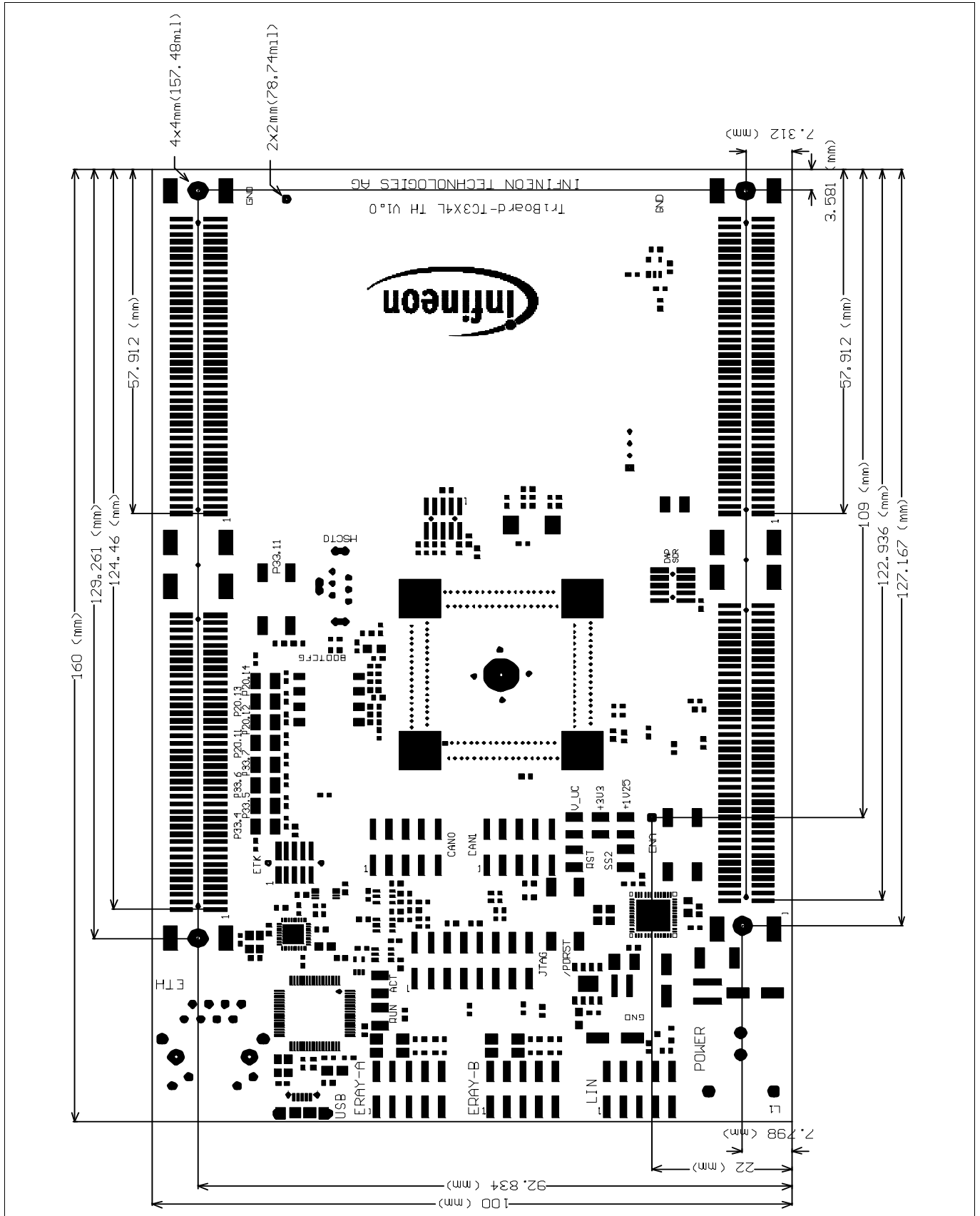

Figure 7-10 Dimensioning (mm)

Schematic and Layout

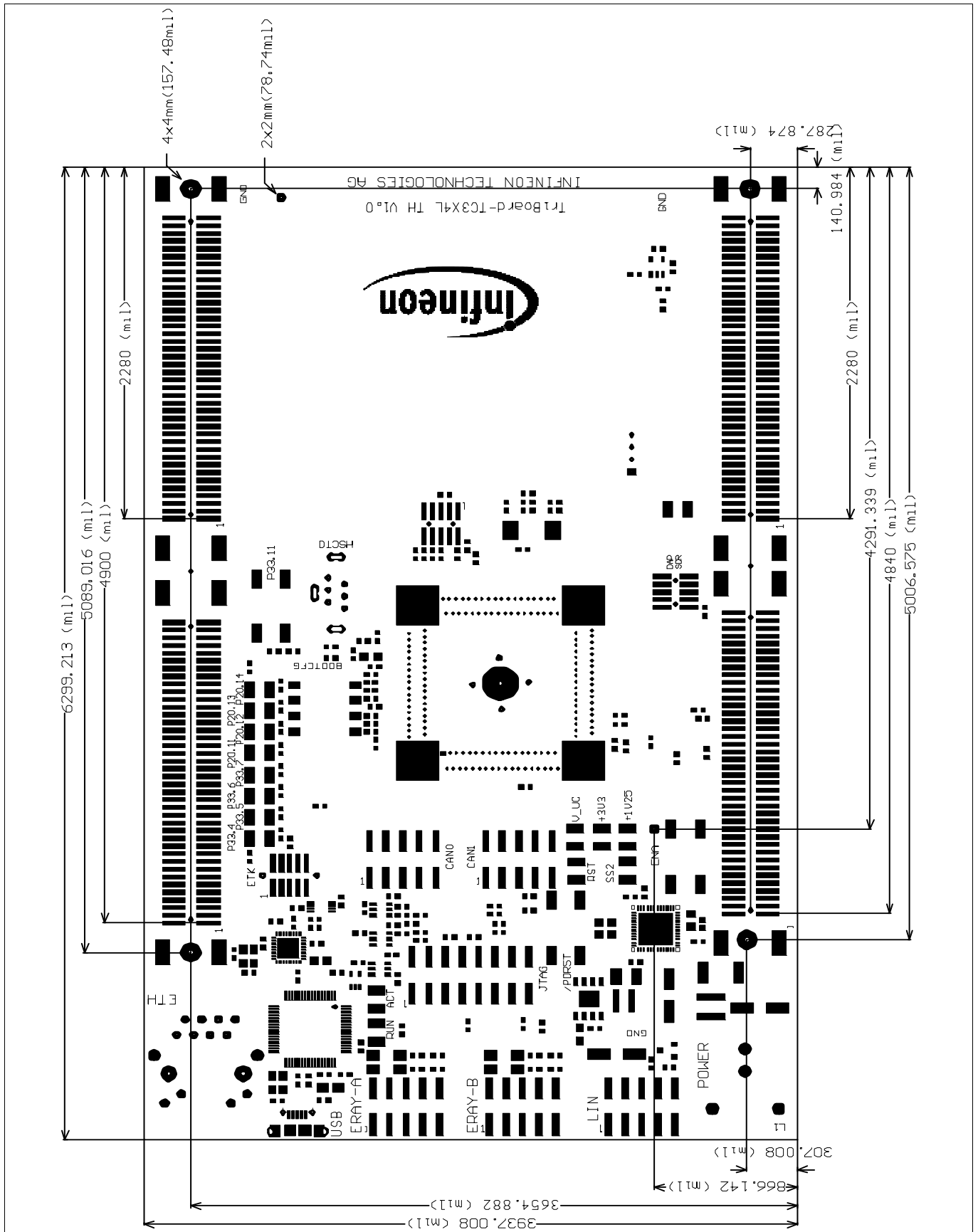

Figure 7-11 Dimensioning (mil)

The dimensioning is valid for all TriBoards.



Revision History

Page or Item	Subjects (major changes since previous revision)
V1.2, 2019-09	
Table 5-6	correct Short name and Description for SDO from TLF35584
chapter 3.10	add description for LIN master and slave changes
Revision History	add complete history of all previous versions
V1.1, 2019-06	
all	add TC364 in LQFP package as usable device and adapt description for this devices
chapter 3	add detailed description of usable devices/restricted devices
V1.0, 2017-11	
	First version

Trademarks of Infineon Technologies AG

μ HVIC™, μ IPM™, μ PFC™, AU-ConvertIR™, AURIX™, C166™, CanPAK™, CIPOS™, CIPURSE™, CoolDP™, CoolGaN™, COOLiR™, CoolMOS™, CoolSET™, CoolSiC™, DAVE™, DI-POL™, DirectFET™, DrBlade™, EasyPIM™, EconoBRIDGE™, EconoDUAL™, EconoPACK™, EconoPIM™, EiceDRIVER™, eupec™, FCOS™, GaNpowIR™, HEXFET™, HITFET™, HybridPACK™, iMOTION™, IRAM™, ISOFACE™, IsoPACK™, LEDriviR™, LITIX™, MIPAQ™, ModSTACK™, my-d™, NovalithIC™, OPTIGA™, OptiMOS™, ORIGA™, PowIRaudio™, PowIRstage™, PrimePACK™, PrimeSTACK™, PROFET™, PRO-SIL™, RASIC™, REAL3™, SmartLEWIS™, SOLID FLASH™, SPOC™, StrongIRFET™, SupIRBuck™, TEMPFET™, TRENCHSTOP™, TriCore™, UHVIC™, XHP™, XMC™.

Trademarks updated November 2015

Other Trademarks

All referenced product or service names and trademarks are the property of their respective owners.

Edition 2019-09

Published by

Infineon Technologies AG

81726 Munich, Germany

© 2019 Infineon Technologies AG.

All Rights Reserved.

Do you have a question about any aspect of this document?

Email: erratum@infineon.com

Document reference

Doc_Number

IMPORTANT NOTICE

The information given in this document shall in no event be regarded as a guarantee of conditions or characteristics ("Beschaffheitsgarantie").

With respect to any examples, hints or any typical values stated herein and/or any information regarding the application of the product, Infineon Technologies hereby disclaims any and all warranties and liabilities of any kind, including without limitation warranties of non-infringement of intellectual property rights of any third party.

In addition, any information given in this document is subject to customer's compliance with its obligations stated in this document and any applicable legal requirements, norms and standards concerning customer's products and any use of the product of Infineon Technologies in customer's applications.

The data contained in this document is exclusively intended for technically trained staff. It is the responsibility of customer's technical departments to evaluate the suitability of the product for the intended application and the completeness of the product information given in this document with respect to such application.

For further information on technology, delivery terms and conditions and prices, please contact the nearest Infineon Technologies Office (www.infineon.com).

WARNINGS

Due to technical requirements products may contain dangerous substances. For information on the types in question please contact your nearest Infineon Technologies office.

Except as otherwise explicitly approved by Infineon Technologies in a written document signed by authorized representatives of Infineon Technologies, Infineon Technologies' products may not be used in any applications where a failure of the product or any consequences of the use thereof can reasonably be expected to result in personal injury.