

Description: VII-H05VVF3G1,00-C13/3,0m, grey RAL 7032

Rating of cord set: 10A/250Vac

1. PLUG: Type VII

Molded plug according to : IEC60884, CEE (7) VII
Rated current and voltage : 16A, 250 V AC
Plugbase : thermoplastic Polyester(PBTP) GFR
Construction : double insulated
Pins : brass, nickel-plated, crimped
Pins outer diameter : 4,8 mm
Outer mold : PVC compound, hardness Shore A75-77
Approvals : VDE, ÖVE, CEPEC, KEMA, S-INTERTEK, D, N, FI, NF, IMQ, GOST

2. CORD: Type H05VVF3G1,00mm²

Flexible cord according to : ÖVE K41a;HD 21.5 S3:1994+A1:1999+A2:2001;
AS 3191, IEC 60227
Marked : *JF*<ÖVE><HAR>H05VVF3G1,0mm²*N1095*CE*CCC 60227
IEC 53(RVV) 300/500V 3X1,0*KTL SW01001-2001A
Number of cores : 3
Conductor construction : 31x0,20 mm O.D. 1,25mm
Conductor insulation : Extruded PVC O.D. 2,40mm
Jacket : Extruded PVC O.D. 6,80mm +/- 0,20mm
Temperature rating : -20°C up to +70°C
Resistance of conductors : max. 19,5 Ω/km
Dielectric strength : 2kVac, 1min.
Insulation resistance : >0,010MΩ/km
Color of conductors : yellow/green,brown,blue
Approvals : HARMONIZED, ÖVE, CCC, KTL

3. CONNECTOR: Type C13

Molded connector according to : EN/IEC60320/C13
Rated current and voltage : 10 A, 250 V AC
Construction : double insulation
Contacts of the connection : self-adjusting phosphor bronze CuSn6
Inner insulation : PPO GFR
Outer mold : PVC compound, hardness Shore A 75-77
Approvals : CE, ENEC

Environmental conformity

: EU-Directive 2002/96/EC (WEEE)
EU-Directive 2011/65/EU
EU-Directive 1907/2006 EG (REACH -compliant)

TESTING

Electrical testing : 100%
Visual inspection : 100%
High pot test wire to wire : 3kVac for 2 sec.
Continuity test : 25Aac to grounding / 20Aac to line and neutral
Polarity test : yes
Skin high pot test : 6kVac line to skin

Tolerances not indicated in the drawing: +/- 2 %
design subject to change without prior notice

DATE of ISSUE:	July, 2013		
REV: 1	1	ORIG:	mk

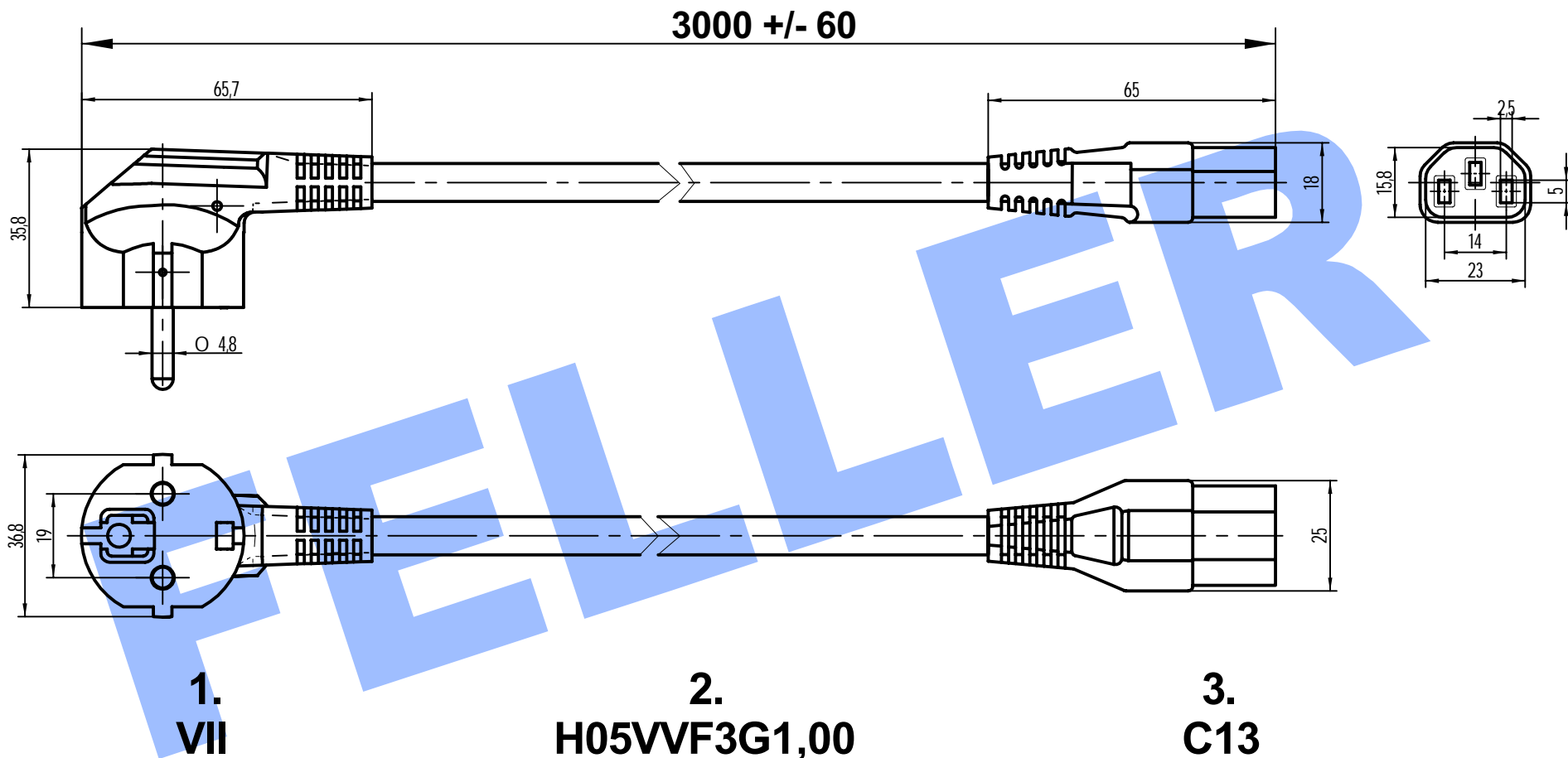

Fellertyp: VII-H05VVF3G1,00-C13/3,0m,greyscale RAL 7032

22.07.13

mk

All dimensions in mm

RoHS compliant

FELLER 

A-2525 Günselsdorf, Austria

Telefon 0043-2256-62325-0

Fax:0043-2256-62325-7

email: sales@feller-at.com

<http://www.feller-at.com>