

- 1
- 2
- 3
- 4
- 5
- 6
- 7
- 8
- 9
- 10
- 11
- 12
- 13
- 14
- 15
- 16
- 17
- 18

COVERING

Injected polyurethane, hardness 55 Shore D.

WHEEL CENTRE BODY

Polyamide based (PA) technopolymer.

ROLLING ACTION

Hub with pass-through hole.

FIXED PLATE BRACKET

Zinc-plated steel or AISI 304 stainless steel (SST version) sheet, the bracket is designed to withstand loads up to 3000N.

TURNING PLATE BRACKET

Zinc-plated steel or AISI 304 stainless steel (SST version) sheet, the bracket is designed to withstand loads up to 3000N.

The presence of a double ball race and direct contact between the plate and the ball race ring with built-in pin ensure excellent manoeuvrability. Does not require maintenance. It consists of (see Fig.1):

1. fitting plate: electrolytically zinc-plated steel or AISI 304 stainless steel sheet;
2. fork: electrolytically zinc-plated steel or AISI 304 stainless steel sheet;
3. ball race ring: electrolytically zinc-plated steel or AISI 304 stainless steel sheet;
4. central pin: incorporated in the plate, cold reflanged;
5. rotation system: dual grease-lubricated ball race;
6. dust seal: RAL 7015 dark grey technopolymer.

BRAKE

Total brake that locks the wheel and bracket rotation.

The optimised dimensions and the retractable pedal ensure minimal space occupied and maximum actuation ease. Hardened carbon steel or stainless steel (SST version) spring.

The trolley must be turned to use the device. The brake is simple and effective to use: it is actuated and released by a simple action from the top downward at the tip of two separate pedals, thus ensuring the utmost manoeuvring comfort.

STANDARD EXECUTIONS

- **PBL**: fixed plate bracket, without brake.
 - **SBL**: turning plate bracket, without brake.
 - **SBF**: turning plate bracket, with brake.
 - **FBL**: turning plate bracket and centre pass-through hole, without brake.
 - **FBF**: turning plate bracket and centre pass-through hole, with brake.
- Index for bracket material:
- **N**: zinc-plated steel plate bracket.
 - **N-SST**: AISI 304 stainless steel bracket.

APPLICATIONS

Excellent rolling resistance and elasticity features, good wear and tearing resistance.

For further information see wheel technical data sheet RE.FF (see page 1665).

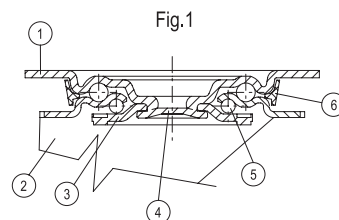

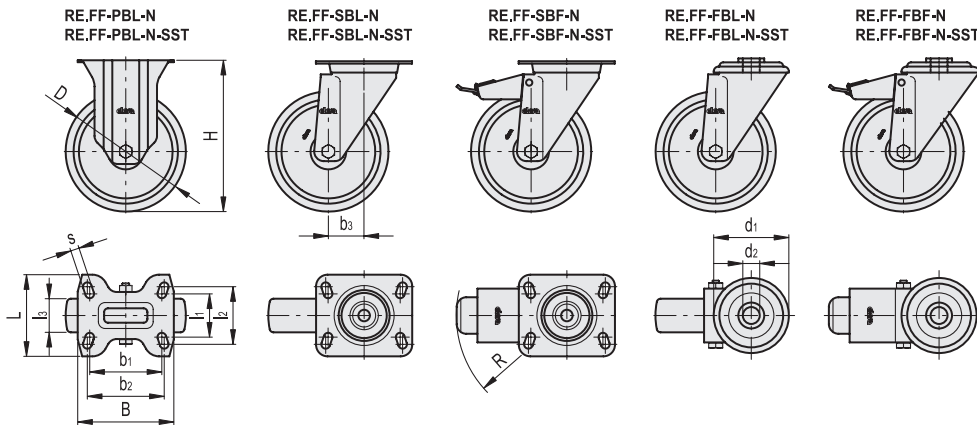

RE.FF-N

Code	Description	D	d1	d2	l1	l2	l3	H	B	L	s	b1	b2	b3	R	Rolling resistance# [N]	Dynamic carrying capacity# [N]	⚖
451151	RE.FF-080-PBL-N	80	-	-	45	60	30	107	100	85	9	75	80	-	-	1200	1200	380
451156	RE.FF-100-PBL-N	100	-	-	45	60	30	128	100	85	9	75	80	-	-	1700	1700	430
451161	RE.FF-125-PBL-N	125	-	-	45	60	35	156	100	85	9	75	80	-	-	2300	2200	660
451166	RE.FF-150-PBL-N	150	-	-	73	85	45	194	140	114	11	105	105	-	-	2800	3000	1460
451051	RE.FF-080-SBL-N	80	-	-	45	60	30	107	100	85	9	75	80	39	-	1200	1200	620
451056	RE.FF-100-SBL-N	100	-	-	45	60	30	128	100	85	9	75	80	35	-	1700	1700	740
451061	RE.FF-125-SBL-N	125	-	-	45	60	35	156	100	85	9	75	80	37	-	2300	2200	910
451066	RE.FF-150-SBL-N	150	-	-	73	87	45	194	140	110	11	105	105	56	-	2800	3000	1830
451101	RE.FF-080-SBF-N	80	-	-	45	60	30	107	100	85	9	75	80	39	120	1200	1200	810
451106	RE.FF-100-SBF-N	100	-	-	45	60	30	128	100	85	9	75	80	35	120	1700	1700	890
451111	RE.FF-125-SBF-N	125	-	-	45	60	35	156	100	85	9	75	80	37	120	2300	2200	1050
451116	RE.FF-150-SBF-N	150	-	-	73	87	45	194	140	110	11	105	105	56	156	2800	3000	2110
451171	RE.FF-80-FBL-N	80	73	12	-	-	30	107	-	-	-	-	-	39	-	1200	1200	550
451173	RE.FF-100-FBL-N	100	73	12	-	-	30	128	-	-	-	-	-	35	-	1700	1700	670
451176	RE.FF-125-FBL-N	125	73	12	-	-	35	156	-	-	-	-	-	37	-	2300	2200	850
451179	RE.FF-150-FBL-N	150	102	20	-	-	45	188	-	-	-	-	-	56	-	2800	3000	1690
451181	RE.FF-80-FBF-N	80	73	12	-	-	30	107	-	-	-	-	-	39	120	1200	1200	730
451183	RE.FF-100-FBF-N	100	73	12	-	-	30	128	-	-	-	-	-	35	120	1700	1700	880
451186	RE.FF-125-FBF-N	125	73	12	-	-	35	156	-	-	-	-	-	37	120	2300	2200	1000
451189	RE.FF-150-FBF-N	150	102	20	-	-	45	188	-	-	-	-	-	56	156	2800	3000	1980

RE.FF-SST-N



Code	Description	D	d1	d2	l1	l2	l3	H	B	L	s	b1	b2	b3	R	Rolling resistance# [N]	Dynamic carrying capacity# [N]	⚖
451301	RE.FF-080-PBL-SST-N	80	-	-	45	60	30	107	100	85	9	75	80	-	-	1200	1200	350
451306	RE.FF-100-PBL-SST-N	100	-	-	45	60	30	128	100	85	9	75	80	-	-	1700	1700	400
451311	RE.FF-125-PBL-SST-N	125	-	-	45	60	35	156	100	85	9	75	80	-	-	2300	2200	640
451201	RE.FF-080-SBL-SST-N	80	-	-	45	60	30	107	100	85	9	75	80	39	-	1200	1200	610
451206	RE.FF-100-SBL-SST-N	100	-	-	45	60	30	128	100	85	9	75	80	35	-	1700	1700	650
451211	RE.FF-125-SBL-SST-N	125	-	-	45	60	35	156	100	85	9	75	80	37	-	2300	2200	810
451251	RE.FF-080-SBF-SST-N	80	-	-	45	60	30	107	100	85	9	75	80	39	120	1200	1200	780
451256	RE.FF-100-SBF-SST-N	100	-	-	45	60	30	128	100	85	9	75	80	35	120	1700	1700	830
451261	RE.FF-125-SBF-SST-N	125	-	-	45	60	35	156	100	85	9	75	80	37	120	2300	2200	950
451351	RE.FF-080-FBL-SST-N	80	73	12	-	-	30	107	-	-	-	-	-	39	-	1200	1200	550
451353	RE.FF-100-FBL-SST-N	100	73	12	-	-	30	128	-	-	-	-	-	35	-	1700	1700	670
451356	RE.FF-125-FBL-SST-N	125	73	12	-	-	35	156	-	-	-	-	-	37	-	2300	2200	850
451361	RE.FF-080-FBF-SST-N	80	73	12	-	-	30	107	-	-	-	-	-	39	120	1200	1200	550
451363	RE.FF-100-FBF-SST-N	100	73	12	-	-	30	128	-	-	-	-	-	35	120	1700	1700	670
451366	RE.FF-125-FBF-SST-N	125	73	12	-	-	35	156	-	-	-	-	-	37	120	2300	2200	860

For rolling resistance and dynamic carrying capacity see Technical data (on page 1704).

