

5

4

3

2

1

## 受控 CONTROLLED DOCUMENT

编号 P/N	25-7660-CUST	版本 Rev	01	日期 Rel'd Date	SEP 14,09
-----------	--------------	-----------	----	------------------	-----------

Description: F-61 AD Chassis MT. Female

Part No: 25-7660

Application: Chassis Mount

Crimp Tool: N/A

Impedance: 75 Ohms

Frequency Range: 0-750 MHz

Material: Body Brass Nickel plated

Contact Beryllium Tin plated

Insulator PE

Washer Brass Nickel plated

Nut Steel Nickel plated

RoHS Compliance: Yes

Technical Detail: Refer to Emerson Document P/N 25-0000



DRAWING NO.

25-7660-CUST

## REVISIONS

01	OFFICIAL RELEASE				2009.09.06
	08-18-09	Y	U	U	TH

D

D

C

C

B

B

A

A

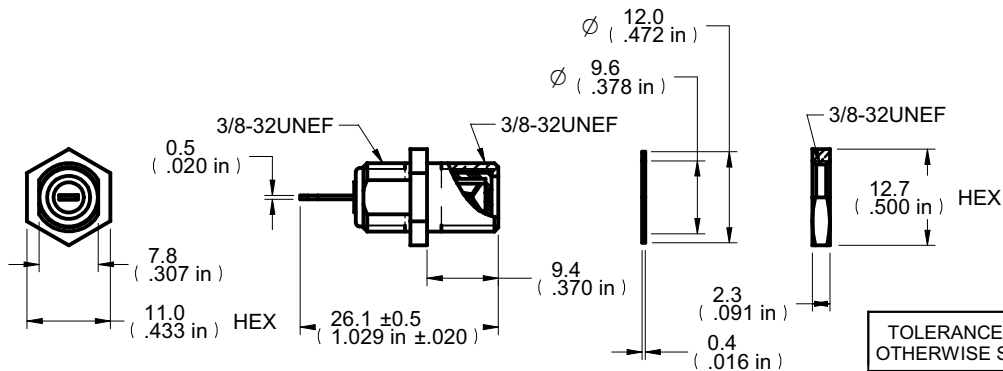
**DIM OUTLINE**

CUSTOMER COPY

TOLERANCE UNLESS OTHERWISE SPECIFIED		DRAWN BY	DATE
DECIMALS	mm	BETTY.YU	08-18-09
X	± 0.5	CHECKED BY	DATE
X.X	± 0.3	BETTY.YU	08-18-09
X.XX	± 0.1	APPROVED BY	DATE
ANGLES	± 0.5°	THOMAS	08-18-09
	U/M	mm	⊕

TITLE  
F-61 AD CHASSIS MT. FEMALE

SHEET	DRAWING NO.	SIZE
1 OF 1	25-7660-CUST	A

THIS DRAWING WAS PRODUCED BY COMPUTER,  
DO NOT SCALE DRAWING OR UPDATE MANUALLY.

5

4

3

2

1