

E30468

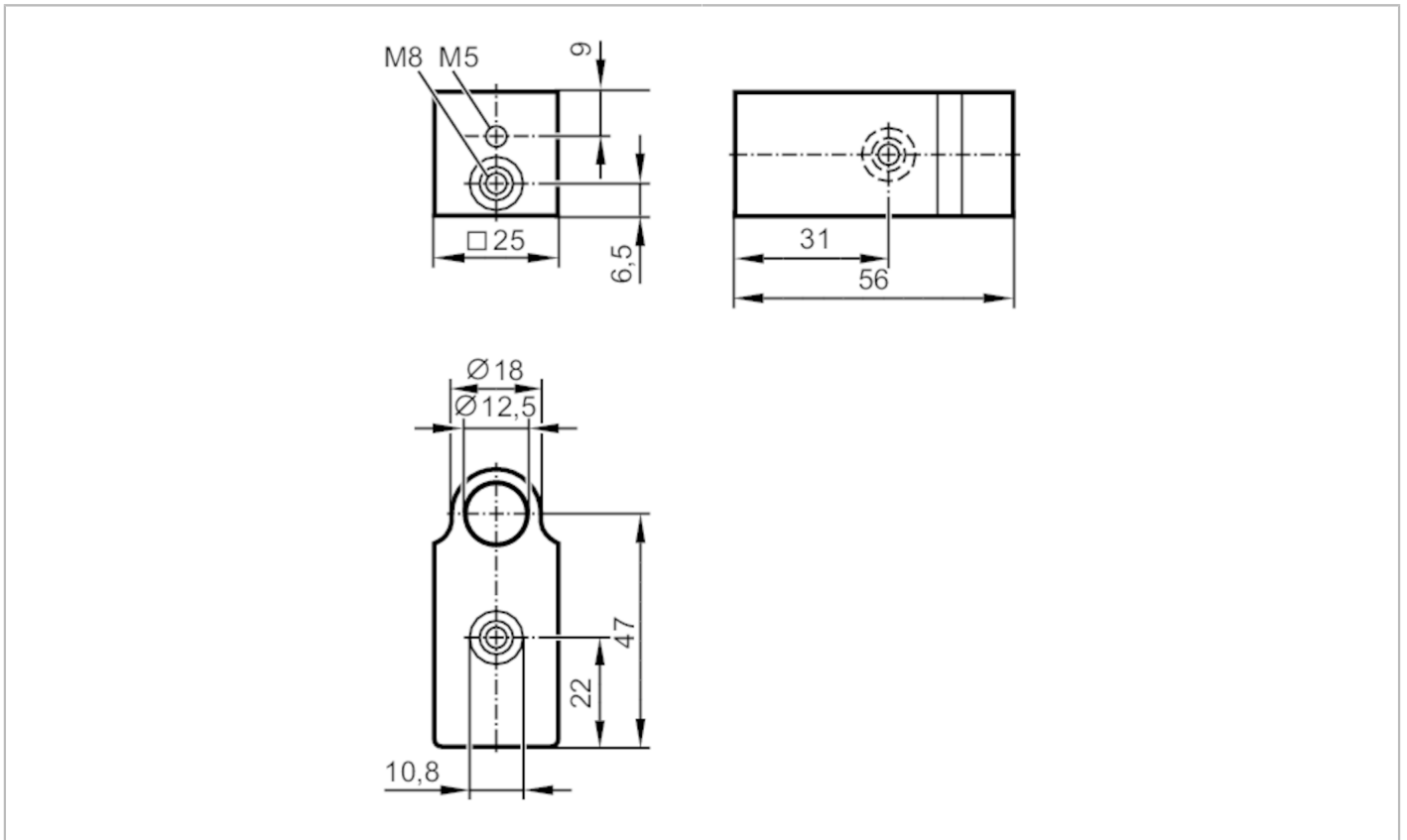

Mounting adapter

ADAPT M10/M12 FOR VIBRATION SENSORS



Application	
Application	Accessories for vibration monitoring systems - Mounting adapters
Installation	Ø 10 / Ø 12 mm
Mechanical data	
Weight [g]	72
Materials	aluminium uncoloured anodised
Sensor connection	M5 x 0,8 / M8 x 1,25 internal thread
Remarks	
Pack quantity	1 pcs.