



Part no.: 50136770
DTKS 30x50
Reflector



Figure can vary

Contents

- Technical data
- Dimensioned drawings
- Diagrams

Part no.: 50136770 – DTKS 30x50 – Reflector

Technical data

Basic data	
Suitable for	PRK5.R3
Optical data	
Operating range	0.1 ... 0.3 m
Mechanical data	
Design	Rectangular
Mounting dimension, width	34 mm
Reflection surface width	25.9 mm
Mounting dimension, height	75 mm
Reflection surface height	42.5 mm
Mounting dimension, thickness	7 mm
Direction independent	No
Triple reflector size	2.3 mm
Reflector material	Plastic
Material of base material	Plastic
Chemical designation, reflector material	PMMA
Structure, active surface	Triple
Net weight	13.5 g
Type of fastening	Adhesive Through-hole mounting
Type of reflector	Reflector
Environmental data	
Ambient temperature, operation	-40 ... 70 °C
Certifications	
Degree of protection	IP 67
Classification	
Customs tariff number	90029000
eCl@ss 8.0	27279203
eCl@ss 9.0	27273601
ETIM 5.0	EC002467
ETIM 6.0	EC002467

Dimensioned drawings

All dimensions in millimeters

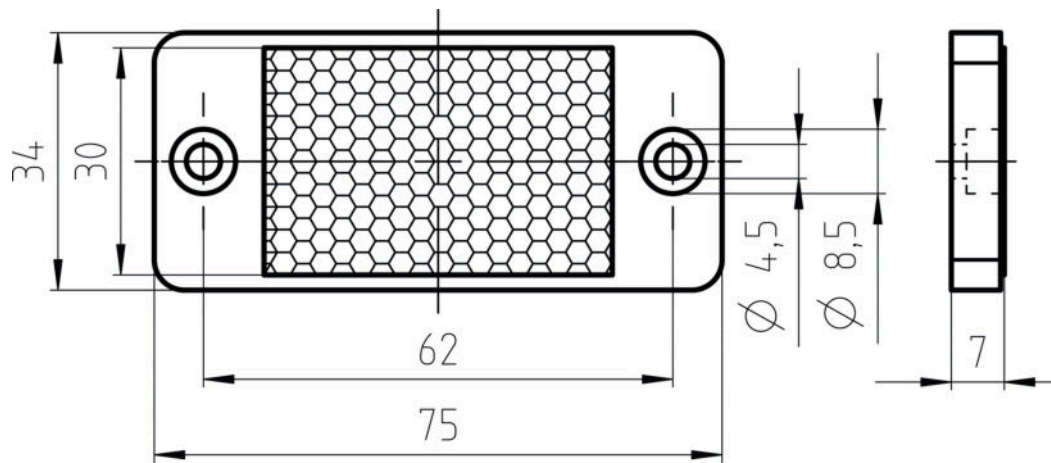

Diagrams

Mounting instruction

