

5550 3537	DATENBLATT	
Gültig ab: 10.07.2018	SILVYN® HIPROJACKET AMG PG	

SILVYN® HIPROJACKET AMG PG ist eine PG Verschraubung aus vernickeltem Messing. Die Verschraubung ist passend für SILVYN® HIPROJACKET und kann in der Stahlverarbeitende Industrie, Ofenbau, Kunststoffindustrie, Maschinenbau und bei extremer Hitze eingesetzt werden.



Material:

Grundkörper	Messing, vernickelt
Einschraubhülse	Messing, vernickelt
Mutter	Messing, vernickelt
Klemmring	Messing, vernickelt
Tülle	Polyamid 6
O-Ring	NBR

Technische Merkmale:

Anschlussgewinde	PG 9 bis PG 48 nach DIN 40430
Nennweite	NW 5/16“ bis NW 2“
Schutzart	IP67 nach EN 60529
Temperaturbereich	Abhängig von dem verwendeten Schutzschlauch -45°C bis +105°C Ohne die Kunststoffkomponenten kann ein höherer Temperaturbereich erzielt werden



Zulassungen:

Referenz Normen:

IEC 61386-1

Passende Schläuche:

SILVYN® HIPROJACKET

Passendes Zubehör:

SILVYN® HIPROSILTAPE

Weitere Angaben entnehmen Sie bitte unserem aktuellen Katalog.
Bei Beständigkeitsfragen über aggressive Medien oder bestimmte Öle kann unser Labor Sie gerne beraten.

Ersteller: MAAU1/PDP Freigegeben: DAMU1/PDP	Dokument: DB55503537DE Version: 01	Seite 1 von 3
--	---------------------------------------	---------------

Technische Zeichnung:

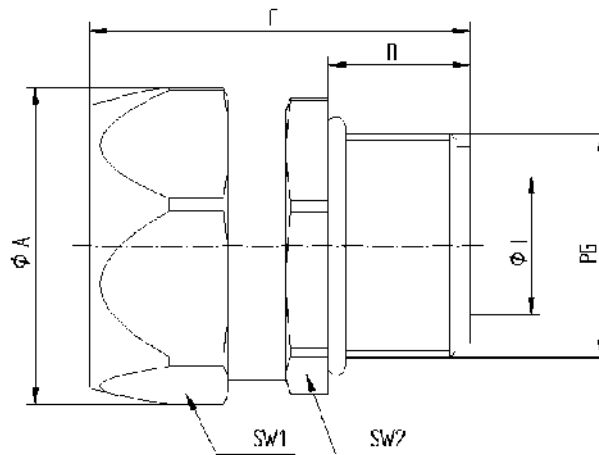
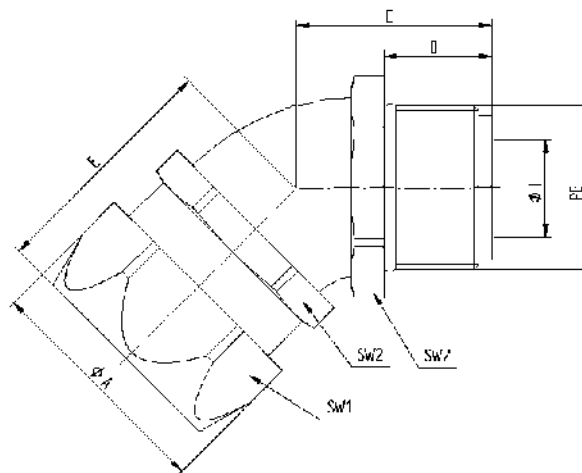
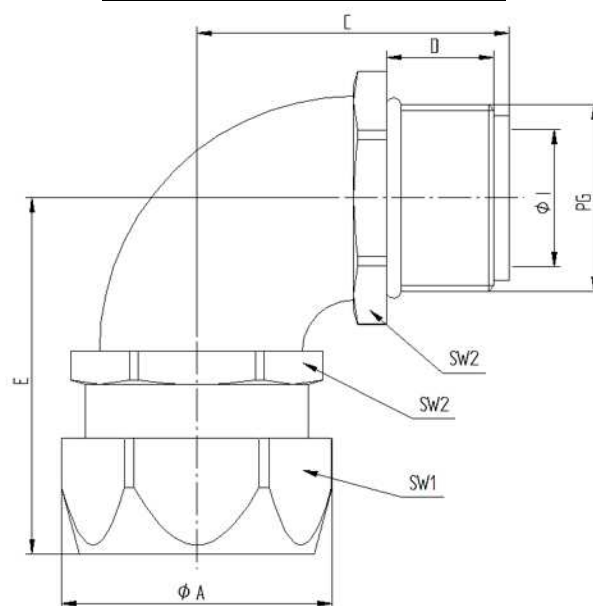
SILVYN HIPOJACKET AMG PG**SILVYN HIPOJACKET AMG 45° PG****SILVYN HIPOJACKET AMG 90° PG**

5550 3537	DATENBLATT	
Gültig ab: 10.07.2018	SILVYN® HIPROJACKET AMG PG	

Maßtabelle:

Artikel Nr.	Nennweite NW	Gewinde PG	Gewinde Länge mm D	Länge mm		Durchmesser mm		Schlüsselweite		Gewicht Kg/100
				C	E	Ø I	Ø A	SW 1	SW 2	
SILVYN® HIPROJACKET AMG PG										
5550 3537	5/16"	PG 9	12,0	35,0	-	8,3	29,0	26	24	4,8
5550 3538	5/16"	PG 11	12,0	35,0	-	8,3	29,0	26	24	5,6
5550 3539	3/8"	PG 13,5	12,0	35,0	-	10,2	29,0	26	24	5,6
5550 3540	1/2"	PG 16	13,0	37,0	-	13,9	32,7	29	27	6,3
5550 3541	3/4"	PG 21	15,0	40,0	-	18,5	38,7	35	33	8,4
5550 3542	1"	PG 29	15,0	46,0	-	23,8	50,0	45	43	25,0
5550 3543	1 1/4"	PG 36	16,0	52,0	-	31,8	60,0	54	52	34,6
5550 3544	1 1/2"	PG 42	18,0	56,0	-	36,8	69,2	63	60	47,2
5550 3499	2"	PG 48	20,0	66,0	-	47,8	85,0	77	74	72,0
SILVYN® HIPROJACKET AMG 45° PG										
5550 3500	5/16"	PG 11	12,0	23,0	33,0	8,3	29,0	26	22	8,1
5550 3501	3/8"	PG 13,5	12,0	23,0	33,0	10,2	29,0	26	22	8,1
5550 3502	1/2"	PG 16	13,0	25,0	33,0	13,9	32,7	29	27	11,6
5550 3503	3/4"	PG 21	15,0	30,0	36,0	18,5	38,7	35	33	15,3
5550 3504	1"	PG 29	15,0	34,0	46,0	23,8	50,0	45	42	31,5
5550 3505	1 1/4"	PG 36	16,0	39,0	54,0	31,8	60,0	54	51	53,2
5550 3506	1 1/2"	PG 42	18,0	45,0	59,0	36,8	69,2	63	60	78,5
5550 3507	2"	PG 48	20,0	53,0	71,0	47,8	85,0	77	74	132,0
SILVYN® HIPROJACKET AMG 90° PG										
5550 3508	5/16"	PG 11	12,0	32,0	42,0	8,3	29,0	26	22	8,9
5550 3509	3/8"	PG 13,5	12,0	32,0	42,0	10,2	29,0	26	22	8,9
5550 3510	1/2"	PG 16	13,0	36,0	43,0	13,9	32,7	29	27	15,3
5550 3511	3/4"	PG 21	15,0	43,0	48,0	18,5	38,7	35	33	21,6
5550 3512	1"	PG 29	15,0	48,0	59,0	23,8	50,0	45	42	35,3
5550 3513	1 1/4"	PG 36	16,0	57,0	68,0	31,8	60,0	54	51	62,5
5550 3514	1 1/2"	PG 42	18,0	63,0	78,0	36,8	69,2	63	60	88,1
5550 3515	2"	PG 48	20,0	74,0	96,0	47,8	85,0	77	74	141,9

Ersteller: MAAU1/PDP Freigegeben: DAMU1/PDP	Dokument: DB55503537DE Version: 01	Seite 3 von 3
--	---------------------------------------	---------------