

Toothed belt axes EGC-TB-KF, with recirculating ball bearing guide

FESTO



Festo core product range
Covers 80% of your automation tasks

Worldwide:

Always in stock

Superb:

Festo quality at an attractive price

Easy:

Simplified procurement and warehousing

★ Generally ready for dispatch from the factory within 24 hours

In stock at 13 Service Centres worldwide

More than 2200 products

★ Generally ready for dispatch from the factory within 5 days

Assembled for you at 4 Service Centres worldwide

Up to 6×10^{12} variants per product series

Just look
for the
star!

Selection aid

Overview of toothed belt and spindle axes

Toothed belt axes

- Speeds of up to 10 m/s
- Acceleration of up to 50 m/s²
- Repetition accuracy of up to ±0.08 mm
- Strokes of up to 8500 mm (longer strokes on request)
- Flexible motor mounting

Spindle axes

- Velocities of up to 2 m/s
- Acceleration of up to 20 m/s²
- Repetition accuracy of up to ±0.003 mm
- Strokes of up to 3000 mm

Coordinate system

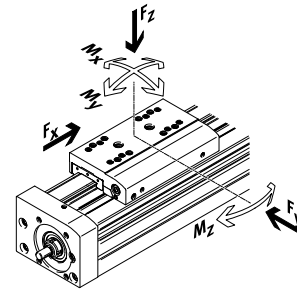

Toothed belt axes

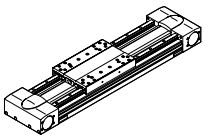
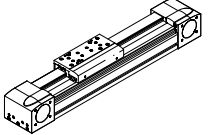
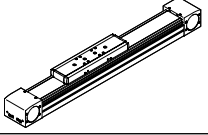
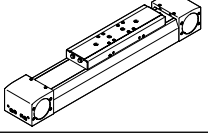
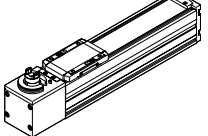
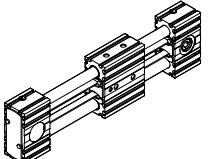
Type	F_x [N]	v [m/s]	M_x [Nm]	M_y [Nm]	M_z [Nm]	Characteristics
Heavy-duty recirculating ball bearing guide						
EGC-HD-TB						
	450 1000 1800	3 5 5	140 300 900	275 500 1450	275 500 1450	<ul style="list-style-type: none"> • Flat drive unit with rigid, closed profile • Precision DUO guide rail with high load capacity • Ideal as a base axis for linear gantries and cantilever axes
Recirculating ball bearing guide						
EGC-TB-KF						
	50 100 350 800 2500	3 5 5 5 5	3.5 16 36 144 529	10 132 228 680 1820	10 132 228 680 1820	<ul style="list-style-type: none"> • Rigid, closed profile • Precision guide rail with high load capacity • Small drive pinions reduce required driving torque • Space-saving position sensing
ELGA-TB-KF						
	350 800 1300 2000	5 5 5 5	16 36 104 167	132 228 680 1150	132 228 680 1150	<ul style="list-style-type: none"> • Internal guide and toothed belt • Precision guide rail with high load capacity • Guide and toothed belt protected by cover strip • High feed forces
ELGA-TB-KF-F1						
	260 600 1000	5 5 5	16 36 104	132 228 680	132 228 680	<ul style="list-style-type: none"> • Suitable for use in the food zone • "Clean look": smooth, easy-to-clean surfaces • Internal guide and toothed belt • Precision guide rail with high load capacity • Guide and toothed belt protected by cover strip
ELGC-TB-KF						
	75 120 250	1.2 1.5 1.5	5.5 29.1 59.8	4.7 31.8 56.2	4.7 31.8 56.2	<ul style="list-style-type: none"> • Internal guide and toothed belt • Precision guide rail with high load capacity • Guide and toothed belt protected by cover strip
ELGR-TB						
	50 100 350	3 3 3	2.5 5 15	20 40 124	20 40 124	<ul style="list-style-type: none"> • Cost-optimised rod guide • Ready-to-install unit • Linear bushings with high load capacity for dynamic operation

Selection aid

Overview of toothed belt and spindle axes

Toothed belt axes

- Speeds of up to 10 m/s
- Acceleration of up to 50 m/s²
- Repetition accuracy of up to ±0.08 mm
- Strokes of up to 8500 mm (longer strokes on request)
- Flexible motor mounting

Spindle axes

- Velocities of up to 2 m/s
- Acceleration of up to 20 m/s²
- Repetition accuracy of up to ±0.003 mm
- Strokes of up to 3000 mm

Coordinate system

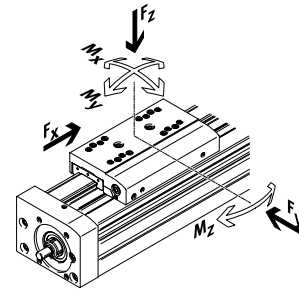

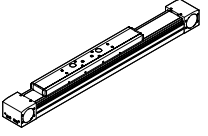
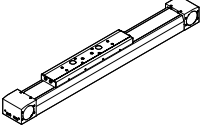
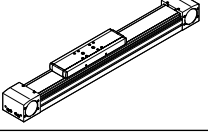
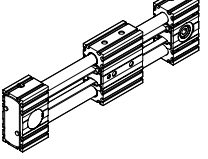
Toothed belt axes						
Type	F_x [N]	v [m/s]	M_x [Nm]	M_y [Nm]	M_z [Nm]	Characteristics
Roller bearing guide						
ELGA-TB-RF						
	350	10	11	40	40	<ul style="list-style-type: none"> • Heavy-duty roller bearing guide • Guide and toothed belt protected by cover strip • Speeds of up to 10 m/s • Lower weight than axes with guide rails
	800	10	30	180	180	
	1300	10	100	640	640	
ELGA-TB-RF-F1						
	260	10	8.8	32	32	<ul style="list-style-type: none"> • Suitable for use in the food zone • "Clean look": smooth, easy-to-clean surfaces • Heavy-duty roller bearing guide • Guide and toothed belt protected by cover strip • Lower weight than axes with guide rails
	600	10	24	144	144	
	1000	10	80	512	512	
Plain-bearing guide						
ELGA-TB-G						
	350	5	5	30	10	<ul style="list-style-type: none"> • Guide and toothed belt protected by cover strip • For simple handling tasks • As a drive component for external guides • Insensitive to harsh ambient conditions
	800	5	10	60	20	
	1300	5	120	120	40	
ELGR-TB-GF						
	50	1	1	10	10	<ul style="list-style-type: none"> • Cost-optimised rod guide • Ready-to-install unit • Heavy-duty plain bearings for use in harsh environmental conditions
	100	1	2.5	20	20	
	350	1	1	40	40	

Selection aid

Overview of toothed belt and spindle axes

Toothed belt axes

- Speeds of up to 10 m/s
- Acceleration of up to 50 m/s²
- Repetition accuracy of up to ±0.08 mm
- Strokes of up to 8500 mm (longer strokes on request)
- Flexible motor mounting

Spindle axes

- Velocities of up to 2 m/s
- Acceleration of up to 20 m/s²
- Repetition accuracy of up to ±0.003 mm
- Strokes of up to 3000 mm

Coordinate system

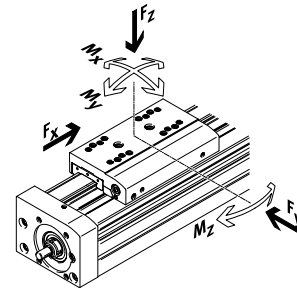

Spindle axes

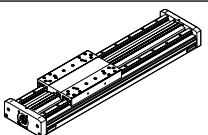
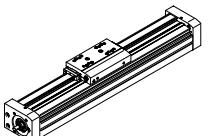
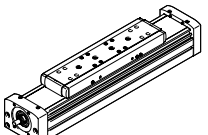
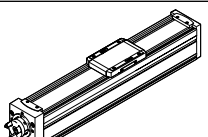
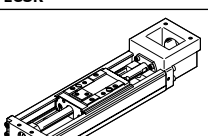
Type	F_x [N]	v [m/s]	M_x [Nm]	M_y [Nm]	M_z [Nm]	Characteristics
Heavy-duty recirculating ball bearing guide						
EGC-HD-BS						
	400 650 1500	0.5 1.0 1.5	140 300 900	275 500 1450	275 500 1450	<ul style="list-style-type: none"> • Flat drive unit with rigid, closed profile • Precision DUO guide rail with high load capacity • Ideal as a base axis for linear gantries and cantilever axes
Recirculating ball bearing guide						
EGC-BS-KF						
	400 650 1500 3000	0.5 1.0 1.5 2.0	16 36 144 529	132 228 680 1820	132 228 680 1820	<ul style="list-style-type: none"> • Rigid, closed profile • Precision guide rail with high load capacity • For the highest requirements in terms of feed force and accuracy • Space-saving position sensing
ELGA-BS-KF						
	650 1600 3400 6400	0.5 1.0 1.5 2.0	16 36 104 167	132 228 680 1150	132 228 680 1150	<ul style="list-style-type: none"> • Internal guide and ball screw drive • Precision guide rail with high load capacity • For the highest requirements in terms of feed force and accuracy • Guide and ball screw drive protected by cover strip • Space-saving position sensing
ELGC-BS-KF						
	40 100 200 350	0.6 0.6 0.8 1.0	1.3 5.5 29.1 59.8	1.1 4.7 31.8 56.2	1.1 4.7 31.8 56.2	<ul style="list-style-type: none"> • Internal guide and ball screw drive • Guide and ball screw drive protected by cover strip • Space-saving position sensing
EGSK						
	57 133 184 239 392	0.33 1.10 0.83 1.10 1.48	13 28.7 60 79.5 231	3.7 9.2 20.4 26 77.3	3.7 9.2 20.4 26 77.3	<ul style="list-style-type: none"> • Spindle axes with maximum precision, compactness and rigidity • Recirculating ball bearing guide and ball screw drive without caged ball bearings • Standard designs in stock

Key features

At a glance

- Generously sized profiles with an optimised cross section afford maximum rigidity and load capacity
- Velocity, acceleration and torque resistance set a new standard
- Numerous sizes and variants such as protected guides open up a broad range of applications
- Due to the EGC's high performance it is often possible to use a smaller size
- Space-saving position sensing possible via proximity switch in the profile slot
- Toothed belt material can be selected from:
 - Chloroprene rubber for long service life
 - Coated PU with steel reinforcements for long service life and resilience to certain cooling lubricants
- Wide range of options for mounting on drives
- Comprehensive range of mounting accessories for multi-axis combinations
- EX3: for use in potentially explosive areas

Flexible motor mounting

The motor position can be freely selected on 4 sides and can be changed at any time.



Comprehensive range for the most varied load conditions

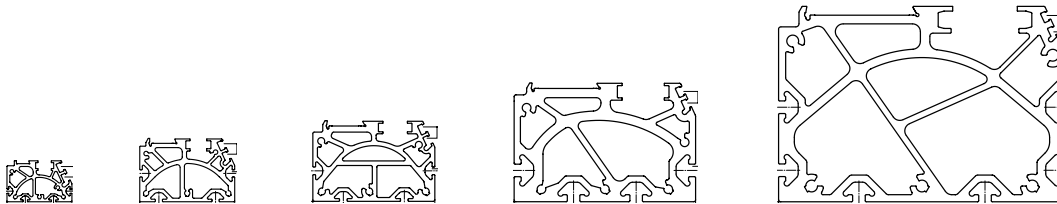

Characteristic values of the axes

The specifications shown in the table are maximum values.

The precise values for each of the variants can be found in the relevant data sheet in the catalogue.

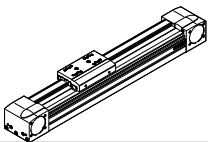
Version	Size	Working stroke [mm]	Velocity [m/s]	Repetition accuracy [mm]	Feed force [N]	Guide characteristics				
						Forces and torques				
						Fy [N]	Fz [N]	Mx [Nm]	My [Nm]	Mz [Nm]
Recirculating ball bearing guide										
	50	50 ... 1900	3	±0.08	50	650	650	3.5	10	10
	70	50 ... 5000	5	±0.08	100	1850	1850	16	132	132
	80	50 ... 8500	5	±0.08	350	3050	3050	36	228	228
	120	50 ... 8500	5	±0.08	800	6890	6890	144	680	680
	185	50 ... 8500	5	±0.1	2500	15200	15200	529	1820	1820

 **Note**
Engineering software
PositioningDrives
www.festo.com

Characteristics

Slide variants

Standard slide



Extended slide



Additional slide



Guide options

Protected version

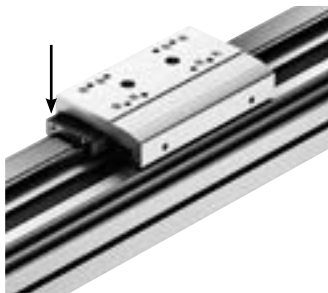

- The protected guide cleans the guide rail and protects the recirculating ball bearing guide with the aid of an additional wiper seal

With central lubrication

→ Page 23

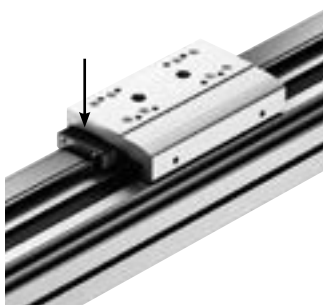

- The lubrication adapter enables the guide to be permanently lubricated using semi or fully automatic relubrication devices
- The adapters are suitable for oils and greases
- Both lubrication adapters must be connected

Displacement encoder

→ Page 14



- The position of the slide can be sensed directly when using the incremental displacement encoder. This means that all elasticities of the drive train can be detected and can be corrected by the motor controller.

Clamping unit

→ Page 15

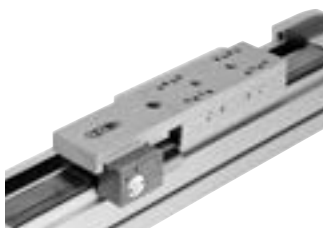

- 1- or 2-channel design, for holding loads
- Reliable holding is guaranteed since the forces act directly on the slide
- A limited number of emergency braking operations are permissible with the sizes 120 and 185

Characteristics

Complete system comprising toothed belt axis, motor, motor controller and motor mounting kit

Toothed belt axis with recirculating ball bearing guide



Motor

→ Page 46

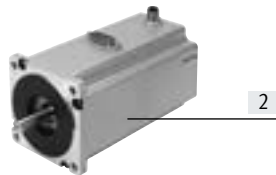
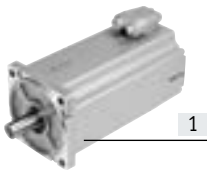

- [1] Servo motor EMME-AS, EMMS-AS
- [2] Stepper motor EMMS-ST



Note

For the toothed belt axis EGC and the motors, there are specially adapted complete solutions.

Motor controller

Data sheets → Internet: motor controller

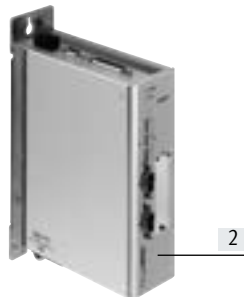

- [1] Servo motor controller CMMP-AS
- [2] Stepper motor controller CMMS-ST

Motor mounting kit

→ Page 46

Axial kit



Kit comprising:

- Motor flange
- Coupling housing
- Coupling
- Screws

Peripherals overview

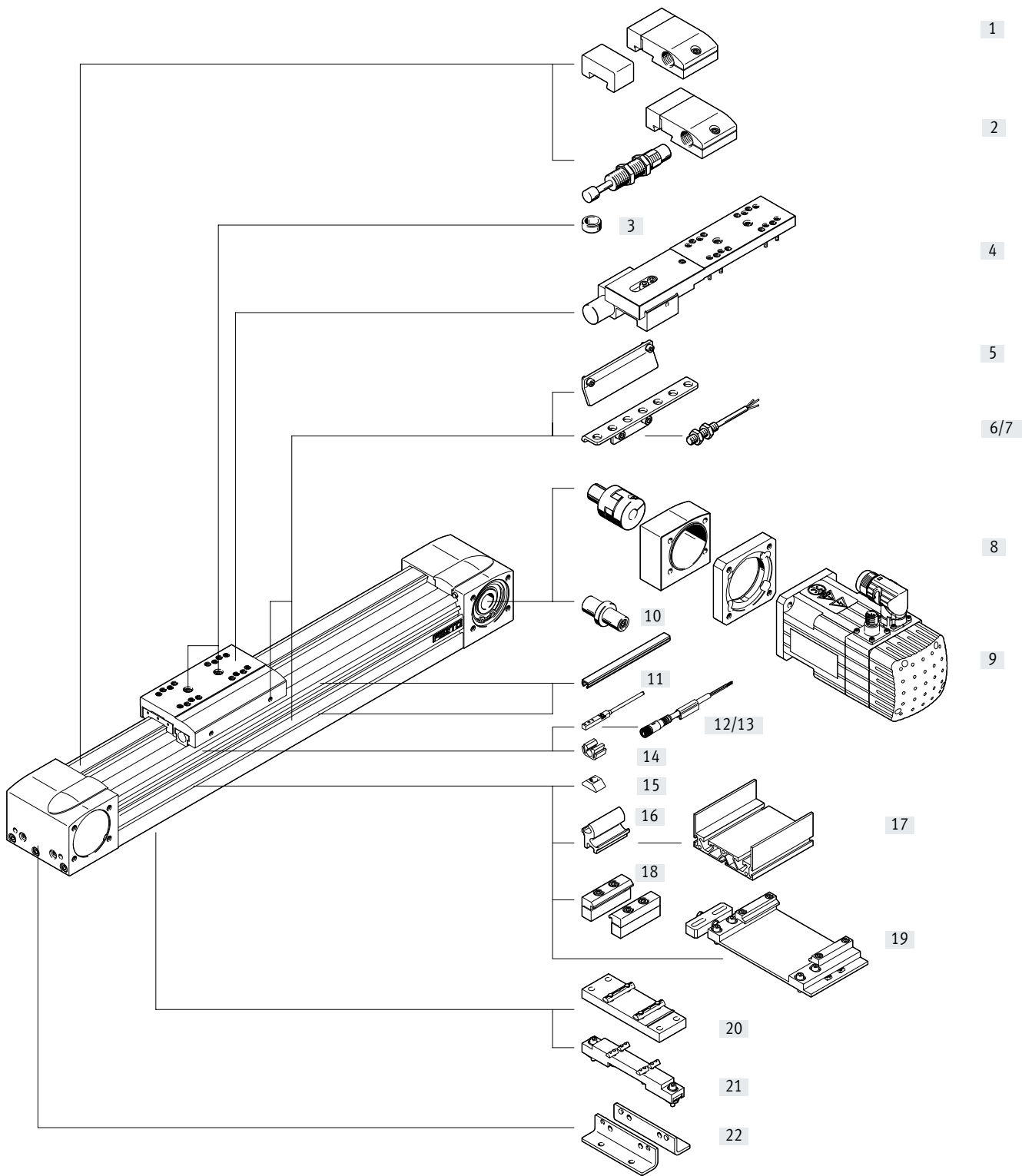

Peripherals overview

Variants and accessories			
Type/order code	Description		→ Page/Internet
[1] Emergency buffer with retaining bracket A	For avoiding damage at the end stop in the event of malfunction		59
[2] Shock absorber with retaining bracket C	For avoiding damage at the end stop in the event of malfunction		59
[3] Centring pin/sleeve ZBS, ZBH	<ul style="list-style-type: none"> For centring loads and attachments on the slide Included in the scope of delivery: <ul style="list-style-type: none"> For size 50, 70: 2x ZBS-5 For size 80, 120, 185: 2x ZBH-9 		59
[4] Clamping unit 1H...PN, 2H-PN	For holding loads		15
[5] Switch lug X, Z, O, P, W, R	For sensing the slide position		56
[6] Sensor bracket O, P, W, R	Adapter for mounting the inductive proximity switches (round design) on the axis		57
[7] Proximity switch, M8 O, P, W, R	<ul style="list-style-type: none"> Inductive proximity switch, round design The order code O, P, W, R includes 1 switch lug and max. 2 sensor brackets in the scope of delivery 		<?>
[8] Axial kit EAMM	For axial motor mounting (comprises: coupling, coupling housing and motor flange)		46
[9] Motor EMME, EMMS	Motors specially matched to the axis, with or without gear unit, with or without brake		46
[10] Drive shaft K	<ul style="list-style-type: none"> Can, if required, be used as an alternative interface No drive shaft is required for the axis/motor combinations → from page 46 onwards 		58
[11] Slot cover B, S	<ul style="list-style-type: none"> For protection against contamination 		59
[12] Proximity switch, T-slot X, Z	<ul style="list-style-type: none"> Inductive proximity switch, for T-slot The order code X, Z includes 1 switch lug in the scope of delivery 		60
[13] Connecting cable V	For proximity switch (order code W and R)		61
[14] Clip CL	For mounting the proximity switch cable in the slot		59
[15] Slot nut Y	For mounting attachments		59
[16] Adapter kit DHAM	For mounting the support profile on the axis		60
[17] Support profile HMIA	For mounting and guiding an energy chain		60
[18] Profile mounting M	For mounting the axis on the side of the profile		52
[19] Adjusting kit EADC-E16	For mounting the axis on a vertical surface. Once mounted, the axis can be aligned horizontally		55
[20] Central support EAHF-L5	For mounting the axis on the profile from underneath		53
[21] Adjusting kit EADC-E15	Is height-adjustable. Can be used to easily compensate for any unevenness in the bearing surface		54
[22] Foot mounting F	For mounting the axis on the end cap		51
- Guide axis EGC-FA	Axis without drive		egc-fa
- Connecting shaft KSK	For connecting two toothed belt axes EGC-TB in 3-dimensional gantries		ksk

Type codes

001	Series	
EGC	Electric linear axis	
002	Size	
50	50	
70	70	
80	80	
120	120	
185	185	
003	Stroke	
300	300	
400	400	
500	500	
600	600	
800	800	
1000	1000	
1200	1200	
1500	1500	
...	50 ... 8500	
004	Drive system	
TB	Toothed belt	
005	Guide	
KF	Recirculating ball bearing guide	
006	Stroke reserve [mm]	
...H	0 ... 999	
007	Slide	
GK	Standard slide	
GP	Standard slide, protected	
GV	Extended slide	
GQ	Extended slide, protected	
008	Additional slide left	
	None	
KL	Additional slide, standard, left	
009	Additional slide, right	
	None	
KR	Additional slide standard, right	
010	Lubrication function	
	None	
C	Lubrication adapter	
011	Displacement encoder	
	None	
M1	With displacement encoder, incremental, resolution 2.5 µm	
M2	With displacement encoder, incremental, resolution 10 µm	
012	Clamping unit	
	None	
1HL	Holding function, 1-channel, left	
1HR	Single-channel holding function, right	
2H	Holding function, 2-channel	
013	Actuation type	
	None	
PN	Pneumatically actuated	

014	Toothed belt material	
	Standard	
PU1	Uncoated PU, FDA-compliant	
PU2	Coated PU	
015	EU certification	
	None	
EX3	II 2G	
016	Foot mounting [units]	
	None	
F	1	
017	Profile mounting	
	None	
...M	1 ... 50	
018	Mounting slot cover, 2x, 500 mm [units]	
	None	
...B	1 ... 50	
019	Cover, sensor slot [units]	
	None	
...S	1 ... 50	
020	Slot nut for mounting slot [units]	
	None	
...Y	1 ... 99	
021	Proximity sensor, inductive, slot 8, PNP, N/O contact, cable 7.5 m [units]	
	None	
...X	1 ... 6	
022	Proximity sensor, inductive, slot 8, PNP, N/C contact, cable 7.5 m [units]	
	None	
...Z	1 ... 6	
023	Emergency buffer with retaining bracket [units]	
	None	
...A	1 ... 2	
024	Shock absorber with retaining bracket [units]	
	None	
...C	1 ... 2	
025	Proximity sensor, inductive, M8, PNP, N/O contact, cable 2.5 m [units]	
	None	
...O	1 ... 99	
026	Proximity sensor, inductive, M8, PNP, N/C contact, cable 2.5 m [units]	
	None	
...P	1 ... 99	
027	Proximity sensor, inductive, M8, PNP, N/C contact, plug M8 [units]	
	None	
...W	1 ... 99	
028	Proximity sensor, inductive, M8, PNP, N/O contact, plug M8 [units]	
	None	
...R	1 ... 99	

Type codes

029	Connecting cable, M8, 2.5 m [units]	
	None	
...V	1 ... 99	



030	Drive shaft [units]	
	None	
...K	1 ... 4	

031	Cable clip [units]	
	None	
...CL	10, 20, 30, 40, 50, 60, 70, 80, 90	

032	Operating instructions	
	With operating instructions	
DN	Without operating instructions	

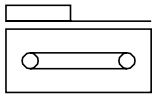
Data sheet



-  Size
50 ... 185
-  Stroke length
50 ... 8500 mm
-  www.festo.com

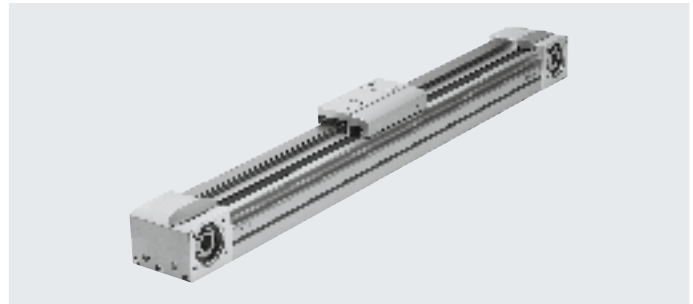

General technical data						
Size		50	70	80	120	185
Design		Electromechanical axis with toothed belt				
Guide		Recirculating ball bearing guide				
Mounting position		Any				
Working stroke						
EGC...-GK/-GP	[mm]	50 ... 1900	50 ... 5000	50 ... 8500	50 ... 8500	50 ... 8500
EGC...-GV/-GQ	[mm]	50 ... 1900	50 ... 5000	50 ... 8500	50 ... 8400	50 ... 8400
Max. feed force F_x	[N]	50	100	350	800	2500
Max. no-load torque ¹⁾	[Nm]	0.072	0.18	0.4	1.4	4.05
Max. no-load resistance to shifting ¹⁾	[N]	8	14.5	28	70	110
Max. driving torque	[Nm]	0.46	1.24	5	16	93
Max. speed	[m/s]	3	5			
Max. acceleration	[m/s ²]	50				
Repetition accuracy	[mm]	±0.08				±0.1

1) At 0.2 m/s, with variant GK or GV

Operating and environmental conditions		
Ambient temperature	[°C]	-10 ... +60
Degree of protection		IP40
Duty cycle	[%]	100

Weights [g]						
Size		50	70	80	120	185
Basic weight with 0 mm stroke ¹⁾						
EGC...-GK/-GP		620	1850	3000	10500	32600
EGC...-GV/-GQ		-	2470	3900	12600	36800
Additional weight per 10 mm stroke		19	44	62	150	300
Moving mass						
EGC...-GK/-GP		130	370	620	2180	6500
EGC...-GV/-GQ		-	550	900	2730	7720
Additional slide						
EGC...-KL/-KR		80	300	550	2000	6000
Clamping unit						
EGC...-1H...-PN		-	-	700	2300	4900
EGC...-2H-PN		-	-	1300	4000	8300

1) Incl. slide

Data sheet

ATEX ¹⁾		50	70	80	120
Size					
ATEX category for gas		II 2G			
Type of ignition protection for gas		c IIB T4 X			
Explosion-proof ambient temperature		-10°C ≤ Ta ≤ +60°C			
CE marking (see declaration of conformity)		To EU Explosion Protection Directive (ATEX)			

1) Note the ATEX certification of the accessories.

Toothed belt		50	70	80	120	185
Size						
Pitch	[mm]	2	3	3	5	8
Elongation ¹⁾						
EGC-...	[%]	0.125	0.08	0.213	0.168	0.24
EGC-...-PU2	[%]	-	0.041	0.105	0.1	0.095
Width	[mm]	10	15	19.3	30.3	50.5
Effective diameter	[mm]	18.46	24.83	28.65	39.79	73.85
Feed constant	[mm/rev]	58	78	90	125	232

1) At max. feed force

Mass moment of inertia		50	70	80	120	185
Size						
J ₀						
EGC-...-GK	[kg mm ²]	16.94	83.34	205.9	1241	17976
EGC-...-GV	[kg mm ²]	-	110	265	1465	19690
J _H per metre stroke	[kg mm ² /m]	2.6	10.6	18.8	93	760
J _L per kg payload	[kg mm ² /kg]	85	154	205	396	1363.5
J _W Additional slide	[kg mm ²]	3.56	56.32	126.73	861	8846
J _F Clamping unit						
EGC-...-1H...-PN	[kg mm ²]	-	-	143.5	911	6681
EGC-...-2H...-PN	[kg mm ²]	-	-	266.5	1584	11317

The mass moment of inertia J_A of the entire axis is calculated as follows:

$$J_A = J_0 + K \times J_W + J_H \times \text{working stroke [m]} + J_L \times m_{\text{payload [kg]}} + J_F$$

K= Number of additional slides

Data sheet

Materials

Sectional view

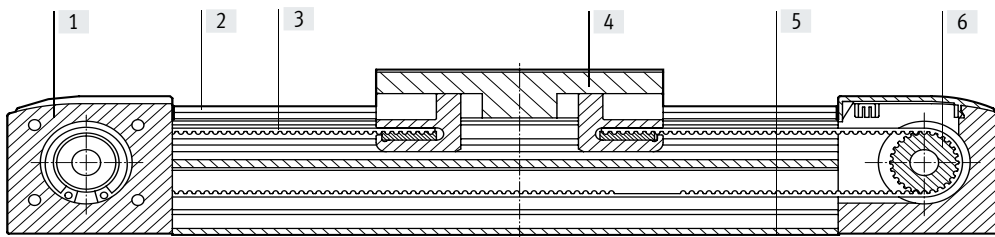

Size	50	70	80	120	185
[1] Drive cover	Anodised wrought aluminium alloy				Painted wrought aluminium alloy
[2] Guide rail	High-alloy steel				
[3] Toothed belt					
EGC-...	Polychloroprene with glass cord and nylon coating				
EGC-...-PU2	Polyurethane with steel cord and nylon covering				
[4] Slide	Anodised wrought aluminium alloy				
[5] Profile	Anodised wrought aluminium alloy				
[6] Toothed belt pulley	High-alloy stainless steel				
Note on materials	RoHS-compliant				
	Contains paint-wetting impairment substances				

Technical data – Displacement encoder

Dimensions → Page 40

Type	EGC-...-M1	EGC-...-M2
Resolution [µm]	2.5	10
Max. travel speed with displacement encoder [m/s]	4	4
Encoder signal	5 V TTL; A/A, B/B; reference signal (N/N) cyclical every 5 mm (zero pulse)	
Signal output	Line driver, alternating, resistant to sustained short circuit	
Electrical connection	8-pin plug, round design, M12	
Cable length [mm]	160	

Operating and environmental conditions – Displacement encoder

Ambient temperature [°C]	-10 ... +70
Degree of protection	IP64
CE marking (see declaration of conformity)	In accordance with EU EMC Directive ¹⁾

- 1) For information about the area of use, see the EC declaration of conformity at: www.festo.com/sp → Certificates.
If the devices are subject to usage restrictions in residential, commercial or light-industrial environments, further measures for the reduction of the emitted interference may be necessary.

Note regarding use

The toothed belt axis with displacement encoder is not designed for the following application examples

- Magnetic field

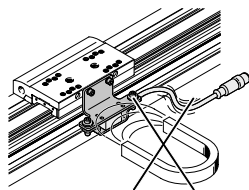

- Welding application

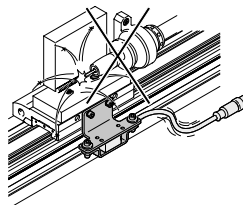

Data sheet

Technical data – Clamping unit		Dimensions → Page 36		
Size		80	120	185
Pneumatic connection		M5	M5	M5
Clamping type		Clamping via spring force, compressed air to release		
Static holding force				
EGC-...-1H...-PN	[N]	320	1200	1500
EGC-...-2H...-PN	[N]	640	2400	3000
Max. number of emergency braking operations ¹⁾ at reference energy	[J]	–	750 35	750 70
Number of clamping operations under rated load	[millions of switching cycles]	0.45	0.05	, 1.4

1) Emergency braking refers to braking the payload if the drive axis loses power.

Operating and environmental conditions – Clamping unit	
Operating medium	Compressed air to ISO 8573-1:2010 [7:4:4]
Operating pressure	
Clamping unit open	[bar] 4.5 ... 8
Clamping unit closed	[bar] Unpressurised
Ambient temperature	[°C] –10 ... +60

 **Note**

The axis can only be relubricated with the lubrication adapter (EGC-...-C) when used in combination with the clamping unit.

Data sheet

Characteristic load values

The indicated forces and torques refer to the slide surface. The point of application of force is the point where the centre of the guide and the longitudinal centre of the slide intersect. These values must not be exceeded during dynamic operation. Special attention must be paid to the deceleration phase.

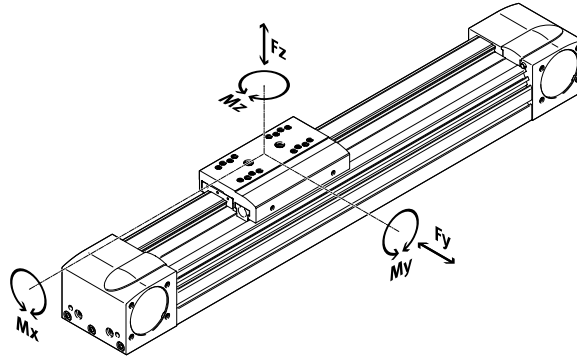

Max. permissible forces and torques for a service life of 5000 km

Size	50	70	80	120	185
F _y _{max.} [N]	650	1850	3050	6890	15200
F _z _{max.} [N]	650	1850	3050	6890	15200
M _x _{max.} [Nm]	3.5	16	36	144	529
M _y _{max.} /M _z _{max.}					
EGC-...-GK/-GP [Nm]	10	51	97	380	1157
M _y _{max.} /M _z _{max.}					
EGC-...-GV/-GQ [Nm]	-	132	228	680	1820

Note

For a guide system to have a service life of 5000 km, the load comparison factor must have a value of $f_v \leq 1$, based on the maximum permissible forces and torques for a service life of 5000 km.

If the axis is subjected to two or more of the indicated forces and torques simultaneously, the following equation must be satisfied in addition to the indicated maximum loads:

Calculating the load comparison factor:

$$f_v = \frac{|F_{y1}|}{F_{y2}} + \frac{|F_{z1}|}{F_{z2}} + \frac{|M_{x1}|}{M_{x2}} + \frac{|M_{y1}|}{M_{y2}} + \frac{|M_{z1}|}{M_{z2}} \leq 1$$

F₁/M₁ = dynamic value

F₂/M₂ = maximum value

Data sheet

Calculating the service life

The service life of the guide depends on the load. To be able to make a statement as to the service life of the guide, the graph below plots the load comparison factor f_v against the service life.

These values are only theoretical. You must consult your local Festo contact for a load comparison factor f_v greater than 1.5.

Load comparison factor f_v as a function of service life

Example:

A user wants to move an X kg load. Using the formula (→ page 16) gives a value of 1.5 for the load comparison factor f_v . According to the graph, the guide would have a service life of approx. 1500 km. Reducing the acceleration reduces the M_z and M_y values. A load comparison factor f_v of 1 now gives a service life of 5000 km.

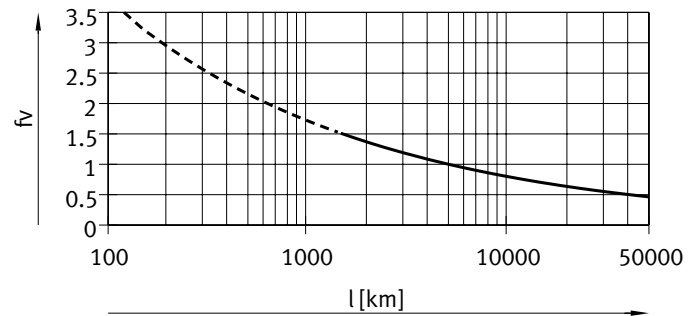

Note

Engineering software
PositioningDrives
www.festo.com

The software can be used to calculate a guide workload for a service life of 5000 km.

$f_v > 1.5$ are only theoretical comparison values for the recirculating ball bearing guide.

Comparison of the characteristic load values for 5000 km with dynamic forces and torques of recirculating ball bearing guides

The characteristic load values of bearing guides are standardised to ISO and JIS using dynamic and static forces and torques. These forces and torques are based on an expected service life of the guide system of 100 km according to ISO or 50 km according to JIS.

As the characteristic load values are dependent on the service life, the maximum permissible forces and torques for a 5000 km service life cannot be compared with the dynamic forces and torques of bearing guides to ISO/JIS.

To make it easier to compare the guide capacity of linear axes EGC with bearing guides, the table below lists the theoretically permissible forces and torques for a calculated service life of 100 km. This corresponds to the dynamic forces and torques to ISO.

These 100 km values have been calculated mathematically and are only to be used for comparing with dynamic forces and torques to ISO. The drives must not be loaded with these characteristic values as this could damage the axes.

Max. permissible forces and torques for a theoretical service life of 100 km (from a guide perspective only)

Size		50	70	80	120	185
$F_{y_{max}}$	[N]	2395	6815	11236	25383	55997
$F_{z_{max}}$	[N]	2395	6815	11236	25383	55997
$M_{x_{max}}$	[Nm]	13	59	133	531	1949
$M_{y_{max}}/M_{z_{max}}$						
EGC...-GK/-GP	[Nm]	37	188	357	1400	4262
$M_{y_{max}}/M_{z_{max}}$						
EGC...-GV/-GQ	[Nm]	-	486	840	2505	6705

Data sheet

Max. acceleration a as a function of payload m

Size 50

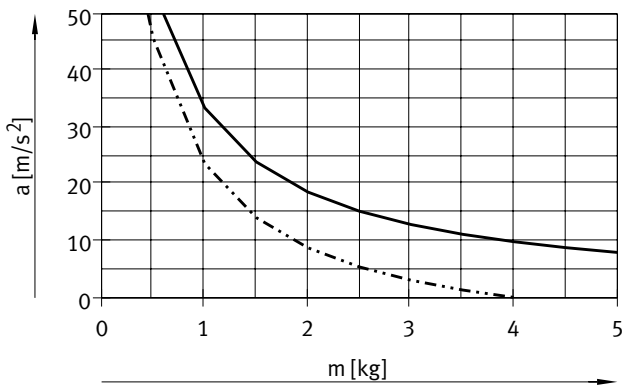

Size 70

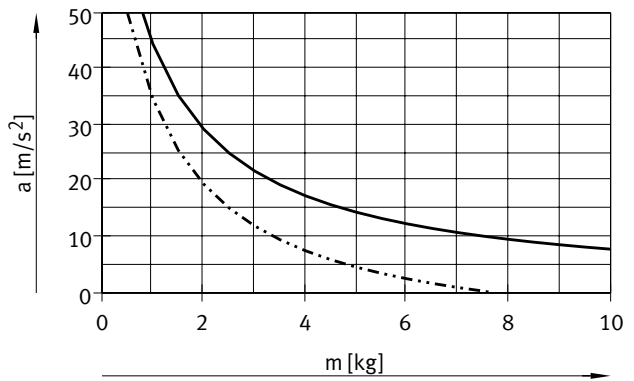

Size 80

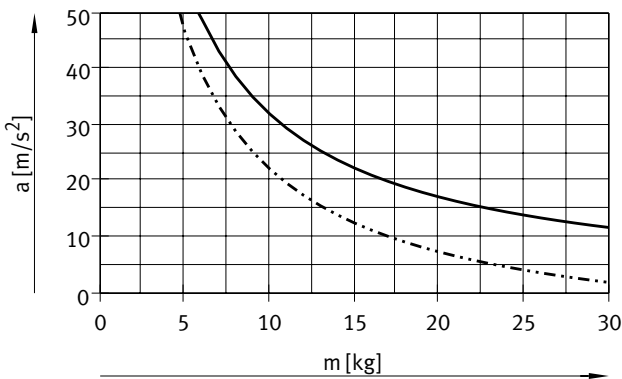

Size 120

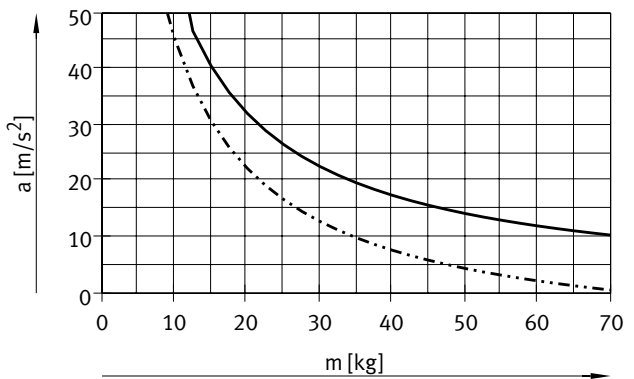

Size 185

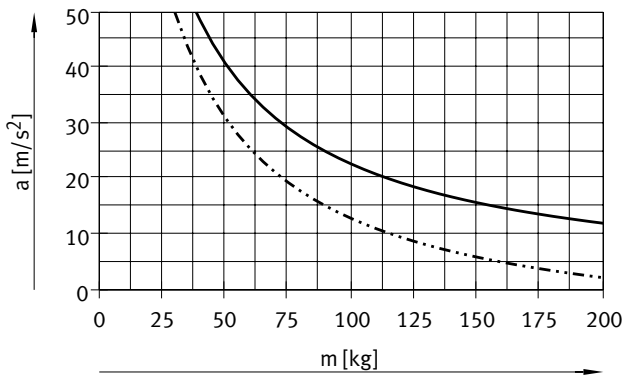

— Horizontal mounting position
 - - - Vertical mounting position

Data sheet

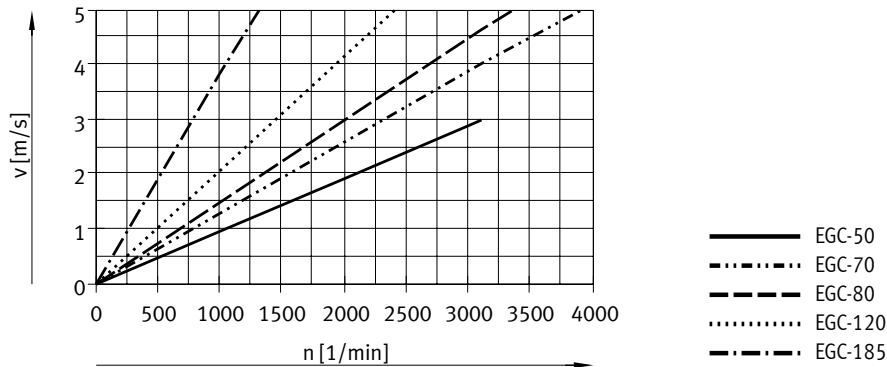
Speed v as a function of rotational speed n Theoretical feed force F as a function of input torque M

Size 50/70

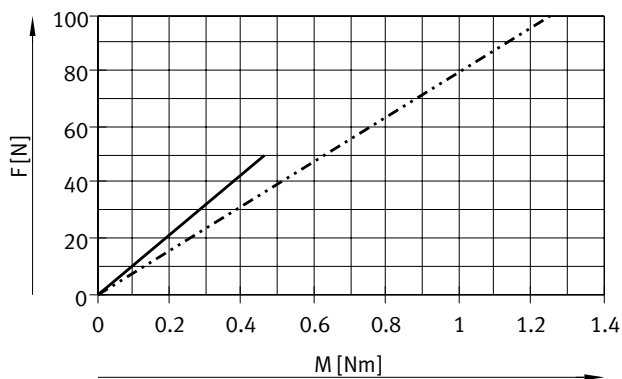

Size 80/120

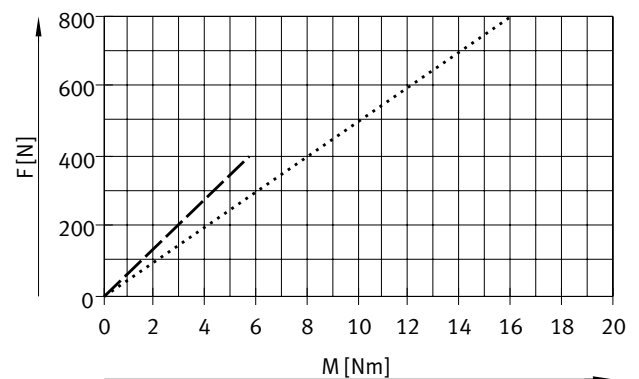

Size 185

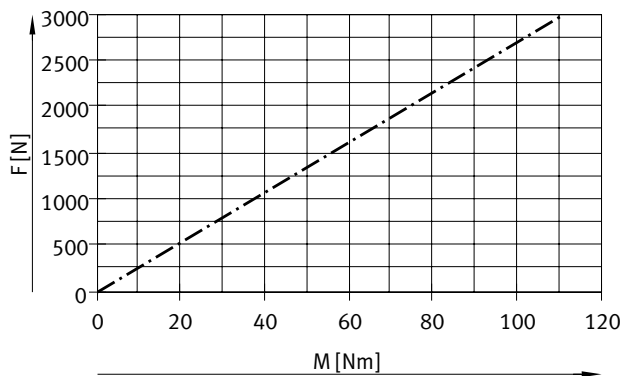

Data sheet

Stroke reserve

Stroke length	Stroke reserve
---------------	----------------

The selected stroke corresponds in principle to the required working stroke. The variants GK/GV do not have a wiper seal on the guide. These variants therefore have an additional safety distance between the drive cover and slide that is not designated as part of the working stroke.

A safety distance (similar to GK/GV) between the drive cover and slide can be defined for the variants GP/GQ and GK-C/GV-C using the modular product system via the "stroke reserve" characteristic. With the variants GK/GV, the stroke reserve and safety distance are added for each end position.

- The stroke reserve length can be freely selected
- The sum of the stroke length and 2x stroke reserve must not exceed the maximum working stroke

Example:

EGC-70-500-TB-KF-20H-...
 Working stroke = 500 mm
 2x stroke reserve = 40 mm
 Total stroke = 540 mm
 (540 mm = 500 mm + 2x 20 mm)

Size	50	70	80	120	185
L9 = safety distance with GK/GV [mm] (per end position)	-	10.5	13	18	21

Working stroke reduction

With standard slide GK/GP / extended slide GV/GQ with additional slide KL/KR

- For a toothed belt axis with additional slide, the working stroke is reduced by the length of the additional slide and the distance between the two slides
- If the variant GP/GQ is ordered, the additional slide is also protected
- If the variant GV/GQ is ordered, the additional slide is not extended
- If the variant GK-C/GV-C is ordered, the additional slide is also supplied with lubrication adapters

L16 = Slide length
 L17 = Additional slide length
 L18 = Distance between both slides
 [1] Additional slide

Example:

Type EGC-70-500-TB-...-GK-KR
 Working stroke without additional slide = 500 mm
 L18 = 20 mm
 L16, L17 = 100 mm
 Working stroke with additional slide = 380 mm
 (500 mm - 20 mm - 100 mm)

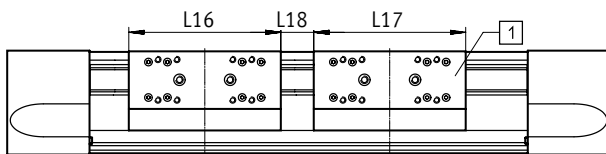

Dimensions – Additional slide

Size	50	70	80	120	185				
Variant	GK/GV	GK/GV	GP/GQ	GK/GV	GP/GQ or GK-C/GV-C	GK/GV	GP/GQ or GK-C/GV-C	GK/GV	GK-C/GV-C
Length L17 [mm]	65	100	121	120	146	203.3	236	282.8	322
Min. distance between the slides L18 [mm]	-	-	21	-	26	-	36	-	42

Data sheet

Working stroke reduction per side

With integrated emergency buffer NPE / shock absorber YSRW with shock absorber retainer KYE

- The working stroke is reduced by the total dimension of the emergency buffer/shock absorber and shock absorber retainer.
- The rubber buffer in the cover must be removed.
- Shock absorbers must not be used in combination with lubrication adapters.

Size		50	70	80	120	185
With emergency buffer	[mm]	30	43	68	98	133
With shock absorber	[mm]	26	42	63	84	107

Working stroke reduction

With integrated clamping unit

- The working stroke is reduced by the length of the clamping unit.
- With 1-channel clamping units, the stroke is reduced on one side with respect to the mounting surface
- With 2-channel clamping units, the stroke is reduced symmetrically with respect to the mounting surface of the load
- Shock absorbers must not be used in combination with the clamping unit.

Size		80	120	185
EGC-...-1H-...-PN	[mm]	87	124	131
EGC-...-2H-...-PN	[mm]	174	248	262

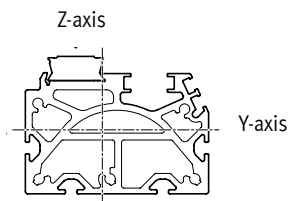
2nd moments of area

Size		50	70	80	120	185
I _y	[mm ⁴]	8.4x10 ⁴	3.95x10 ⁵	8.44x10 ⁵	4.62x10 ⁶	2.34x10 ⁷
I _z	[mm ⁴]	1.14x10 ⁵	5.77x10 ⁵	1.16x10 ⁶	5.65x10 ⁶	2.74x10 ⁷

Data sheet

Maximum permissible support spacing L (without profile mounting MUE/central support EAHF) as a function of force F

In order to limit deflection in the case of large strokes, the axis may need to be supported.

The following graphs can be used to determine the maximum permissible support span l as a function of force F acting on the axis. The deflection is $f = 0.5$ mm.

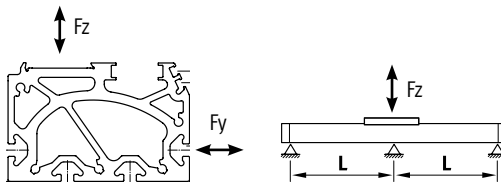

Force F_y

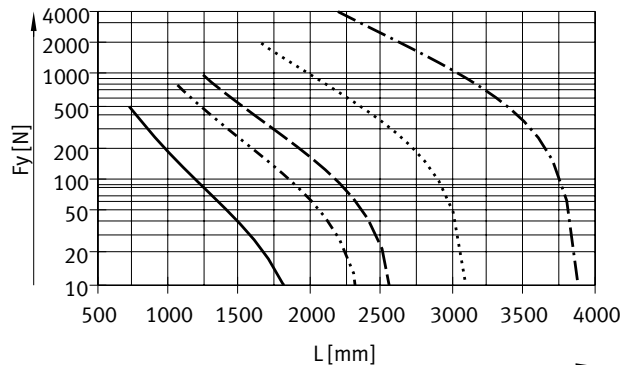

- EGC-50
- EGC-70
- - - EGC-80
- · - · EGC-120
- - - - EGC-185

Force F_z

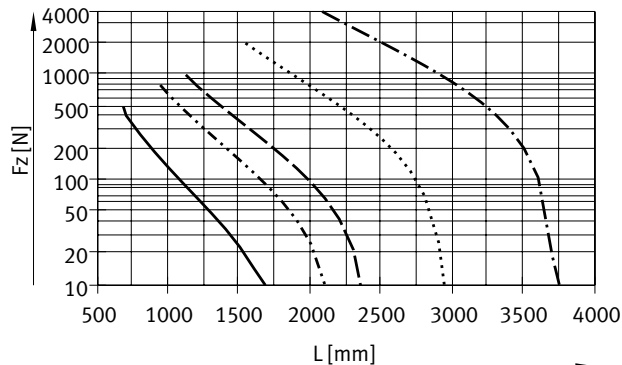

Recommended deflection limits

Adherence to the following deflection limits is recommended so as not to impair the functionality of the axes. Greater deformation can result in increased friction, greater wear and reduced service life.

Size	Dynamic deflection (moving load)	Static deflection (stationary load)
50 ... 185	0.05% of the axis length, max. 0.5 mm	0.1% of the axis length

Data sheet

Central lubrication

The lubrication adapter enables the guide of the toothed belt axis EGC-TB to be permanently lubricated in applications in humid or wet ambient conditions using semi or fully automatic relubrication devices.

- For size 80, 120, 185
- The modules are suitable for oils and greases.
- The dimensions of the toothed belt axis EGC-TB are the same with and without central lubrication modules.
- Both lubrication adapters must be connected
- There are three connection options on each side
- Can be used in combination with:
 - Standard slide GK
 - Additional slide KL, KR
- Cannot be used in combination with:
 - Protected recirculating ball bearing guide GP

Slide dimensions

→ Page 31

Order code C in the modular product system → Page 44

Connection options

Only the connection at the rear or on the top can be used in combination with shock absorbers in the end caps

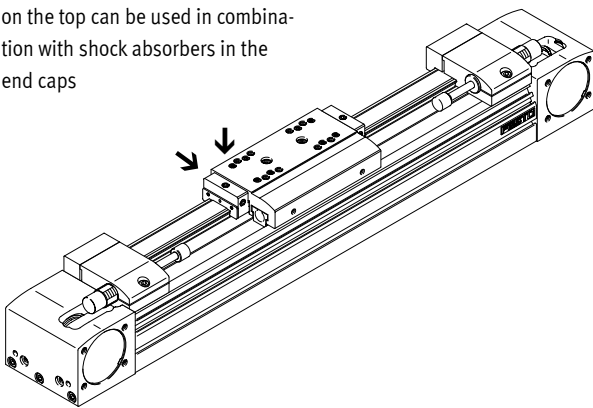

Connection option for customer design

The drawing opposite shows the connection option on the top lubrication interface using a customer design.

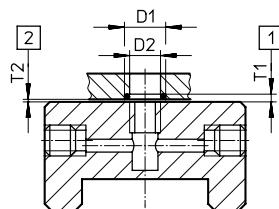

D1 $8^{+0.2}$ mm

D2 6 mm

T1 $0.6_{-0.05}$ mm

T2 $0.1^{+0.2}$ mm

O-ring diameter 6x1 mm (DIN3771)

[1] Slot depth for O-ring

[2] Required air gap

Additional dimensions → Page 31

Structure of a central lubrication system

A central lubrication system requires various additional components. The illustration shows different options (using a hand pump, pneumatic container pump or electric container pump) required as a minimum for designing a central lubrication system. Festo does not sell these additional components; however, they can be obtained from the following companies:

- Lincoln
- Bielomatik
- SKF (Vogel)

Festo recommends these companies because they can supply all the necessary components.

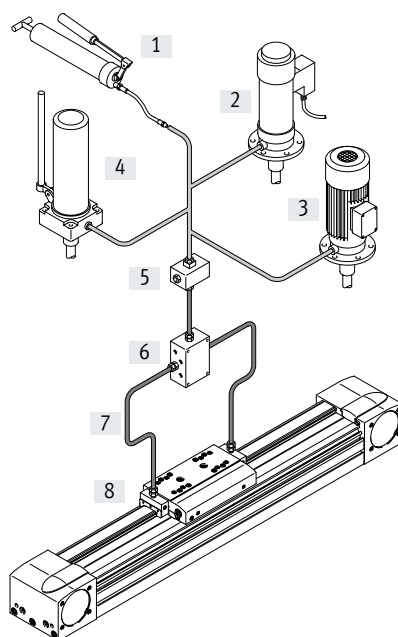

[1] Hand pump

[2] Pneumatic container pump

[3] Electric container pump

[4] Manually operated container pump

[5] Nipple block

[6] Distributor block

[7] Tubing or piping

[8] Fittings

Data sheet

Dimensions

Download CAD data → www.festo.com

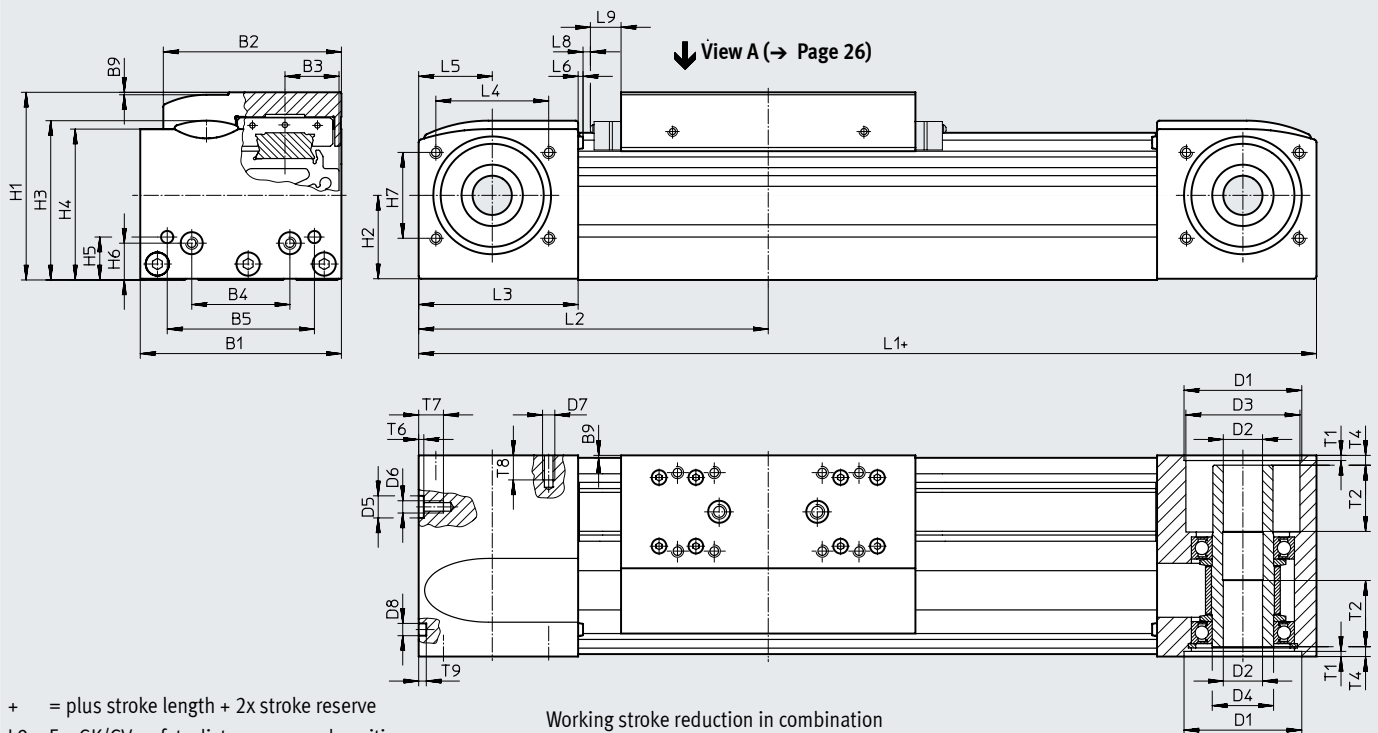

+ = plus stroke length + 2x stroke reserve
 L9 For GK/GV: safety distance per end position
 For GP/GQ: dimension for wiper seal → Page 20
 For GK-C/GV-C: dimension for adapter → Page 31

Working stroke reduction in combination with additional slide → Page 20

Size	B1	B2	B3	B4	B5	B9	D1	D2	D3	D4	D5	D6
							H7	∅ H7	∅	∅	∅ H7	
50	48	39	11.5	20	35	1	27	8	20	15	-	M4
70	69	58.6	16.5	30	45	1	38	10	28	20	-	M5
80	82	72.6	22	40	60	1	48	16	46.5	25	9	M5
120	120	107	33	80	40	1	62	23	59	35	-	M8
185	186	169	53	120	80	1	95	32	90	60	-	M10

Size	D7	D8 ∅ H7	H1	H2	H3	H4	H5	H6	H7	L1		L2	
										GK	GV	GK	GV
50	M3	5	42.5	16.5	37.6	35.5	10.5	10.5	18	155	-	77.5	-
70	M5	5	64	28	53.7	50.8	13	13	29	246	346	123	173
80	M5	5	76.5	34.5	65	61.5	17.5	15	35	286	386	143	193
120	M6	9	111.5	51.6	95.9	91.1	22	22	54	446	546	223	273
185	M8	9	172.5	80.5	152.6	143	25	25	80	612	712	306	356

Size	L3	L4	L5	L6	L8	L9	T1	T2	T4	T6	T7	T8	T9
50	40	26	20	1.8	3	-	1.5	-	5.9	-	7	8	3.1
70	57.5	36	27.5	1.8	3	10.5	2.1	18	7.15	-	10	12	3.1
80	65	46	30	2	3	13	2.1	27	4	2.1	10	10	3.1
120	100	64	50	2	3	18	3.1	29.5	4	-	16	14	2.1
185	140	80	70	2	3	21	2.8	34.5	4	-	20	17	2.1

Data sheet

Profile

Size 50

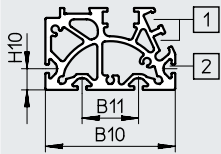

Size 70

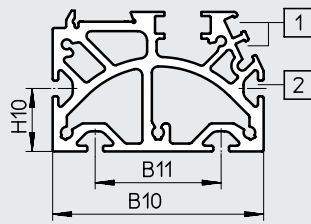

Size 80

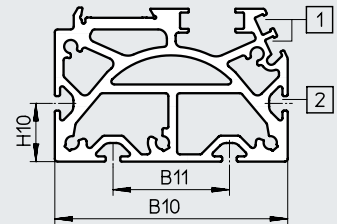

Size 120

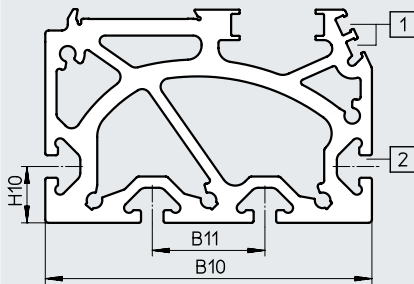

Size 185

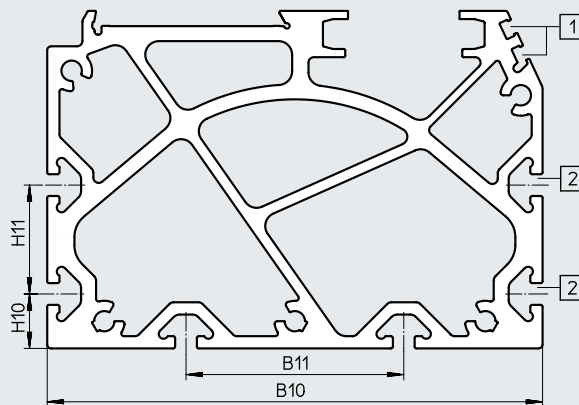

- [1] Sensor slot for proximity switch
[2] Mounting slot for slot nut

Size	B10	B11	H10	H11
50	46	20	7.5	-
70	67	40	20	-
80	80	40	20	-
120	116	40	20	-
185	182	80	20	40

Note

Requirements for the flatness of the bearing surface and of attachments as well as for use in parallel structures can be found at www.festo.com/sp → User documentation

Data sheet

Dimensions

Download CAD data → www.festo.com

GK – Standard slide / GP – Standard slide, protected

Size 50

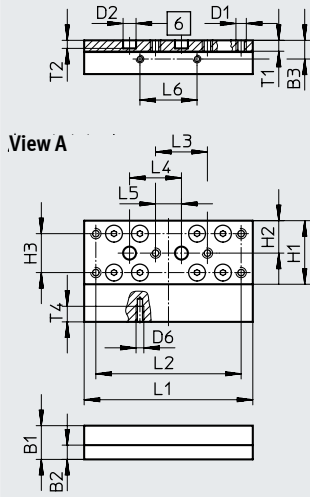

Size 70

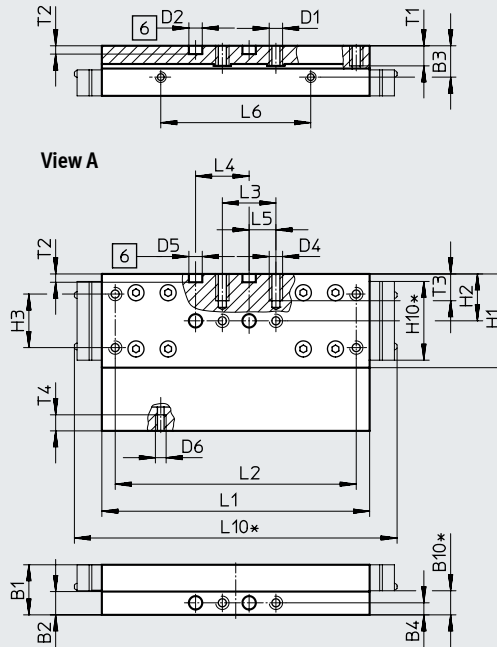

Size 80

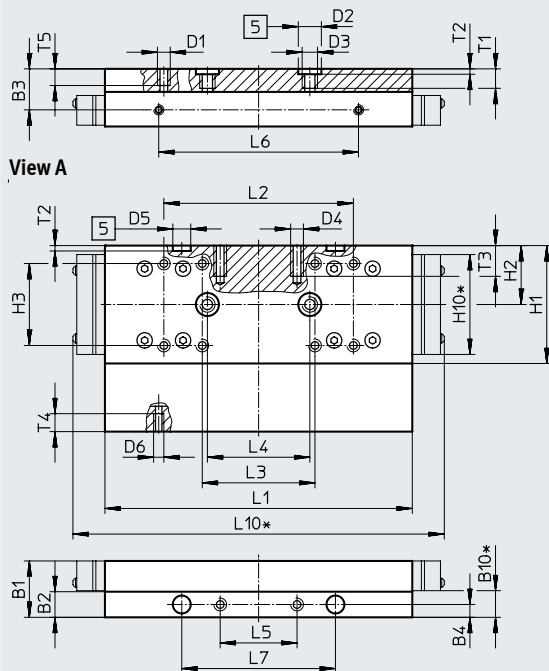

Size 120

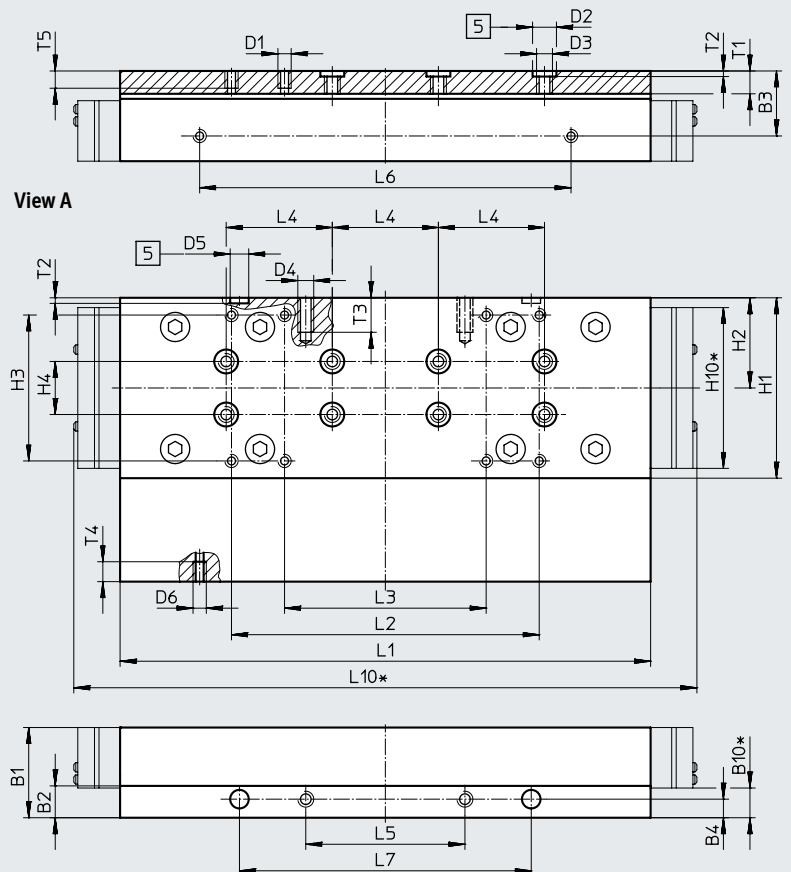

[5] Drill hole for centring sleeve

[6] Drill hole for centring pin

* Protected version

Data sheet

Dimensions

Download CAD data → www.festo.com

GK – Standard slide

Size 185

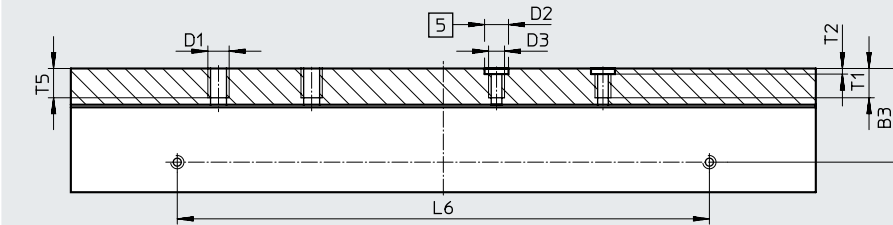

View A

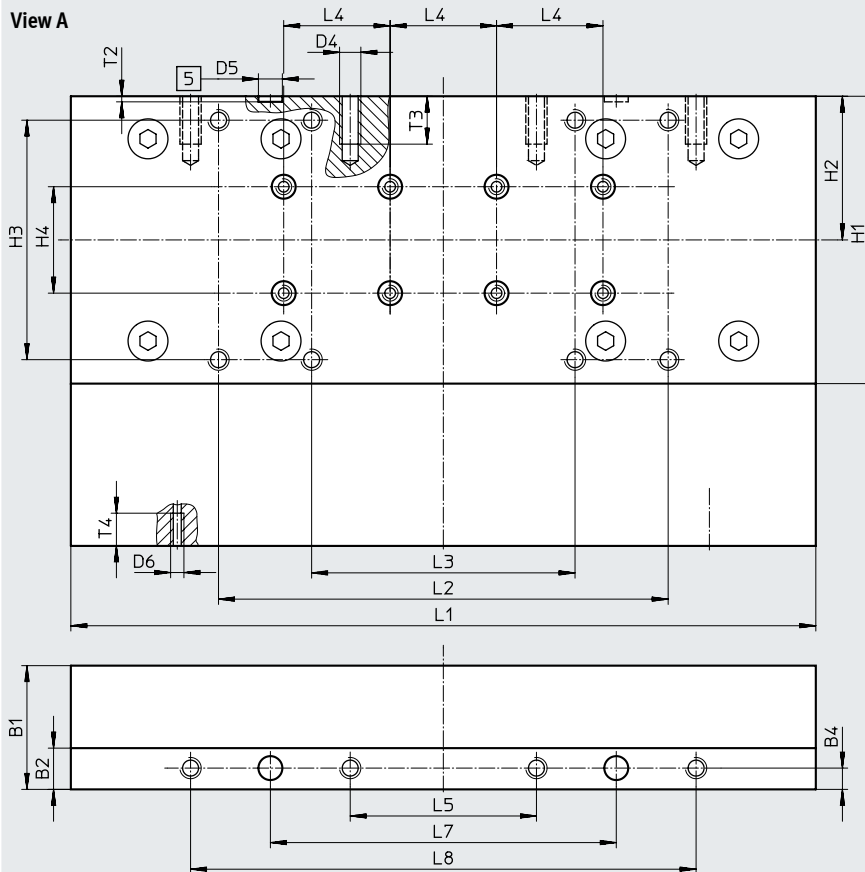

[5] Drill hole for centring sleeve

Size	B1	B2	B3	B4	B10*	D1	D2 ∅ H7	D3	D4	D5 ∅ H7	D6	H1	H2	H3	H4 ±0.03
50	13	5.5	7.2	–	–	M4	5	–	–	–	M3	24.5	12.5	15 ±0.1	–
70	18.7	8.7	11.7	4.5	9	M5	5	–	M5	5	M4	35	17.5	20 ±0.1	–
80	22	10	16	5	10.4	M5	9	M6	M5	7	M4	46	23	32 ±0.2	–
120	34	12	24.5	7	11.2	M5	9	M6	M6	7	M5	68	34	55 ±0.2	20
185	46.5	15.5	35.2	8	–	M8	9	M6	M8	9	M5	108	54	90 ±0.2	40

Size	H10*	L1	L2	L3	L4 ±0.03	L5	L6 ±0.1	L7 ±0.05	L8 ±0.2	L10*	T1	T2 +0.1	T3	T4	T5
50	–	65	56 ±0.1	20 ±0.1	20	10 ±0.1	22	–	–	–	4.2	3.1	–	6	–
70	29.4	100	90 ±0.1	20 ±0.1	20	10 ±0.1	56	–	–	121	7.5	3.1	10	6	–
80	39	120	74 ±0.2	44 ±0.2	40	30 ±0.1	78	60	–	145	8.6	2.1	12	7	7.5
120	60.6	203.3	116 ±0.2	76 ±0.2	40	60 ±0.1	140	110	–	235	8.6	2.1	13	7.5	7.5
185	–	282.8	169 ±0.2	99 ±0.2	40	70 ±0.2	200	130	190	–	11	2.1	18	12.3	12

* Protected version

Data sheet

Dimensions

Download CAD data → www.festo.com

GV – Extended slide / GQ – Extended slide, protected

Size 80

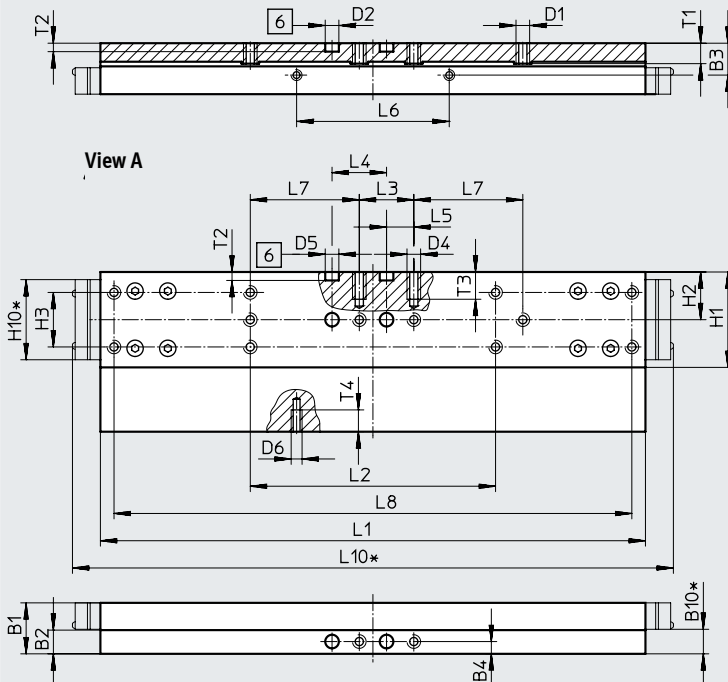

Size 80

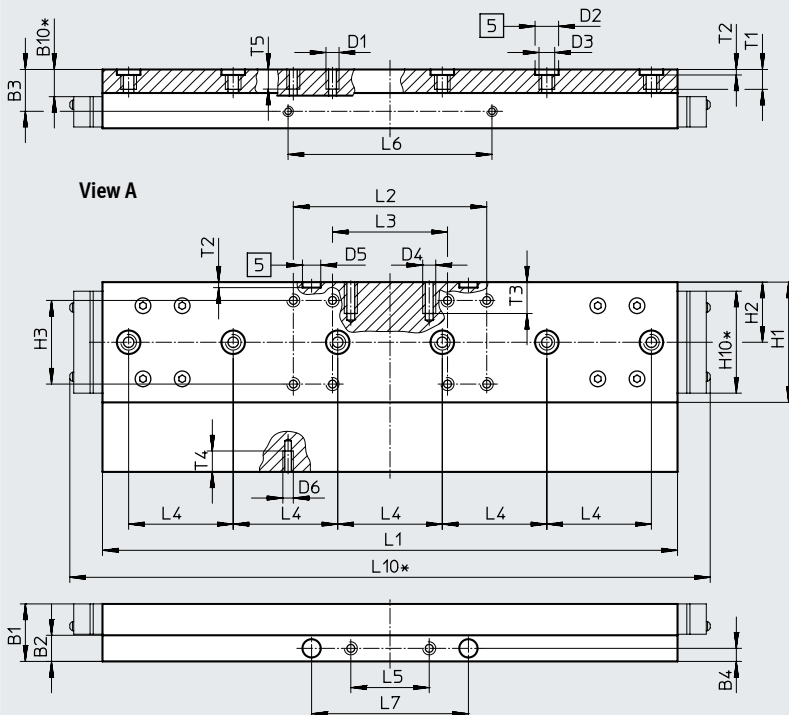

- [5] Drill hole for centring sleeve
- [6] Drill hole for centring pin
- * Protected version

Data sheet

Dimensions

Download CAD data → www.festo.com

GV – Extended slide / GQ – Extended slide, protected

Size 120

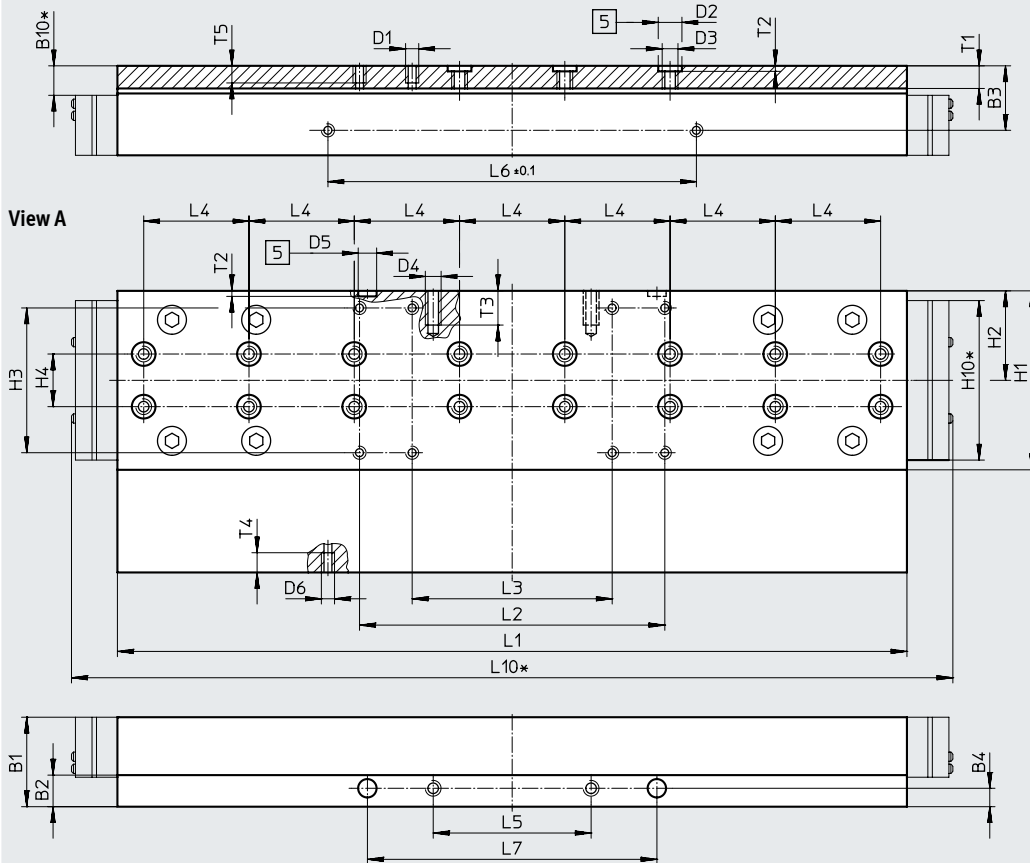

[5] Drill hole for centring sleeve
* Protected version

Size	B1	B2	B3	B4	B10*	D1	D2 ∅ H7	D3	D4	D5 ∅ H7
70	18.7	8.7	11.7	4.5	9	M5	5	–	M5	5
80	22	10	16	5	10.4	M5	9	M6	M5	7
120	34	12	24.5	7	11.2	M5	9	M6	M6	7

Size	D6	H1	H2	H3	H4	H10*	L1	L2	L3	L4
					±0.03		±0.1			±0.03
70	M4	35	17.5	20 ±0.1	–	29.4	200	90 ±0.1	20 ±0.1	20
80	M4	46	23	32 ±0.2	–	39	220	74 ±0.2	44 ±0.2	40
120	M5	68	34	55 ±0.2	20	60.6	303.3	116 ±0.2	76 ±0.2	40

Size	L5	L6	L7	L8	L10*	T1	T2	T3	T4	T5
	±0.1	±0.1		±0.2			+0.1			
70	10	56	40 ±0.1	190	221	7.5	3.1	10	6	–
80	30	78	60 ±0.05	–	245	8.6	2.1	12	7	7.5
120	60	140	110 ±0.05	–	335	8.6	2.1	13	7.5	7.5

* Protected version

Data sheet

Dimensions

Download CAD data → www.festo.com

GV – Extended slide

Size 185

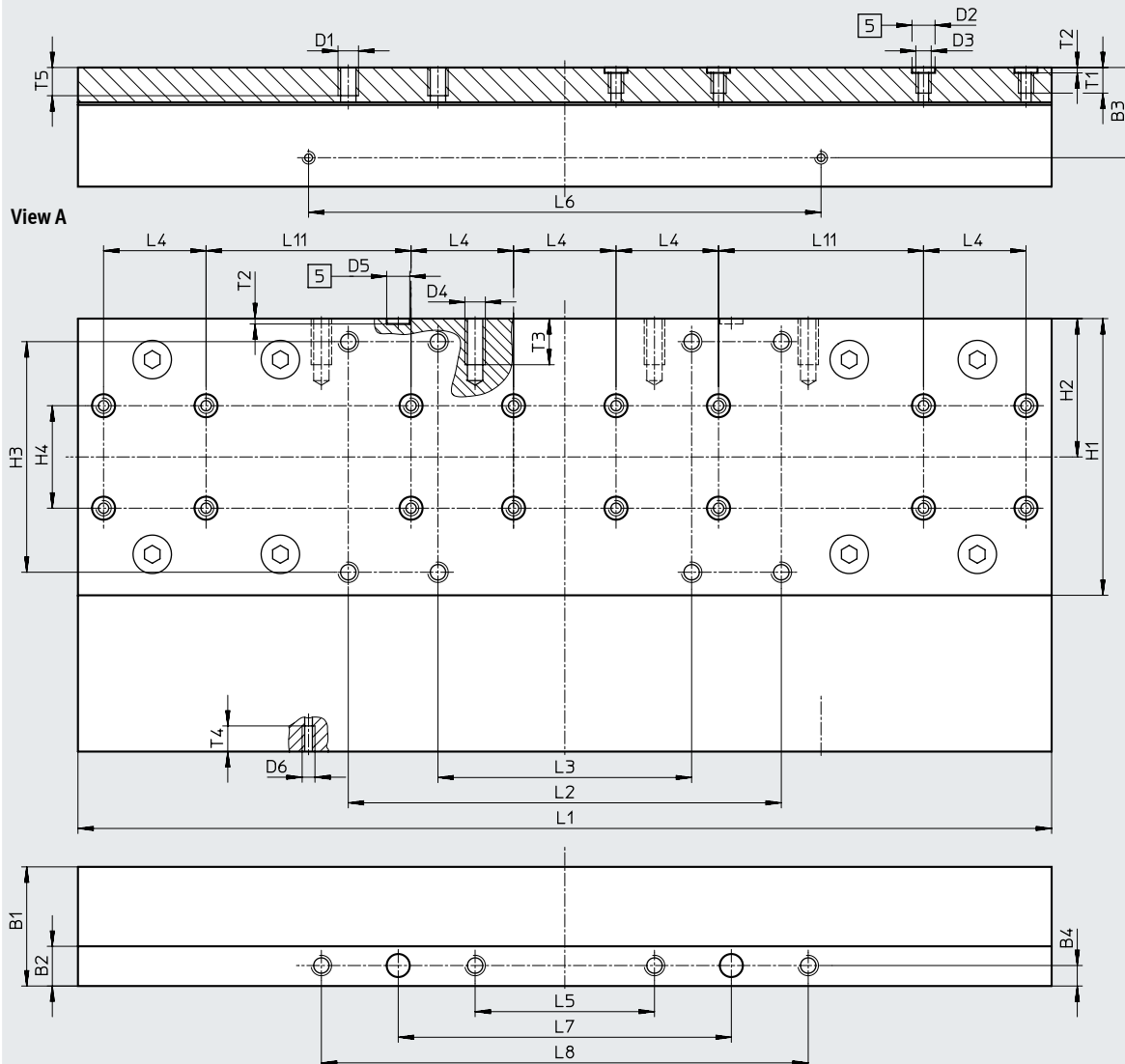

[5] Drill hole for centring sleeve

Size	B1	B2	B3	B4	D1	D2 ∅ H7	D3	D4	D5 ∅ H7
185	46.5	15.5	35.2	8	M8	9	M6	M8	9

Size	D6	H1	H2	H3	H4	L1	L2	L3	L4
185	M5	108	54	±0.2	±0.03	±0.1	±0.2	±0.2	±0.03

Size	L5	L6	L7	L8	L11	T1	T2	T3	T4	T5
185	±0.2	±0.1	±0.05	±0.2	±0.03		+0.1			
185	70	200	130	190	80	11	2.1	18	10	12

Data sheet

Dimensions

Download CAD data → www.festo.com

GK-C – Standard slide with lubrication adapter

Size 80

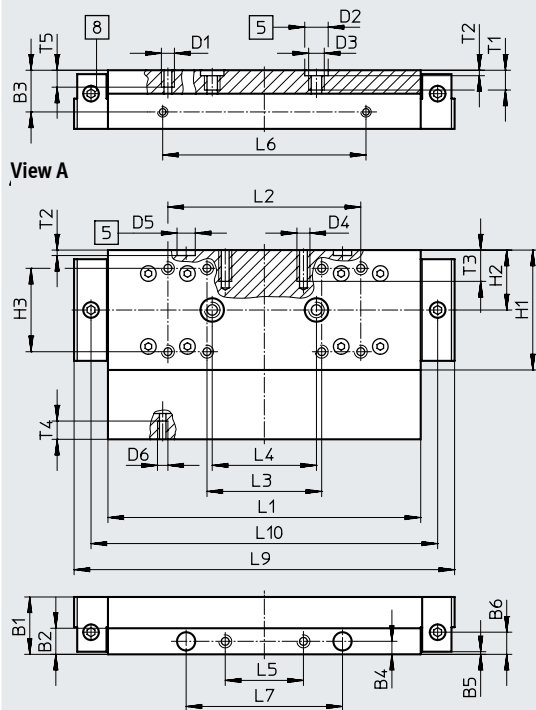

- [5] Drill hole for centring sleeve
- [8] Lubricating hole for lubrication adapter
M6 threaded connection, 6 mm deep

Size 120

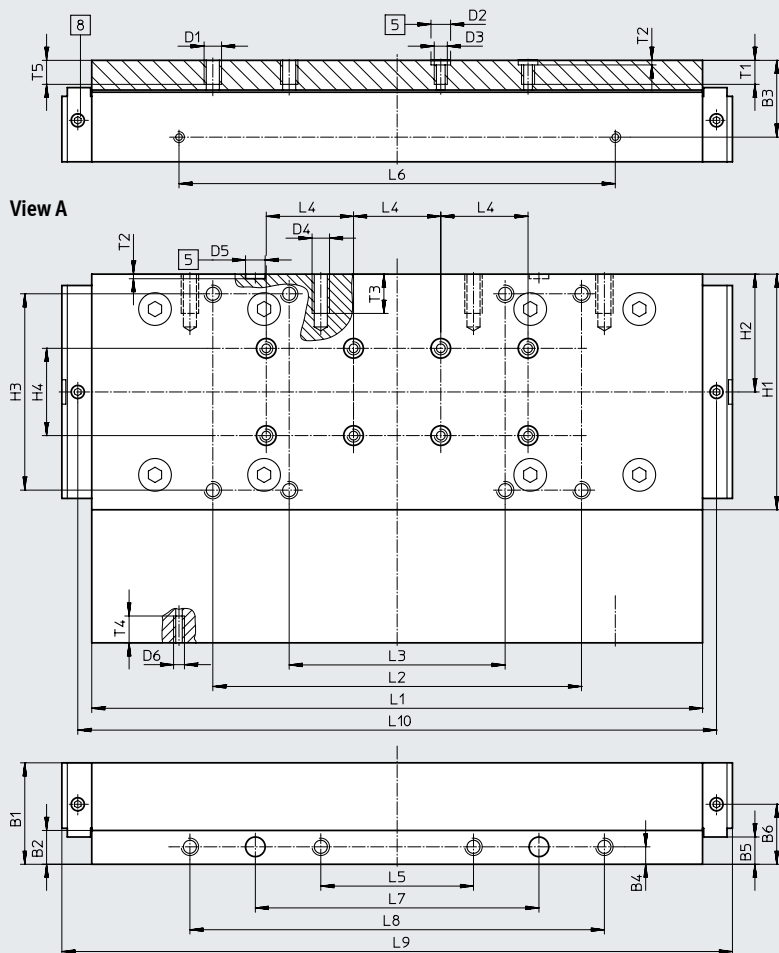

Size	B1	B2	B3	B4	B5	B6	D1	D2 ∅ H7	D3	D4
80	22	10	16	5	±0.1	8.5	M5	9	M6	M5
120	34	12	24.5	7	5.5	18.2	M5	9	M6	M6

Size	D5 ∅ H7	D6	H1	H2	H3	H4	L1	L2	L3	L4
80	7	M4	46	23	±0.2	±0.03	±0.1	±0.2	±0.2	±0.03
120	7	M5	68	34	55	20	203.3	116	76	40

Size	L5	L6	L7	L9	L10	T1	T2	T3	T4	T5
	±0.1	±0.1	±0.05				+0.1			
80	30	78	60	146	133	8.6	2.1	12	7	7.5
120	60	140	110	226.9	214.3	8.6	2.1	13	7.5	7.5

Data sheet

Dimensions

Download CAD data → www.festo.com

GK-C – Standard slide with lubrication adapter

Size 185

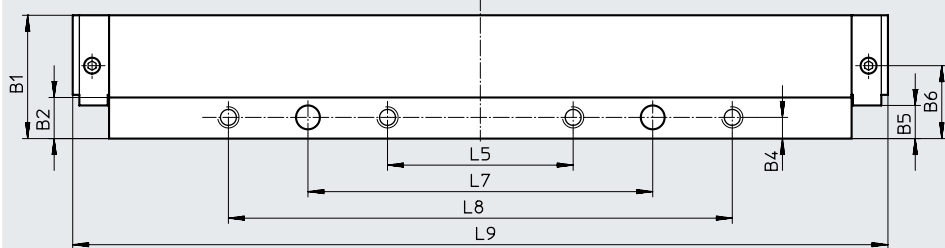
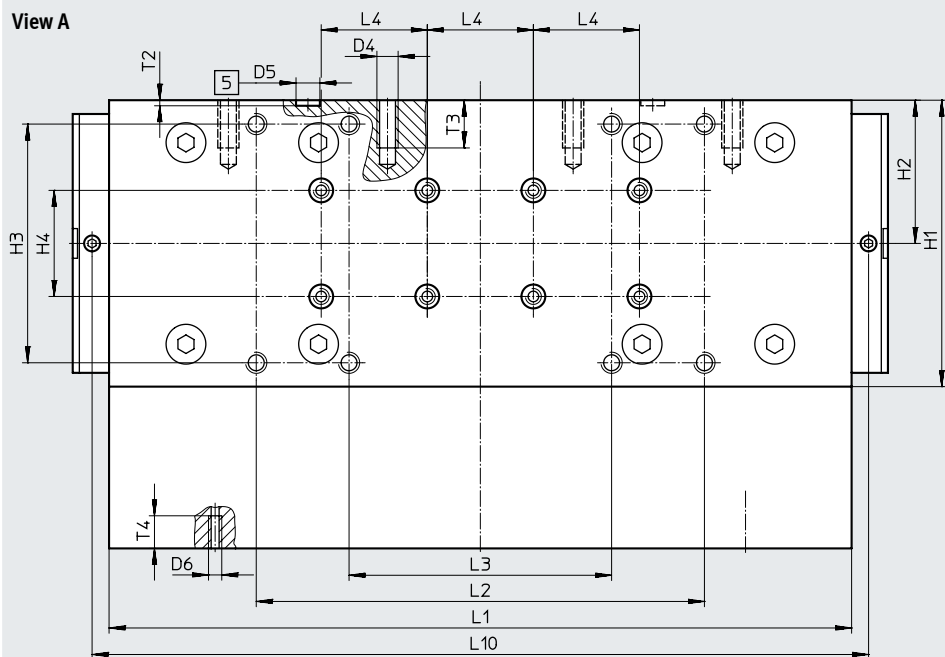
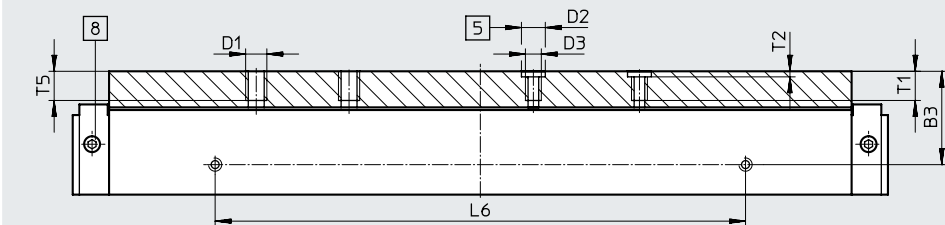

- [5] Drill hole for centring sleeve
- [8] Lubricating hole for lubrication adapter
M6 threaded connection, 6 mm deep

Size	B1	B2	B3	B4	B5	B6	D1	D2 ∅ H7	D3	D4
185	46.5	15.5	35.2	8	12.5 ±0.1	27.5	M8	9	M6	M8

Size	D5 ∅ H7	D6	H1	H2	H3	H4	L1	L2	L3	L4
185	9	M5	108	54	90 ±0.2	40 ±0.03	282.8 ±0.1	169 ±0.2	99 ±0.2	40 ±0.03

Size	L5	L6	L7	L8	L9	L10	T1	T2	T3	T4	T5
185	70 ±0.2	200 ±0.1	130 ±0.05	190 ±0.2	307.4	292.8	11	2.1 +0.1	18	12.3	12

Data sheet

Dimensions

Download CAD data → www.festo.com

GV-C – Extended slide with lubrication adapter

Size 80

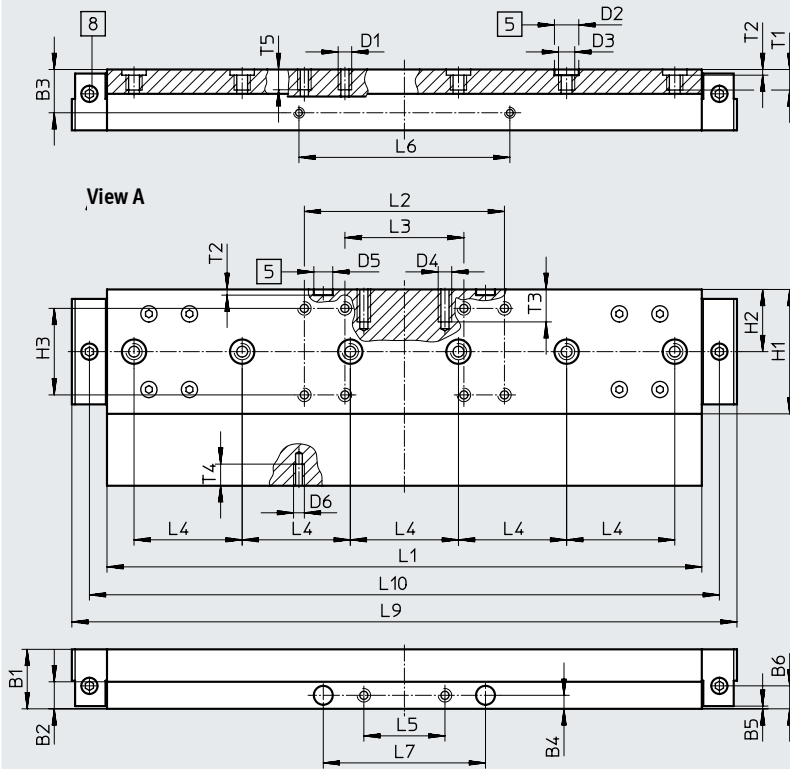

[5] Drill hole for centring sleeve

[8] Lubricating hole for lubrication adapter
M6 threaded connection, 6 mm deep

Size	B1	B2	B3	B4	B5	B6	D1	D2	D3	D4
80	22	10	16	5	±0.1 1	8.5	M5	∅ H7 9	M6	M5
Size	D5	D6	H1	H2	H3	L1	L2	L3	L4	L5
80	∅ H7 7	M4	46	23	±0.2 32	±0.1 220	±0.2 74	±0.2 44	±0.03 40	±0.1 30
Size	L6	L7	L9	L10	T1	T2	T3	T4	T5	
80	±0.1 78	±0.05 60	246	233	8.6	+0.1 2.1	12	7	7.5	

Data sheet

Dimensions

Download CAD data → www.festo.com

GV-C – Extended slide with lubrication adapter

Size 120

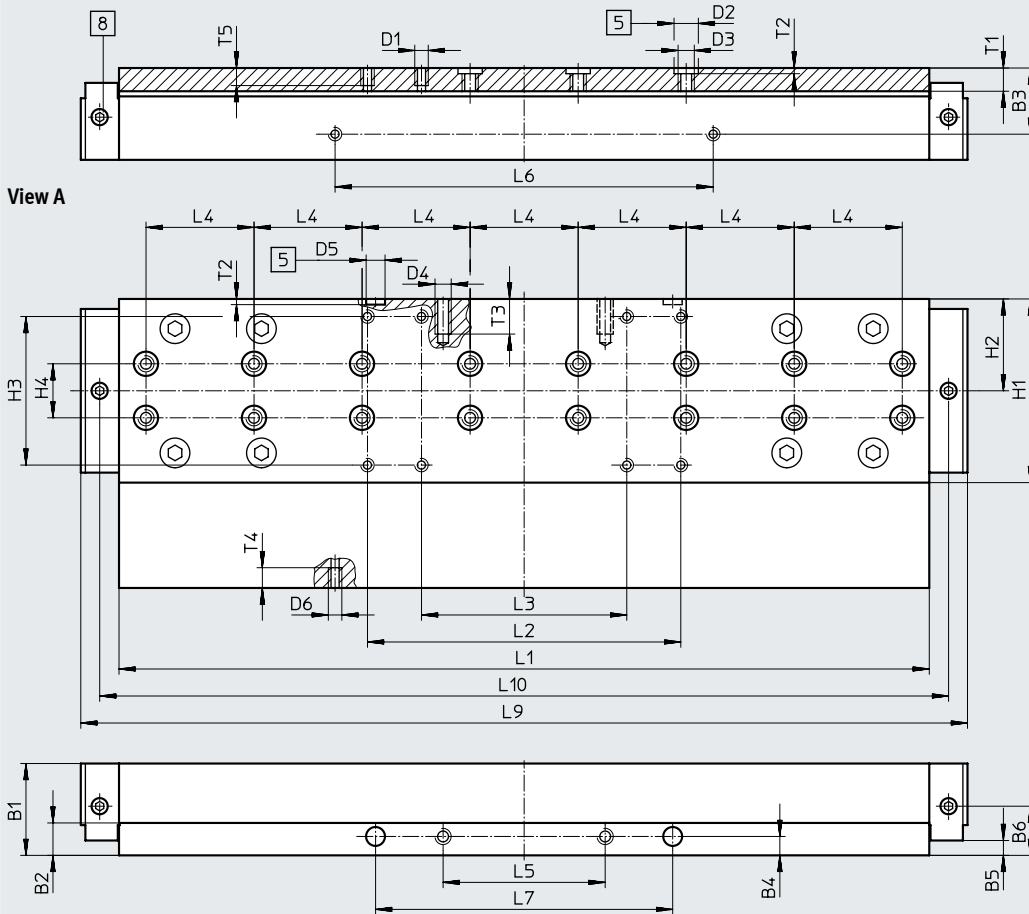

- [5] Drill hole for centring sleeve
- [8] Lubricating hole for lubrication adapter
M6 threaded connection, 6 mm deep

Size	B1	B2	B3	B4	B5	B6	D1	D2 ∅ H7	D3	D4
120	34	12	24.5	7	5.5 ±0.1	18.2	M5	9	M6	M6
Size	D5 ∅ H7	D6	H1	H2	H3	H4	L1	L2	L3	L4
120	7 ±0.2	M5	68	34	55 ±0.2	20 ±0.03	303.3 ±0.1	116 ±0.2	76 ±0.2	40 ±0.03
Size	L5	L6	L7	L9	L10	T1	T2	T3	T4	T5
120	60 ±0.1	140 ±0.1	110 ±0.05	326.9	314.3	8.6	2.1 ±0.1	13	7.5	7.5

Data sheet

Dimensions

Download CAD data → www.festo.com

GV-C – Extended slide with lubrication adapter

Size 185

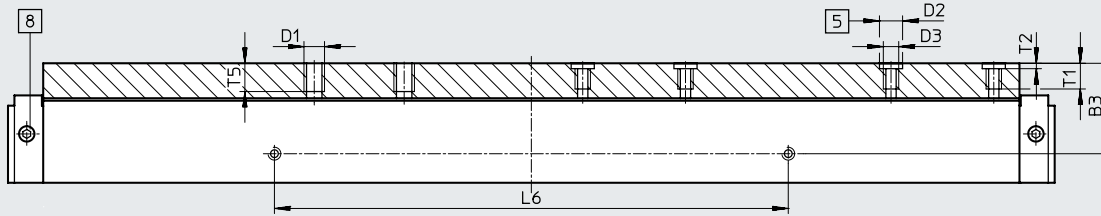

View A

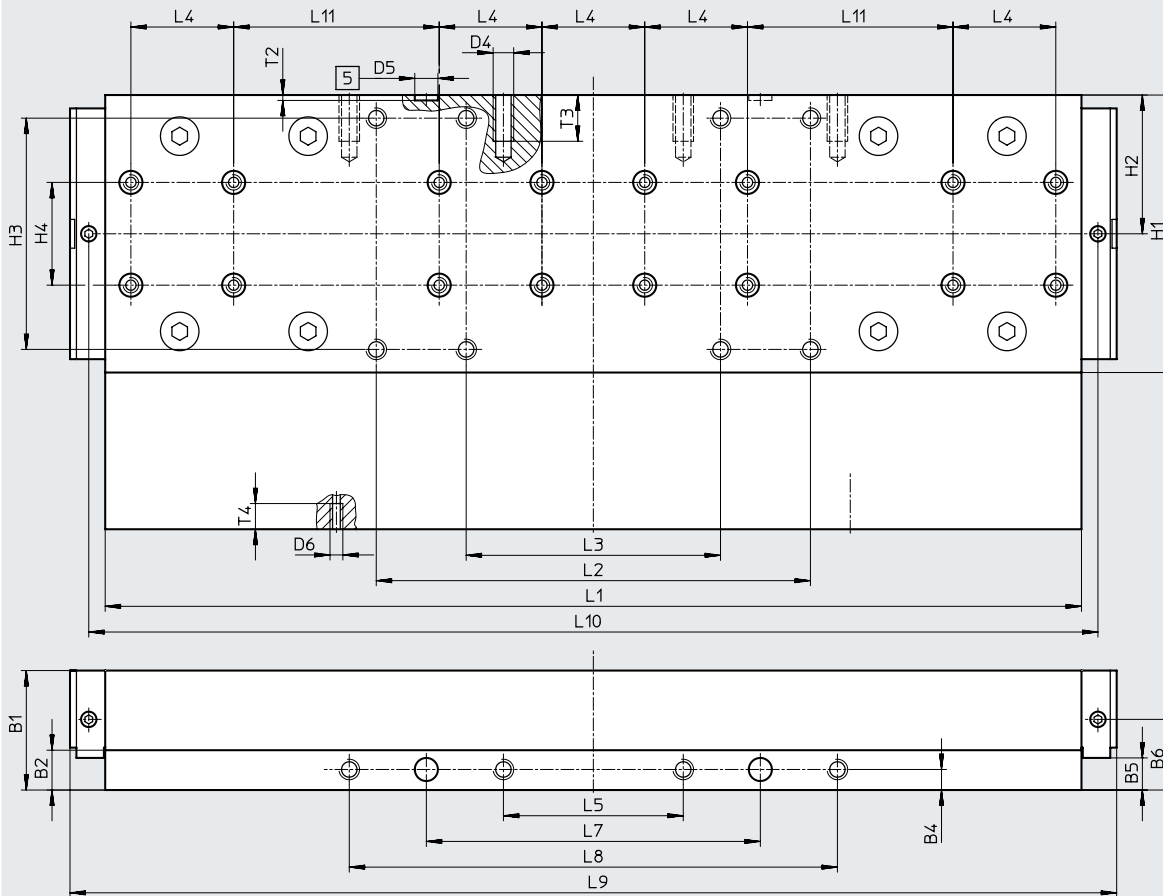

- [5] Drill hole for centring sleeve
- [8] Lubricating hole for lubrication adapter
- M6 threaded connection, 6 mm deep

Size	B1	B2	B3	B4	B5	B6	D1	D2 ∅ H7	D3	D4
185	46.5	15.5	35.2	8	±0.1 12.5	27.5	M8	9	M6	M8

Size	D5 ∅ H7	D6	H1	H2	H3	H4	L1	L2	L3	L4	L5
185	9	M5	108	54	±0.2 90	±0.03 40	±0.1 382.8	±0.2 169	±0.2 99	±0.03 40	±0.2 70

Size	L6	L7	L8	L9	L10	L11	T1	T2	T3	T4	T5
185	±0.1 200	±0.05 130	±0.2 190	407.4	392.8	±0.03 80	11	+0.1 2.1	18	10	12

Data sheet

Dimensions

Download CAD data → www.festo.com

1HL/1HR – With clamping unit

Size 80

1-channel, left

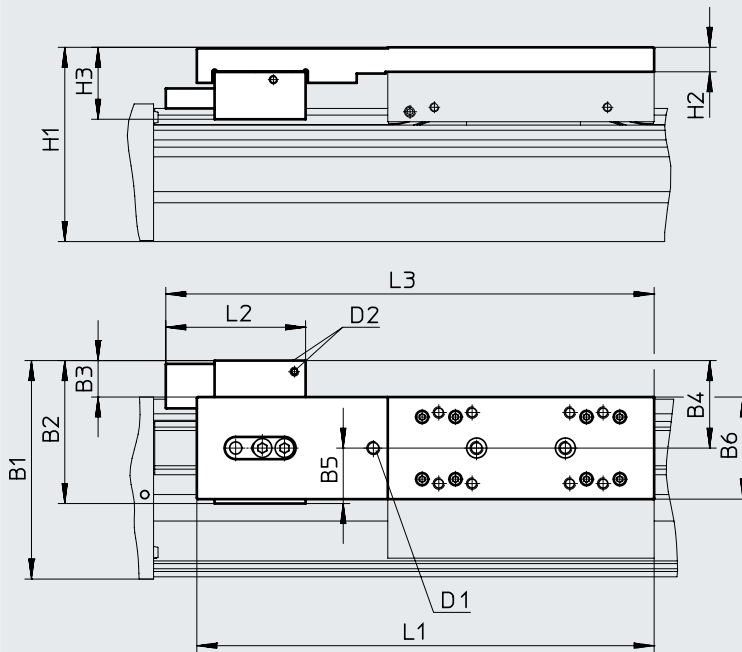

1-channel, right

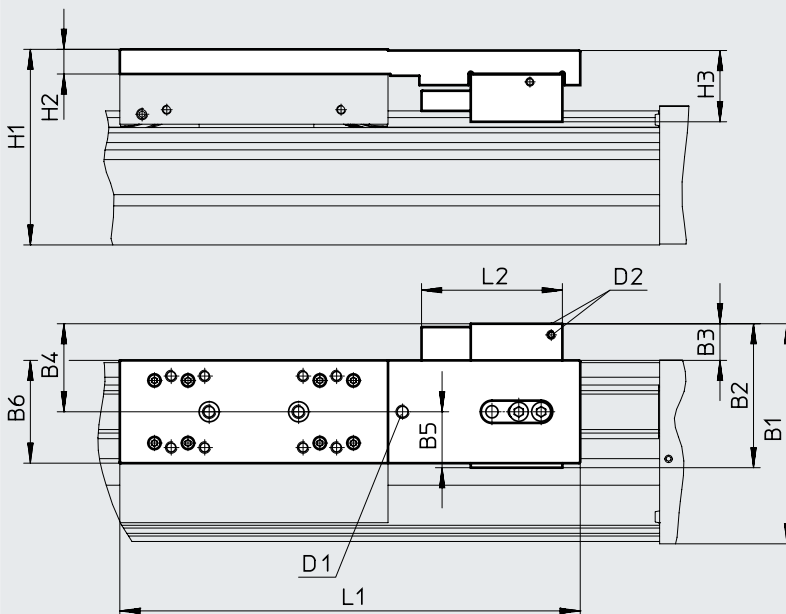

D1 Optional: threaded connection for lubrication adapter

D2 Compressed air supply ports

Working stroke reduction in combination with clamping unit → Page 21

Data sheet

Dimensions

Download CAD data → www.festo.com

2H – With clamping unit

Size 80

2-channel

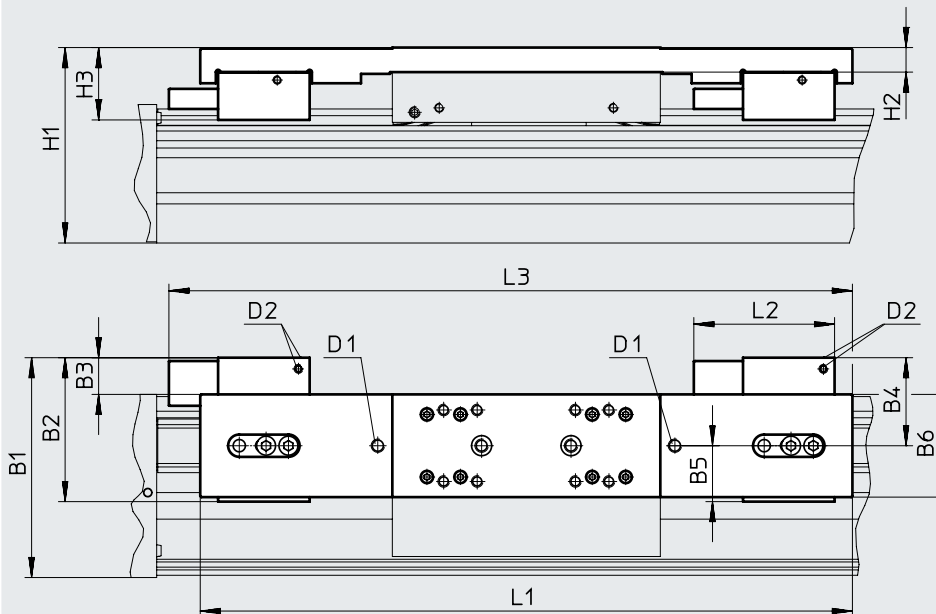

- D1 Optional: threaded connection for lubrication adapter
 D2 Compressed air supply ports

Working stroke reduction in combination with clamping unit → Page 21

Type	B1	B2	B3	B4	B5	B6	H1	H2	H3	D1	D2	L1	L2	L3
EGC-80-...-1HL-PN	98.4	64.4	17.4	39.4	25	46	87.5	11	32.4	M6	M5	206	63	220
EGC-80-...-1HR-PN														-
EGC-80-...-C-1HL-PN														220
EGC-80-...-C-1HR-PN														-
EGC-80-...-2H-PN												292		306
EGC-80-...-C-2H-PN														

Data sheet

Dimensions

Download CAD data → www.festo.com

1HL/1HR – With clamping unit

Size 120/185

1-channel, left

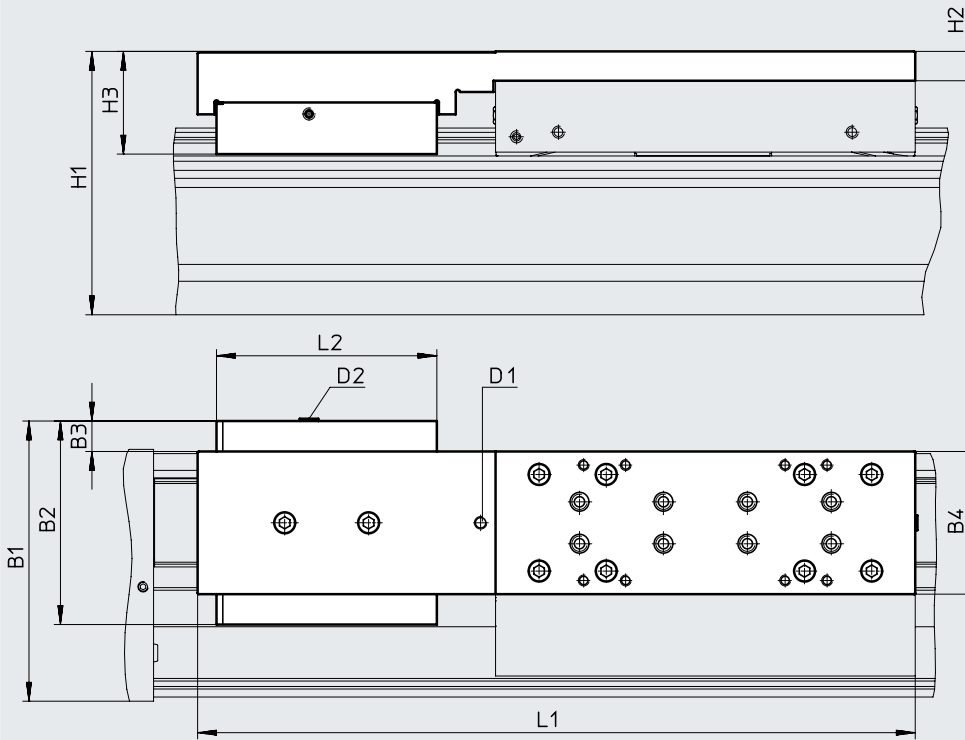

1-channel, right

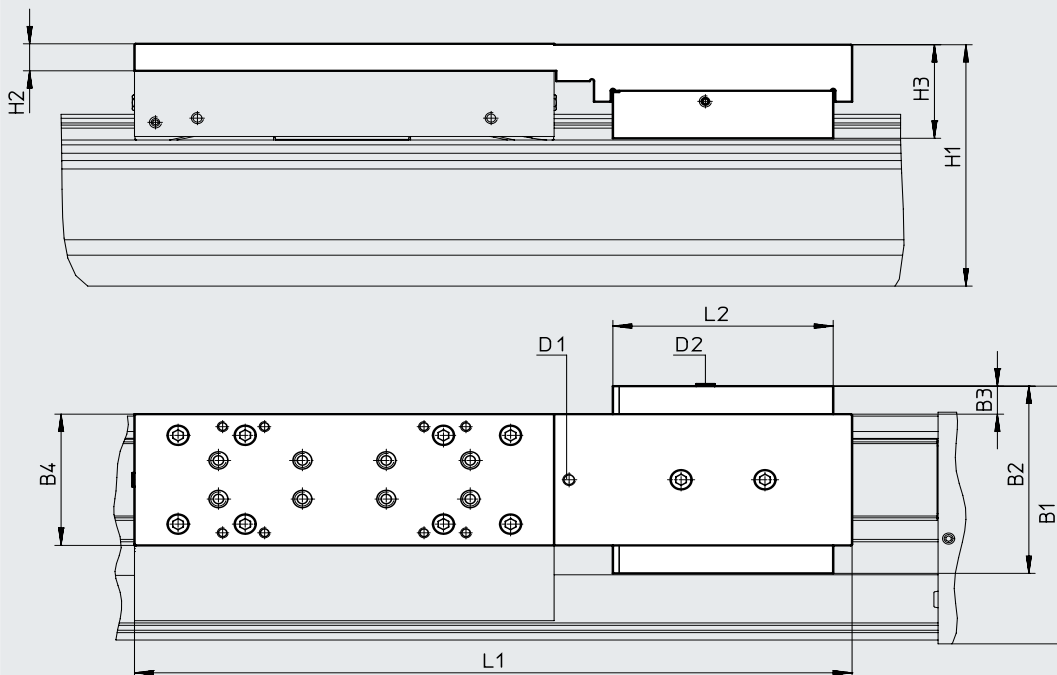

D1 Optional: threaded connection for lubrication adapter

D2 Compressed air supply port

Working stroke reduction in combination with clamping unit → Page 21

Data sheet

Dimensions

Download CAD data → www.festo.com

2H – With clamping unit

Size 120/185

2-channel

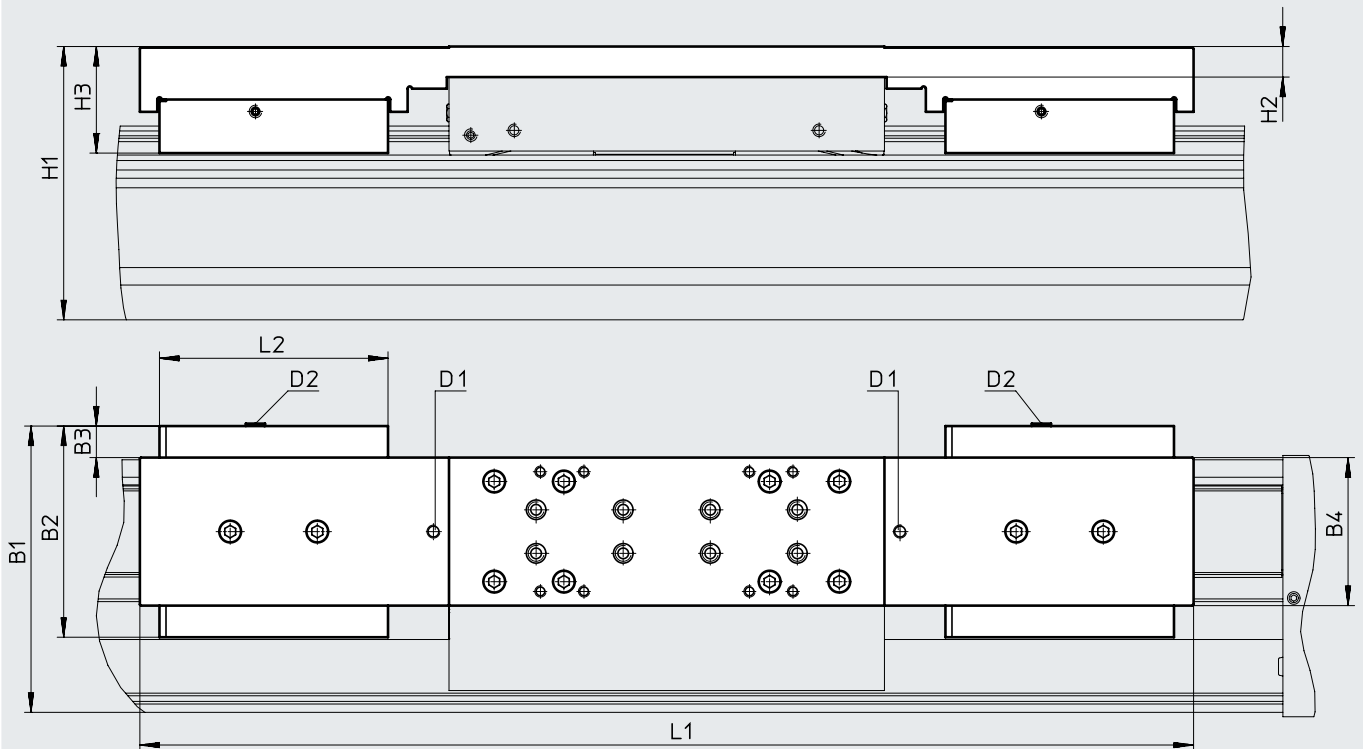

D1 Optional: threaded connection for lubrication adapter

D2 Compressed air supply ports

Working stroke reduction in combination with clamping unit → Page 21

Type	B1	B2	B3	B4	H1	H2	H3	D1	D2	L1	L2
Size 120											
EGC-120-...-1HL-PN	133.5	97	15.5	68	125.5	14	48.9	M6	M5	342	105
EGC-120-...-1HR-PN											
EGC-120-...-C-1HL-PN											
EGC-120-...-C-1HR-PN											
EGC-120-...-2H-PN										484	
EGC-120-...-C-2H-PN											
Size 185											
EGC-185-...-1HL-PN	196.5	131	12.5	108	189.5	17	64.1	M6	M5	432	109
EGC-185-...-1HR-PN											
EGC-185-...-C-1HL-PN											
EGC-185-...-C-1HR-PN											
EGC-185-...-2H-PN										584	
EGC-185-...-C-2H-PN											

Data sheet

Dimensions

Download CAD data → www.festo.com

M1/M2 – With incremental displacement encoder

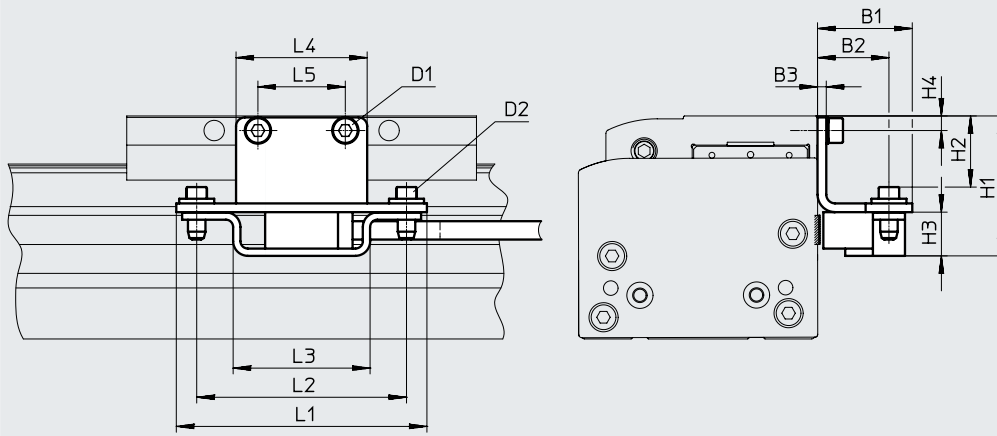

Encoder cable
(connection to the motor controller/safety system) → Page 61

Type	B1	B2	B3	H1	H2	H3	H4
EGC-70-...-M1	32.5	24.5	3	39	18.4	15	4.5
EGC-70-...-M2				39	18.4		4.5
EGC-80-...-M1				48	24.4		5
EGC-80-...-M2				48	24.4		5
EGC-120-...-M1				60	36.4		7
EGC-120-...-M2				60	36.4		7
EGC-185-...-M1				78.5	54.9		8
EGC-185-...-M2				78.5	54.9		8

Type	D1	D2	L1	L2	L3	L4	L5
EGC-70-...-M1	M5x8	M4x14	86	72	47	35	20
EGC-70-...-M2	M5x8					35	20
EGC-80-...-M1	M5x8					45	30
EGC-80-...-M2	M5x8					45	30
EGC-120-...-M1	M6x10					86	60
EGC-120-...-M2	M6x10					86	60
EGC-185-...-M1	M8x12					86	70
EGC-185-...-M2	M8x12					86	70

Data sheet

Ordering data

Key features:

- Stroke reserve: 0 mm
- Standard slide

Size	Stroke [mm]	Part no.	Type
70	300	★ 3012492	EGC-70-300-TB-KF-0H-GK
	400	★ 3012493	EGC-70-400-TB-KF-0H-GK
	500	★ 3012494	EGC-70-500-TB-KF-0H-GK
	600	★ 3012495	EGC-70-600-TB-KF-0H-GK
	800	★ 3012496	EGC-70-800-TB-KF-0H-GK
	1000	★ 3012497	EGC-70-1000-TB-KF-0H-GK
	1200	★ 3012498	EGC-70-1200-TB-KF-0H-GK
80	400	★ 575832	EGC-80-400-TB-KF-0H-GK
	500	★ 3013354	EGC-80-500-TB-KF-0H-GK
	600	★ 3013355	EGC-80-600-TB-KF-0H-GK
	800	★ 3013356	EGC-80-800-TB-KF-0H-GK
	1000	★ 3013357	EGC-80-1000-TB-KF-0H-GK
	1200	★ 3013359	EGC-80-1200-TB-KF-0H-GK
120	400	★ 3013364	EGC-120-400-TB-KF-0H-GK
	500	★ 3013365	EGC-120-500-TB-KF-0H-GK
	600	★ 3013366	EGC-120-600-TB-KF-0H-GK
	800	★ 3013367	EGC-120-800-TB-KF-0H-GK
	1000	★ 3013368	EGC-120-1000-TB-KF-0H-GK
	1200	★ 3013369	EGC-120-1200-TB-KF-0H-GK
	1500	★ 3013370	EGC-120-1500-TB-KF-0H-GK

Festo core product range



Generally ready for dispatch from the factory within 24 hours

Generally ready for dispatch from the factory within 5 days

Ordering data – Modular product system

Accessories

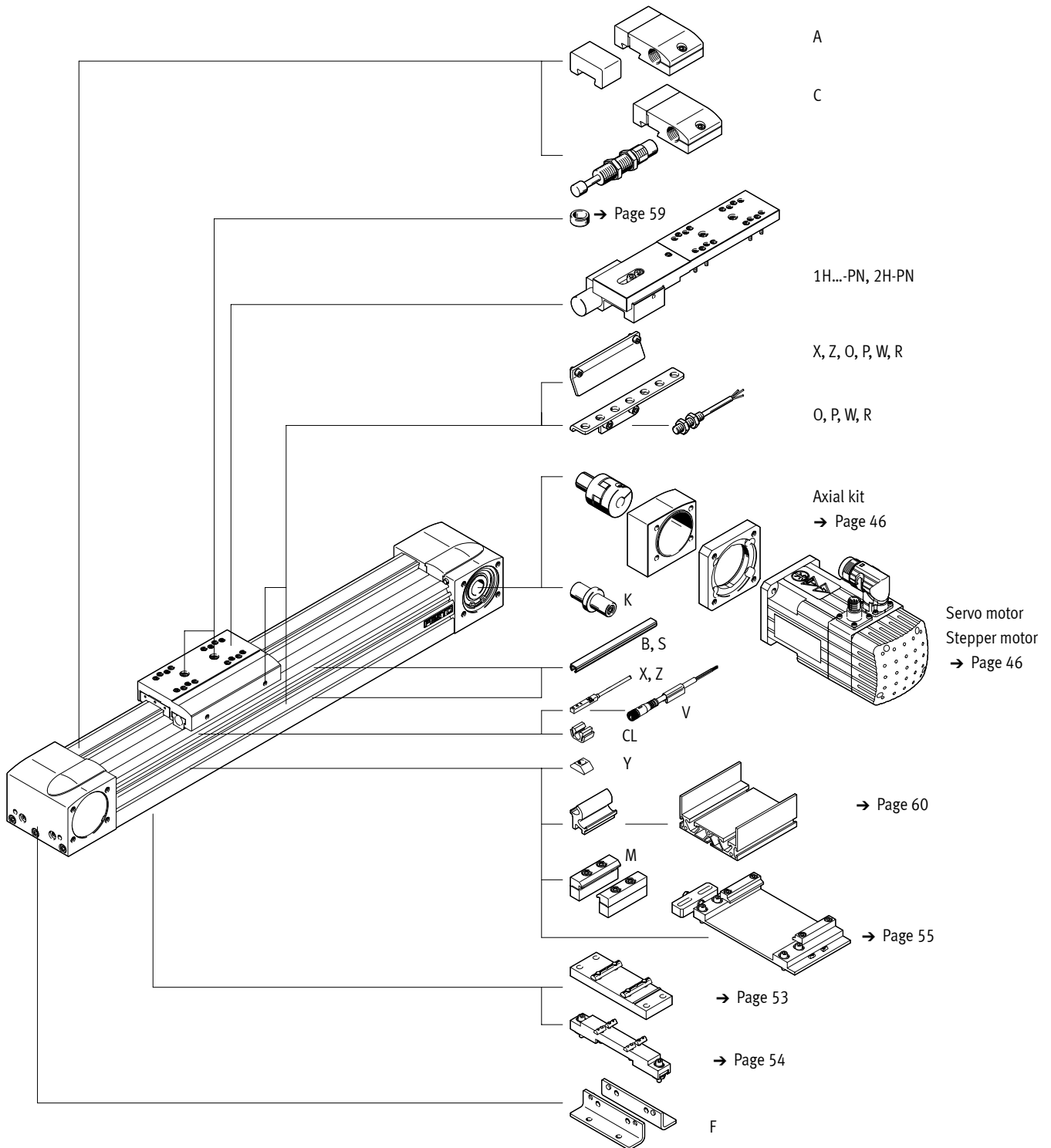

Ordering data – Modular product system

Ordering table									
Size	50	70	80	120	185	Condi- tions	Code	Enter code	
Module no.	556812	556813	556814	556815	556817				
Design	Linear axis							EGC	EGC
Size	50	70	80	120	185		★ -...	-...	
Stroke length [mm]	50 ... 1900	50 ... 5000	50 ... 8500	50 ... 8500 (50 ... 8400 with GV, GQ)	50 ... 8500 (50 ... 8400 with GV, GQ)	[1]	★ -...	-...	
Function	Toothed belt							★ -TB	-TB
Guide	Recirculating ball bearing guide							★ -KF	-KF
Stroke reserve [mm]	0 ... 999 (0 = no stroke reserve)					[1]	★ -...H		
Slide	Standard slide							★ -GK	
	-	Extended slide, protected			-		★ -GQ		
	-	Standard slide, protected			-		★ -GP		
	-	Extended slide			-		★ -GV		
Additional slide	Left	Additional slide, standard, left				[2]	★ -KL		
	Right	Additional slide, standard, right				[2]	★ -KR		
Lubrication function	Standard								
	-	-	Lubrication adapter				★ -C		
Displacement encoder, incremental	None								
	Resolution: 2.5 ìm							-M1	
	Resolution: 10 ìm							-M2	
Clamping unit	None								
	1-channel, left					[3]	-1HL		
	1-channel, right					[3]	-1HR		
	2-channel					[3]	-2H		
Actuation type	None								
	Pneumatic							-PN	
Material of toothed belt	Chloroprene rubber								
	Coated PU							-PU2	
EU certification	II 2G				-	[4]	-EX3		

- [1] -... The sum of the nominal stroke and 2x stroke reserve must not exceed the maximum stroke length
- [2] **KL, KR** If the protected slide variant (GQ, GP) is selected, the additional slide (KL, KR) is also protected
If the extended slide variant (GV, GQ) is selected, the additional slide (KL, KR) is not extended
If the slide with lubrication adapter (GK-C) is selected, the additional slide (KL, KR) is also supplied with lubrication adapter
Working stroke reduction in combination with additional slide (KL, KR) → Page 20
- [3] **1HL, 1HR, 2H** Not with slide GQ, GV as well as additional slide KL, KR
Only with PN
Working stroke reduction in combination with clamping unit (1HL, 1HR, 2H) → Page 21
- [4] **EX3** Not with M1, M2, 1HL, 1HR, 2H, PN, Z, ...X, ...Z, ...O, ...P, ...W, ...R, ...V, ...CL



Ordering data – Modular product system

		50	70	80	120	185	Conditions	Code	Enter code
Accessories		Accessories enclosed separately						ZUB-	ZUB-
Foot mounting		1						F	
Profile mounting		1 ... 50						...M	
Covering	Mounting slot	–	1 ... 50 (1 = 2 units, 500 mm long)				...B		
	Sensor slot	1 ... 50 (1 = 2 units, 500 mm long)				...S			
Slot nut for mounting slot		1 ... 99						...Y	
Proximity switch (SIES), inductive, slot type 8, PNP, incl. switch lug	N/O contact, 7.5 m cable	1 ... 6				...X			
	N/C contact, 7.5 m cable	1 ... 6				...Z			
Emergency buffer with retaining bracket		–	1 ... 2			[5]	...A		
Shock absorber with retaining bracket		1 ... 2					[6]	...C	
Proximity switch (SIEN), inductive, M8, PNP, incl. switch lug with sensor bracket	N/O contact, 2.5 m cable	–	1 ... 99				...O		
	N/C contact, 2.5 m cable	–	1 ... 99				...P		
lug with sensor bracket	N/O contact, M8 plug	–	1 ... 99				...W		
	N/C contact, M8 plug	–	1 ... 99				...R		
Connecting cable 2.5 m M8, 3-wire		1 ... 99						...V	
Drive shaft		1 ... 4					[7]	...K	
Cable clip		10, 20, 30, 40, 50, 60, 70, 80, 90						...CL	
Operating instructions		Express waiver – no operating instructions to be included as already available (operating instructions in PDF format are available free of charge on our website at www.festo.com)						-DN	

[5] ... A Emergency buffer with retaining bracket A cannot be combined with slide GP, GQ, GK-C, GV-C, shock absorber with retaining bracket C and clamping unit 1H...PN, 2H-PN

[6] ... C Shock absorber with retaining bracket C cannot be combined with slide GP, GQ, GK-C, GV-C, emergency buffer with retaining bracket A and clamping unit 1H...PN, 2H-PN

[7] ... K No drive shaft is required for the axis/motor combinations → from page 46 onwards.

Note

The code X, Z includes a switch lug in the scope of delivery.

The code O, P, W, R includes one switch lug and max. two sensor brackets in the scope of delivery.

Festo core product range



Generally ready for dispatch from the factory within 24 hours

Generally ready for dispatch from the factory within 5 days

Accessories

-  - Note

Depending on the combination of motor and drive, it may not be possible to reach the maximum feed force of the drive.

Permissible axis/motor combinations with axial kit

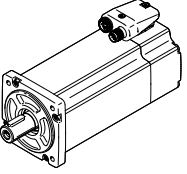
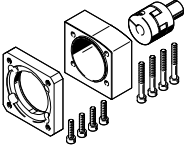
Motor/gear unit ¹⁾	Axial kit	
Type	Part no.	Type
		
EGC-50		
With servo motor		
EMMS-AS-55-...	557975	EAMM-A-L27-55A
With servo motor and gear unit		
EMME-AS-40-... EMGA-40-P-G...-EAS-40	★ 557974	EAMM-A-L27-40G
EMMS-AS-40-... EMGA-40-P-G...-SAS-40	★ 557974	EAMM-A-L27-40G
With servo motor and right-angle gear unit		
EMME-AS-40-... EMGA-40-A-G...-40P	★ 557974	EAMM-A-L27-40G
With stepper motor		
EMMS-ST-57-...	★ 560678	EAMM-A-L27-57A
With stepper motor and gear unit		
EMMS-ST-42-... EMGA-40-P-G...-SST-42	★ 557974	EAMM-A-L27-40G
With integrated drive		
EMCA-EC-67-...	1454261	EAMM-A-L27-67A
With integrated drive and gear unit		
EMCA-EC-67-... EMGC-40	★ 557974	EAMM-A-L27-40G
EGC-70		
With servo motor		
EMMS-AS-55-...	3683331	EAMM-A-L38-55A
EMMT-AS-60-...	★ 2037246	EAMM-A-L38-60P
EMME-AS-60-...	★ 2037246	EAMM-A-L38-60P
EMMS-AS-70-...	557979	EAMM-A-L38-70A
With servo motor and gear unit		
EMMS-AS-55-... EMGA-60-P-G...-SAS-55	★ 557978	EAMM-A-L38-60G
EMMT-AS-60-... EMGA-60-P-G...-EAS-60	1456610	EAMM-A-L38-60H
EMME-AS-60-... EMGA-60-P-G...-EAS-60	1456610	EAMM-A-L38-60H
EMMS-AS-70-... EMGA-60-P-G...-SAS-70	★ 557978	EAMM-A-L38-60G
With servo motor and right-angle gear unit		
EMMT-AS-60-... EMGA-60-A-G...-60P	1456610	EAMM-A-L38-60H
EMME-AS-60-... EMGA-60-A-G...-60P	1456610	EAMM-A-L38-60H

1) The input torque must not exceed the max. permissible transferable torque of the axial kit.

Festo core product range



Generally ready for dispatch from the factory within 24 hours

Generally ready for dispatch from the factory within 5 days

Accessories

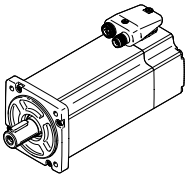
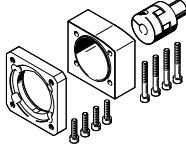
Permissible axis/motor combinations with axial kit		
Motor/gear unit ¹⁾	Axial kit	
		
Type	Part no.	Type
EGC-70		
With stepper motor		
EMMS-ST-57-...	★ 560679	EAMM-A-L38-57A
EMMS-ST-87-...	★ 560680	EAMM-A-L38-87A
With stepper motor and gear unit		
EMMS-ST-57-...	★ 557978	EAMM-A-L38-60G
EMGA-60-P-G...-SST-57		
With integrated drive and gear unit		
EMCA-EC-67-...	1456610	EAMM-A-L38-60H
EMGC-60-...		
EGC-80		
With servo motor		
EMMS-AS-70-...	557982	EAMM-A-L48-70A
EMME-AS-80-...	★ 2042616	EAMM-A-L48-80P
EMME-AS-100-...	557984	EAMM-A-L48-100A
EMMS-AS-100-...	557984	EAMM-A-L48-100A
With servo motor and gear unit		
EMMS-AS-55-...	★ 557983	EAMM-A-L48-60G
EMGA-60-P-G...-SAS-55		
EMMT-AS-60-...	1456611	EAMM-A-L48-60H
EMGA-60-P-G...-EAS-60		
EMME-AS-60-...	1456611	EAMM-A-L48-60H
EMGA-60-P-G...-EAS-60		
EMMS-AS-70-...	★ 557983	EAMM-A-L48-60G
EMGA-60-P-G...-SAS-70		
With servo motor and right-angle gear unit		
EMMT-AS-60-...	1456611	EAMM-A-L48-60H
EMGA-60-A-G...-60P		
EMME-AS-60-...	1456611	EAMM-A-L48-60H
EMGA-60-A-G...-60P		
With stepper motor		
EMMS-ST-87-...	★ 560683	EAMM-A-L48-87A
With stepper motor and gear unit		
EMMS-ST-57-...	★ 557983	EAMM-A-L48-60G
EMGA-60-P-G...-SST-57		
With integrated drive and gear unit		
EMCA-EC-67-...	1456611	EAMM-A-L48-60H
EMGC-60-...		

1) The input torque must not exceed the max. permissible transferable torque of the axial kit.

Festo core product range



Generally ready for dispatch from the factory within 24 hours
Generally ready for dispatch from the factory within 5 days

Accessories

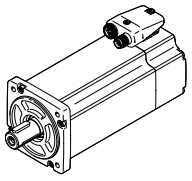
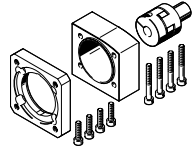
Permissible axis/motor combinations with axial kit		
Motor/gear unit ¹⁾	Axial kit	
		
Type	Part no.	Type
EGC-120		
With servo motor		
EMME-AS-100-...	★ 557988	EAMM-A-L62-100A
EMMS-AS-100-...	★ 557988	EAMM-A-L62-100A
EMMS-AS-140-...	557990	EAMM-A-L62-140A
With servo motor and gear unit		
EMMS-AS-70-... EMGA-80-P-G...-SAS-70	★ 557989	EAMM-A-L62-80G
EMME-AS-80-... EMGA-80-P-G...-EAS-80	★ 557989	EAMM-A-L62-80G
EMME-AS-100-... EMGA-80-P-G...-SAS-100	★ 557989	EAMM-A-L62-80G
EMMS-AS-100-... EMGA-80-P-G...-SAS-100	★ 557989	EAMM-A-L62-80G
With servo motor and right-angle gear unit		
EMME-AS-80-... EMGA-80-A-G...-80P	★ 557989	EAMM-A-L62-80G
EMME-AS-100-... EMGA-80-A-G...-100A	★ 557989	EAMM-A-L62-80G
With stepper motor and gear unit		
EMMS-ST-87-... EMGA-80-P-G...-SST-87	★ 557989	EAMM-A-L62-80G
EGC-185		
With servo motor		
EMMS-AS-140-...	3657226	EAMM-A-L95-140A-G2
EMMS-AS-190-...	3659562	EAMM-A-L95-190A-G2
With servo motor and gear unit		
EMMS-AS-70-... EMGA-80-P-G...-SAS-70	3660191	EAMM-A-L95-80G-G2
EMME-AS-80-... EMGA-80-P-G...-EAS-80	3660191	EAMM-A-L95-80G-G2
EMME-AS-100-... EMGA-80-P-G...-SAS-100	3660191	EAMM-A-L95-80G-G2
EMMS-AS-100-... EMGA-80-P-G...-SAS-100	3660191	EAMM-A-L95-80G-G2
EMME-AS-100-... EMGA-120-P-G...-SAS-100	★ 3659941	EAMM-A-L95-120G-G2
EMMS-AS-100-... EMGA-120-P-G...-SAS-100	★ 3659941	EAMM-A-L95-120G-G2
EMMS-AS-140-... EMGA-120-P-G...-SAS-140	★ 3659941	EAMM-A-L95-120G-G2
With servo motor and right-angle gear unit		
EMME-AS-80-... EMGA-80-A-G...-80P	3660191	EAMM-A-L95-80G-G2
EMME-AS-100-... EMGA-80-A-G...-100A	3660191	EAMM-A-L95-80G-G2

1) The input torque must not exceed the max. permissible transferable torque of the axial kit.



Festo core product range



Generally ready for dispatch from the factory within 24 hours

Generally ready for dispatch from the factory within 5 days

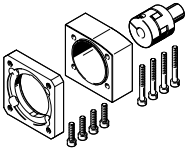
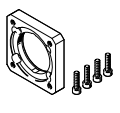
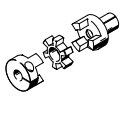
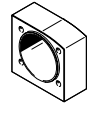
Accessories

Individual components of the axial kit				
Axial kit	Comprising:			
	Motor flange	Coupling	Coupling housing	Screw kit
				
Part no. Type	Part no. Type	Part no. Type	Part no. Type	Part no. Type
EGC-50				
★ 557974 EAMM-A-L27-40G	558015 EAMF-A-L27-40G	557998 EAMD-19-15-10-8X10	–	–
557975 EAMM-A-L27-55A	558016 EAMF-A-L27-55A	557999 EAMD-19-15-9-8X10	–	–
★ 560678 EAMM-A-L27-57A	560690 EAMF-A-L27-57A	561292 EAMD-16-15-6.35-8X10	–	–
1454261 EAMM-A-L27-67A	1460087 EAMF-A-L27-67A	557999 EAMD-19-15-9-8X10	–	–
EGC-70				
3683331 EAMM-A-L38-55A	558176 EAMF-A-38A-55A	3717923 EAMD-25-22-9-10X12	558011 EAMK-A-L38-38A	567484 EAHM-L2-M5-30
★ 560679 EAMM-A-L38-57A	560692 EAMF-A-38A-57A	561293 EAMD-25-22-6.35-10X12	558011 EAMK-A-L38-38A	567484 EAHM-L2-M5-30
★ 557978 EAMM-A-L38-60G	558017 EAMF-A-38A-60G/H	558000 EAMD-25-22-11-10X12	558011 EAMK-A-L38-38A	567485 EAHM-L2-M5-35
1456610 EAMM-A-L38-60H	558017 EAMF-A-38A-60G/H	1453861 EAMD-28-22-14-10X12	558011 EAMK-A-L38-38A	567485 EAHM-L2-M5-35
★ 2037246 EAMM-A-L38-60P	1987412 EAMF-A-38A-60P	1453861 EAMD-28-22-14-10X12	558011 EAMK-A-L38-38A	567485 EAHM-L2-M5-35
557979 EAMM-A-L38-70A	558018 EAMF-A-38A-70A	558000 EAMD-25-22-11-10X12	558011 EAMK-A-L38-38A	567484 EAHM-L2-M5-30
★ 560680 EAMM-A-L38-87A	560693 EAMF-A-38A-87A	558000 EAMD-25-22-11-10X12	558011 EAMK-A-L38-38A	567485 EAHM-L2-M5-35
EGC-80				
★ 557983 EAMM-A-L48-60G	558019 EAMF-A-48A-60G/H	558001 EAMD-32-32-11-16X20	558012 EAMK-A-L48-48A	567487 EAHM-L2-M5-45
1456611 EAMM-A-L48-60H	558019 EAMF-A-48A-60G/H	1377840 EAMD-32-32-14-16X20	558012 EAMK-A-L48-48A	567487 EAHM-L2-M5-45
557982 EAMM-A-L48-70A	558025 EAMF-A-48A-70A	558001 EAMD-32-32-11-16X20	558012 EAMK-A-L48-48A	567486 EAHM-L2-M5-40
★ 2042616 EAMM-A-L48-80P	2043427 EAMF-A-48A-80P	558002 EAMD-42-40-19-16X25	558012 EAMK-A-L48-48A	567489 EAHM-L2-M5-55
★ 560683 EAMM-A-L48-87A	560695 EAMF-A-48A-87A	558001 EAMD-32-32-11-16X20	558012 EAMK-A-L48-48A	567487 EAHM-L2-M5-45
557984 EAMM-A-L48-100A	558020 EAMF-A-48A-100A	558002 EAMD-42-40-19-16X25	558012 EAMK-A-L48-48A	567489 EAHM-L2-M5-55



Festo core product range



★ Generally ready for dispatch from the factory within 24 hours

★ Generally ready for dispatch from the factory within 5 days

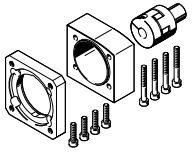
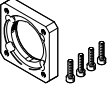
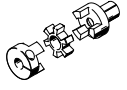
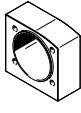
Accessories

Individual components of the axial kit				
Axial kit	Comprising:			
	Motor flange 	Coupling 	Coupling housing 	Screw kit 
Part no. Type	Part no. Type	Part no. Type	Part no. Type	Part no. Type
EGC-120				
★ 557989 EAMM-A-L62-80G	558021 EAMF-A-62A-80G	558004 EAMD-56-46-20-23X27	558013 EAMK-A-L62-62A	567492 EAHM-L2-M6-65-L
★ 557988 EAMM-A-L62-100A	558026 EAMF-A-62A-100A	558003 EAMD-56-46-19-23X27	558013 EAMK-A-L62-62A	567491 EAHM-L2-M6-65
557990 EAMM-A-L62-140A	558022 EAMF-A-62A-140A	558005 EAMD-56-46-24-23X27	558013 EAMK-A-L62-62A	567493 EAHM-L2-M6-70
EGC-185				
3660191 EAMM-A-L95-80G-G2	3305700 EAMF-A-95B-80G	3717812 EAMD-67-51-20-32X32-U	3712650 EAMK-A-L95-95A/B-G2	–
★ 3659941 EAMM-A-L95-120G-G2	3659724 EAMF-A-95A-120G-G2	558006 EAMD-67-51-25-32X32-U	3712650 EAMK-A-L95-95A/B-G2	567496 EAHM-L2-M8-70
3657226 EAMM-A-L95-140A-G2	558023 EAMF-A-95A-140A	558008 EAMD-67-51-24-32X32-U	3712650 EAMK-A-L95-95A/B-G2	567497 EAHM-L2-M8-80
3659562 EAMM-A-L95-190A-G2	1378473 EAMF-A-95A-190A	1379269 EAMD-67-51-32-32X32-U	3712650 EAMK-A-L95-95A/B-G2	567497 EAHM-L2-M8-80

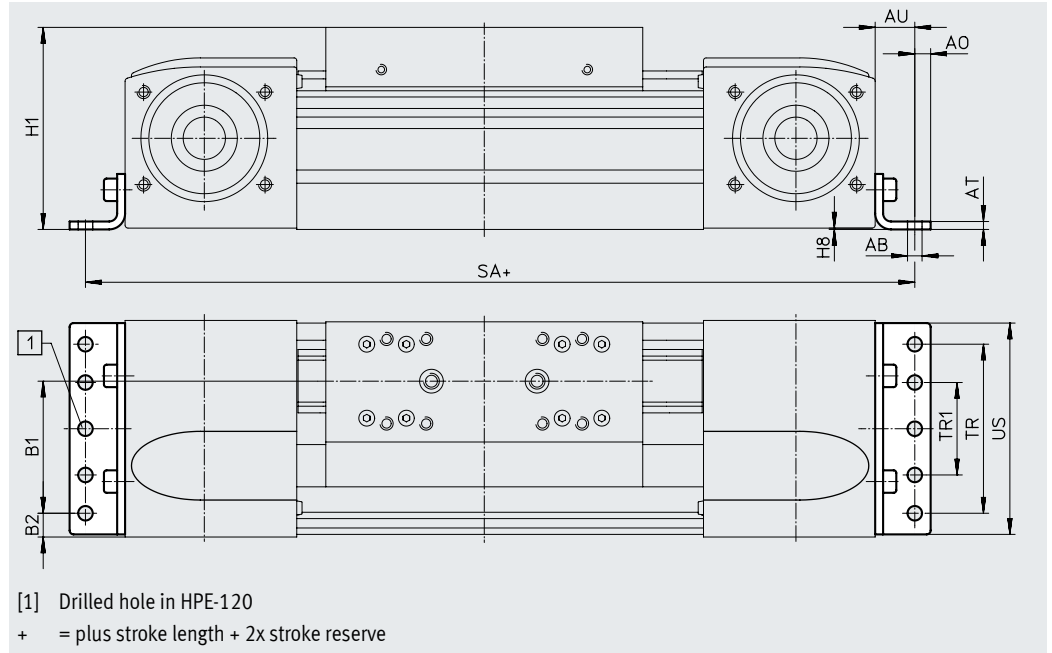

Accessories

Foot mounting HPE
(order code F)Material:
Galvanised steel
RoHS-compliant

Dimensions and ordering data

For size	AB ∅	A0	AT	AU	B1	B2	H1	H8
50	4.5	4.5	2	10.5	21.5	14	42.5	0.5
70	5.5	6	3	13	37	14.5	64	0.5
80	5.5	6	3	15	38	21	76.5	0.5
120	9	8	6	22	65	20	111.5	0.6
185	9	12	8	25	118	13	172.5	0.5

For size	SA		TR	TR1	US	Weight [g]	Part no.	Type ¹⁾
	EGC...-GK	EGC...-GV						
50	176	–	20	–	46	44	558320	HPE-50
70	272	372	40	–	67	115	558321	HPE-70
80	316	416	40	–	80	150	558322	HPE-80
120	490	590	80	–	116	578	558323	HPE-120
185	662	762	160	80	182	1438	558325	HPE-185

1) Suitable for ATEX

Accessories

Profile mounting MUE
(order code M)

Material:
Anodised aluminium
RoHS-compliant

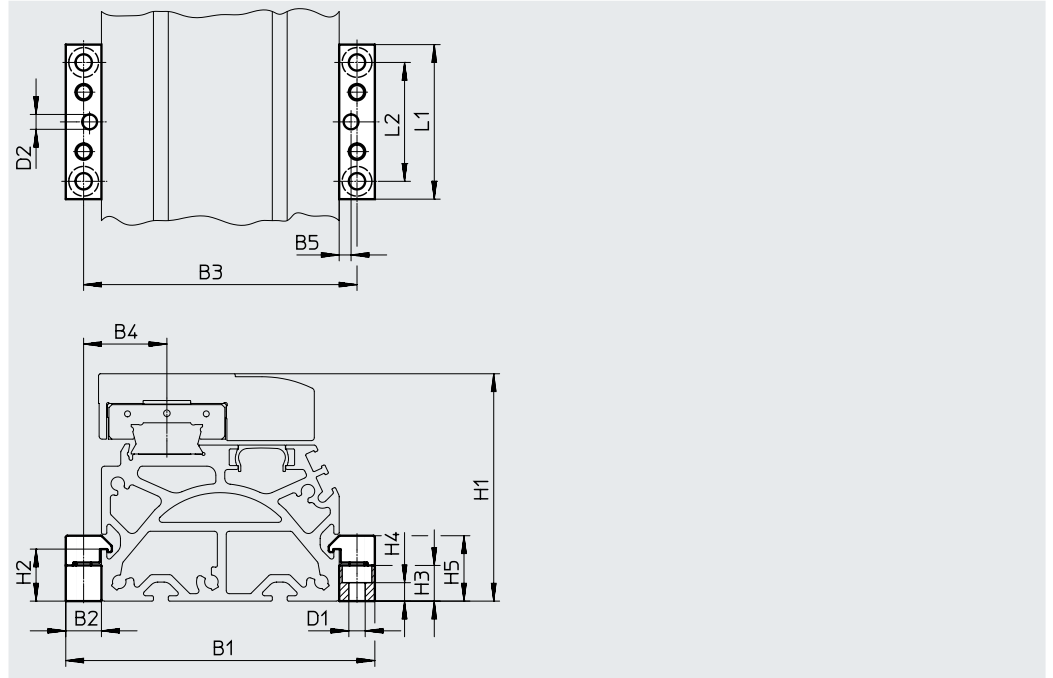

Dimensions and ordering data

For size	B1	B2	B3	B4	B5	D1 ∅	D2 ∅ H7	H1	H2
50	62	8	54	15.5	4	3.4	5	42.5	6
70	91	12	79	22.5	4	5.5	5	64	17.5
80	104	12	92	28	4	5.5	5	76.5	17.5
120	154	19	135	42.5	4	9	5	111.5	16
185	220	19	201	62.5	4	9	5	172.5	16

For size	H3	H4	H5	L1	L2	Weight [g]	Part no.	Type ¹⁾
50	5.5	2.3	11	40	20	20	☆ 558042	MUE-50
70	12	6.2	22	52	40	80	☆ 558043	MUE-7 0/80
80	12	6.2	22	52	40	80	☆ 558043	MUE-7 0/80
120	14	5.5	29.5	90	40	290	☆ 558044	MUE-12 0/185
185	14	5.5	29.5	90	40	290	☆ 558044	MUE-12 0/185

1) Suitable for ATEX

Accessories

Central support EAHF

Material:
Anodised aluminium
RoHS-compliant

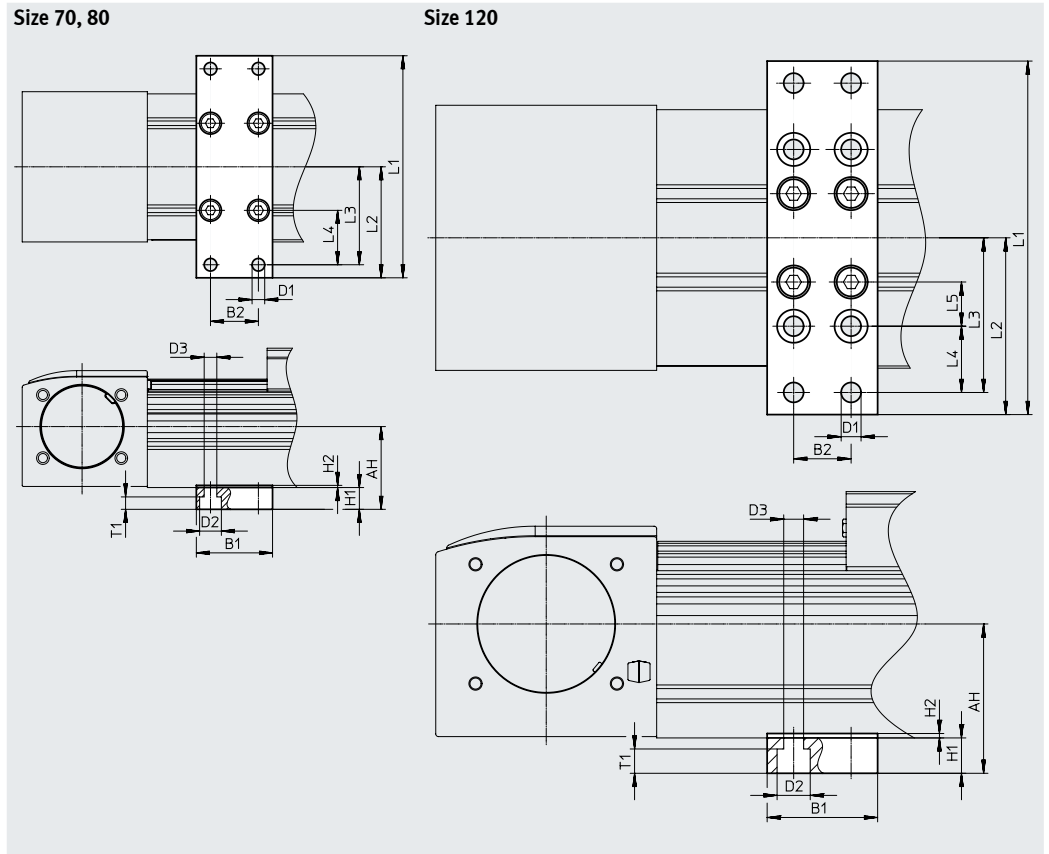

Dimensions and ordering data

For size	AH	B1	B2	D1 ∅	D2 ∅	D3 ∅	H1	L1
70	38	35	22	5.8	10	5.8	10	102
80	44.5		30					112
120	67.6	50	26	9	15	9	16	160

For size	L2	L3	L4	L5	T1	Weight [g]	Part no.	Type
70	51	45	25	-	5.7	113	2349256	EAHF-L5-70-P ¹⁾
80	56	50	30			123	3535188	EAHF-L5-80-P ¹⁾
120	80	70	30	20	11	384	2410274	EAHF-L5-120-P

1) Suitable for ATEX

Accessories

Adjusting kit EADC-E15

Material:
 EADC-E15-5 0/80/120: wrought aluminium alloy
 EADC-E15-185: steel
 RoHS-compliant

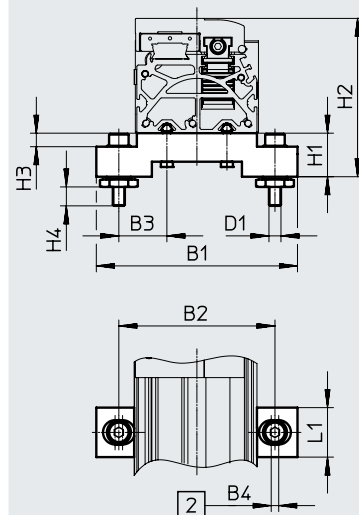
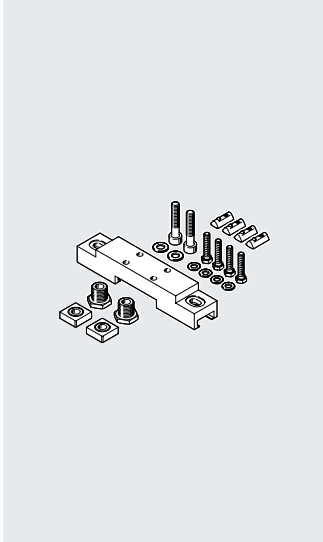

[2] Width of elongate hole

Dimensions and ordering data

For size	B1	B2	B3	B4	D1	H1
50	84	62	21	5	M5	20
70	134	104	32	5	M8	29
80	134	104	32	5	M8	29
120	170	140	50	5	M8	29
185	236	209	64.5	5	M8	29

For size	H2	H3	H4	L1	Weight [g]	Part no.	Type
50	62.5	5	9.6	25	126	8047565	EADC-E15-50-E7
70	93	9	12.6	33	386	8047566	EADC-E15-80-E7
80	105.5	9	12.6	33	386	8047566	EADC-E15-80-E7
120	140.5	9	12.6	33	388	8047567	EADC-E15-120-E7
185	201.5	9	12.6	33	569	8047568	EADC-E15-185-E7

Accessories

Adjusting kit EADC-E16

Material:
Wrought aluminium alloy
RoHS-compliant

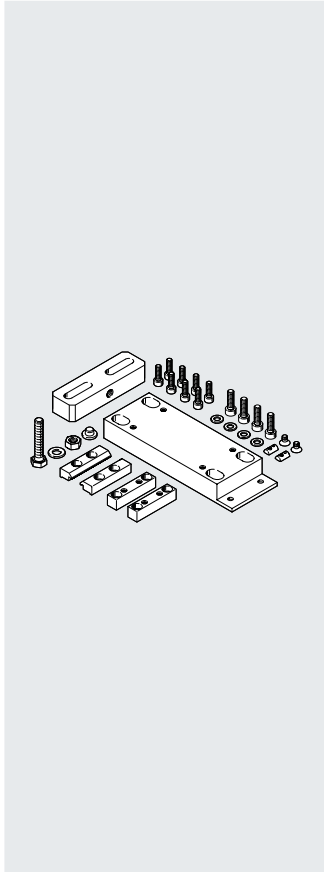

Size 50, 80

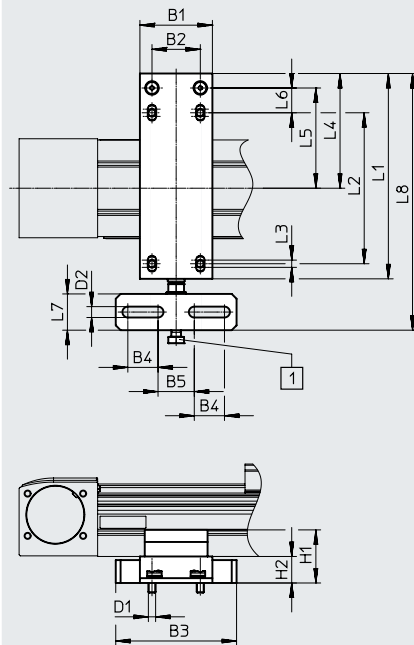

Size 120, 185

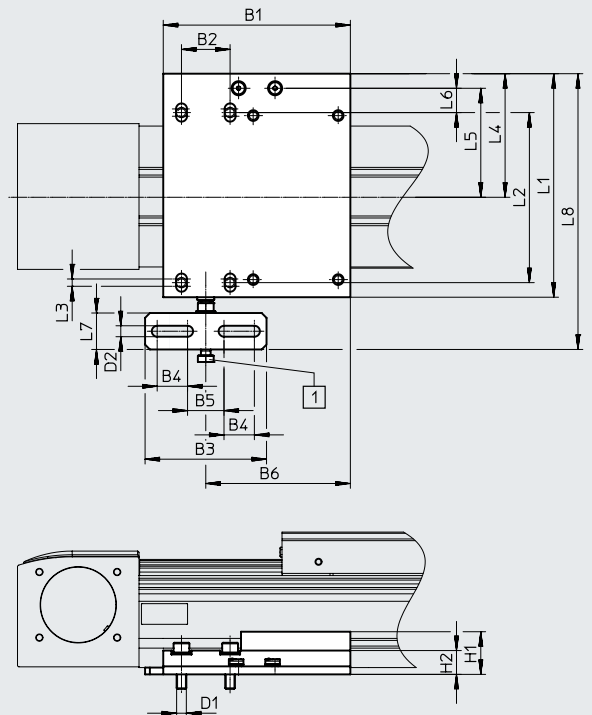

[1] M8 screw

Dimensions and ordering data

For size	B1	B2	B3	B4	B5	B6	D1	D2	H1	H2	L1	L2
50	60	40	100	25	30	-	M4	9	25.1	19.6	130	80
80	60	40	100	25	30	-	M6	9	44	22	170	125
120	154	40	100	25	30	119	M8	9	35.1	19.6	184	140
185	150	40	100	25	30	119	M8	9	35.1	19.6	272	220

For size	L3	L4	L5	L6	L7	L8	Weight [g]	Part no.	Type
50	6	78	66	26	30	173	498	8047576	EADC-E16-50-E7
80	6	95	83	20.5	30	212.5	828	8047577	EADC-E16-80-E7
120	6	101.7	89.7	20	30	227	1134	8047578	EADC-E16-120-E7
185	6	150	138	28	30	315	1457	8047579	EADC-E16-185-E7

Accessories

Shock absorber retainer KYE

Emergency buffer NPE → Page 59

Shock absorber YSRW → Page 59
(order code A or C)

Material:
Anodised aluminium
RoHS-compliant

Cannot be used in combination with
the variants GP and GQ or GK-C and
GV-C and 1H...-PN, 2H-PN.

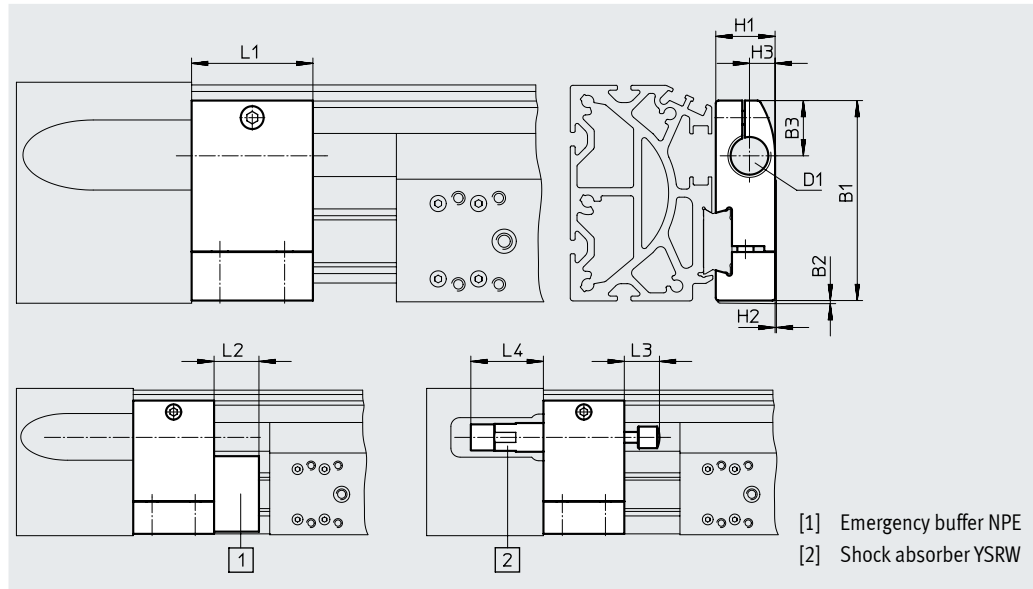

Dimensions and ordering data

For size	B1	B2	B3	D1	H1	H2	H3	L1	L2	L3	L4 min.	Weight [g]	Part no.	Type ¹⁾
50	38	1	13.5	M8x1	12	0.4	5	20	12	8	20	20	557583	KYE-50
70	57.5	1	16.5	M12x1	18.2	0.5	7.5	30	15	14	32	75	557584	KYE-70
80	74.2	1	20.5	M16x1	22	0.5	9.5	45	25	20	41	170	557585	KYE-80
120	108.5	1	26	M22x1.5	31	1	14	60	40	26	48.5	680	557586	KYE-120
185	168	1	37	M26x1.5	42	4	18	75	60	34	58.5	1075	557587	KYE-185

1) Suitable for ATEX

Switch lug SF-EGC-1

For sensing via proximity switch

SIES-8M

(order code X or Z)

Material:
Galvanised steel
RoHS-compliant

- With size 50, max. 3 proximity switches can be supported when sensing both end positions.

For additional proximity switches, a stroke reserve of 25 mm is required.

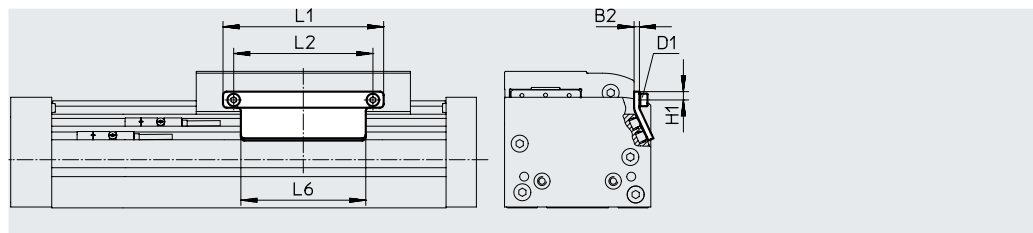

Dimensions and ordering data

For size	B2	D1	H1	L1	L2	L6	Weight [g]	Part no.	Type ¹⁾
50	2	M3	3.5	45	22	45	20	★ 558046	SF-EGC-1-50
70	3	M4	4.65	70	56	50	50	★ 558047	SF-EGC-1-70
80	3	M4	4.65	90	78	70	63	★ 558048	SF-EGC-1-80
120	3	M5	8	170	140	170	147	★ 558049	SF-EGC-1-120
185	3	M5	10	230	200	230	246	★ 558051	SF-EGC-1-185

1) Suitable for ATEX

Accessories

Switch lug SF-EGC-2

For sensing via proximity switch
SIEN-M8B (order code O, P, W or R) or
SIES-8M (order code X or Z)

Switch lug SF-EGC-2

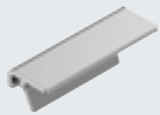
**Material:**

Galvanised steel
RoHS-compliant

Sensor bracket HWS-EGC

For proximity switch SIEN-M8B
(order code O, P, W or R)

Material:

Galvanised steel
RoHS-compliant

Sensor bracket HWS-EGC

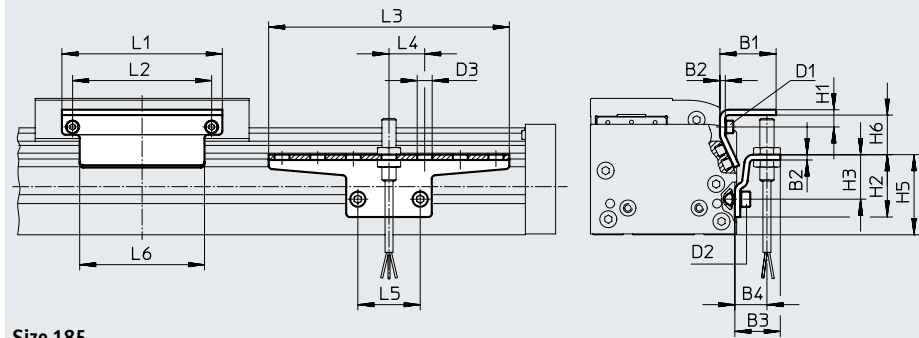
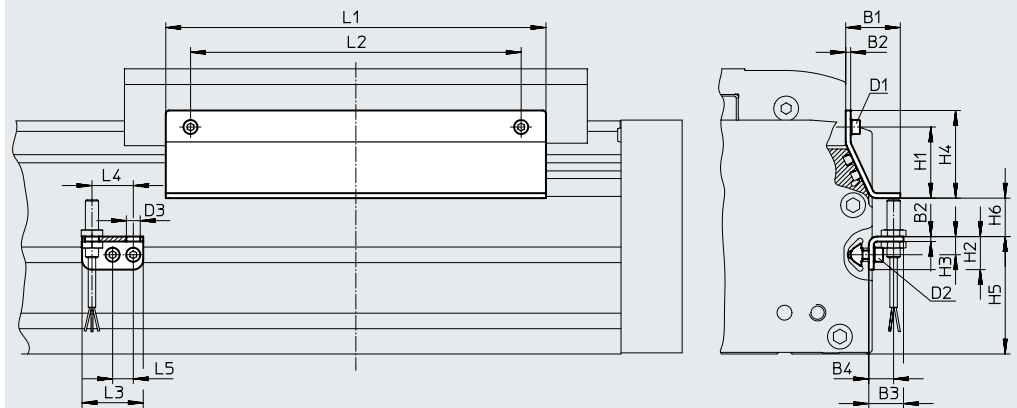
**Size 70 ... 120****Size 185****Dimensions and ordering data**

For size	B1	B2	B3	B4	D1	D2	D3	H1	H2
70	31.5	3	25.5	18	M4	M5	8.4	9.5	35
80	31.5	3	25.5	18	M4	M5	8.4	9.5	35
120	32	3	25.5	18	M5	M5	8.4	13.2	65
185	33	3	25.5	15	M5	M5	8.4	43	20

For size	H3	H4	H5	H6 max.	L1	L2	L3	L4	L5	L6
70	25	–	45	13.5	70	56	135	20	35	50
80	25	–	45	23.5	90	78	135	20	35	70
120	55	–	75	24	170	140	215	20	35	170
185	11	53	71	25.5	230	200	37	25	12.5	230

For size	Weight [g]	Part no.	Type
Switch lug			
70	100	558052	SF-EGC-2-70
80	130	558053	SF-EGC-2-80
120	277	558054	SF-EGC-2-120
185	390	558056	SF-EGC-2-185

For size	Weight [g]	Part no.	Type
Sensor bracket			
70	110	558057	HWS-EGC-M5
80	110	558057	HWS-EGC-M5
120	217	570365	HWS-EGC-M8-B
185	58	560517	HWS-EGC-M8:KURZ

Accessories

Drive shaft EAMB
Alternative interface
(order code K)

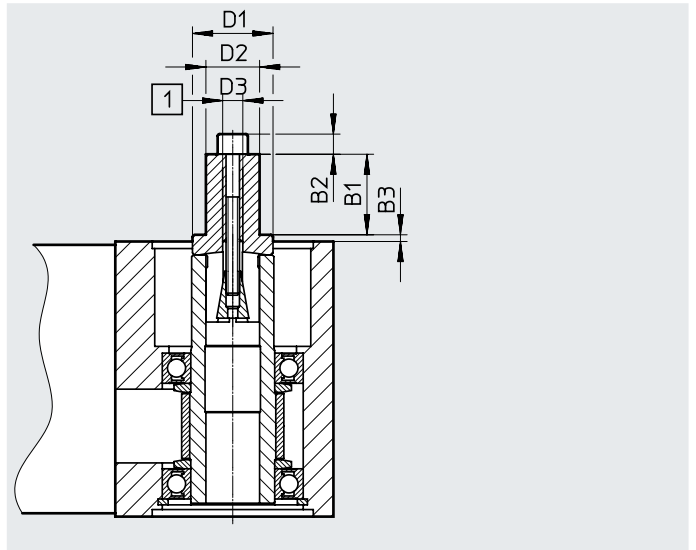





Dimensions and ordering data

For size	B1	B2	B3	D1 ∅	D2 ∅	D3	Weight [g]	Part no.	Type ¹⁾
50	12	3	1.1	16	8	M4	20	558034	EAMB-16-7-8X15-8X10
70	12	4	1.85	18	8	M5	29	558035	EAMB-18-9-8X16-10X12
80	21	–	2	24	15	M6	70	558036	EAMB-24-6-15X21-16X20
120	26	–	2	34	25	M10	201	558037	EAMB-34-6-25X26-23X27
185	30	–	3	44	35	M10	463	558038	EAMB-44-7-35X30-32X32

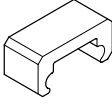
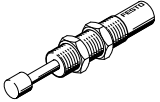
1) Suitable for ATEX

Accessories

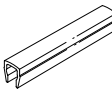
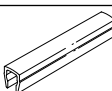
Ordering data						
	For size	Description	Order code	Part no.	Type ²⁾	PE ¹⁾
Emergency buffer NPE						
	50	For use in combination with shock absorber retainer KYE	A	564897	NPE-50	1
	70			562581	NPE-70	
	80			562582	NPE-80	
	120			562583	NPE-120	
	185			562584	NPE-185	
Shock absorber YSRW			Data sheets → Internet: ysrw			
	50	For use in combination with shock absorber retainer KYE	C	191192	YSRW-5-8	1
	70			191194	YSRW-8-14	
	80			191196	YSRW-12-20	
	120			191197	YSRW-16-26	
	185			191198	YSRW-20-34	
Slot nut NST						
	50	For mounting slot	Y	558045	NST-3-M3	1
		70, 80	For mounting slot	Y	150914	NST-5-M5
120, 185		For mounting slot	Y	8047843	NST-5-M5-10	10
				8047878	NST-5-M5-50	50
	120, 185	For mounting slot	Y	150915	NST-8-M6	1
				8047868	NST-8-M6-10	10
				8047869	NST-8-M6-50	50
Centring pin/sleeve ZBS/ZBH						
	50, 70	For slide	-	150928	ZBS-5	10
	80, 120, 185			150927	ZBH-9	
Slot cover ABP						
	70, 80	For mounting slot	B	151681	ABP-5	2
	120, 185	Every 0.5 m		151682	ABP-8	
Slot cover ABP-S						
	50 ... 185	For sensor slot Every 0.5 m	S	563360	ABP-5-S1	2

1) Packaging unit

2) Suitable for ATEX

Ordering data						
	For size	Description	Order code	Part no.	Type	PE ¹⁾
Clip SMBK						
	50 ... 185	For sensor slot, for attaching the proximity switch cables	CL	534254	SMBK-8	10

1) Packaging unit

Accessories

Mounting options between axis and support profile

Depending on the adapter kit, the spacing between the axis and the support profile is:
x = 20 mm or 50 mm

The support profile must be mounted using at least 2 adapter kits. For longer strokes, an adapter kit must be used every 500 mm.

Example

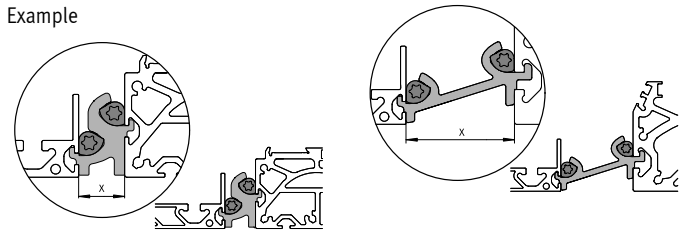

Ordering data		For size	Description	Part no.	Type	PE ¹⁾
Adapter kit DHAM						
	70, 80	• For mounting the support profile on the axis • Spacing between axis and profile is 20 mm		562241	DHAM-ME-N1-CL	1
	120, 185			562242	DHAM-ME-N2-CL	
	70, 80	• For mounting the support profile on the axis • Spacing between axis and profile is 50 mm		574560	DHAM-ME-N1-50-CL	
	120, 185			574561	DHAM-ME-N2-50-CL	
Support profile HMIA						
	70 ... 185	• For guiding an energy chain		539379	HMIA-E07-	1





1) Packaging unit



Ordering data – Proximity switches for T-slot, inductive

Data sheets → Internet: sies

	Type of mounting	Electrical connection	Switching output	Cable length [m]	Order code	Part no.	Type
N/O contact							
	Insertable in the slot from above, flush with the cylinder profile	Cable, 3-wire	PNP	7.5	X	551386	SIES-8M-PS-24V-K-7.5-OE
		Plug M8x1, 3-pin		0.3	–	551387	SIES-8M-PS-24V-K-0.3-M8D
		Cable, 3-wire	NPN	7.5	–	551396	SIES-8M-NS-24V-K-7.5-OE
		Plug M8x1, 3-pin		0.3	–	551397	SIES-8M-NS-24V-K-0.3-M8D
N/C contact							
	Insertable in the slot from above, flush with the cylinder profile	Cable, 3-wire	PNP	7.5	Z	551391	SIES-8M-PO-24V-K-7.5-OE
		Plug M8x1, 3-pin		0.3	–	551392	SIES-8M-PO-24V-K-0.3-M8D
		Cable, 3-wire	NPN	7.5	–	551401	SIES-8M-NO-24V-K-7.5-OE
		Plug M8x1, 3-pin		0.3	–	551402	SIES-8M-NO-24V-K-0.3-M8D

Accessories

Ordering data – Proximity switches M8 (round design), inductive							Data sheets → Internet: sien
	Electrical connection	LED	Switching output	Cable length [m]	Order code	Part no.	Type
N/O contact							
	Cable, 3-wire	■	PNP	2.5	0	★ 150386	SIEN-M8B-PS-K-L
			NPN	2.5	–	★ 150384	SIEN-M8B-NS-K-L
	Plug M8x1, 3-pin	■	PNP	–	W	★ 150387	SIEN-M8B-PS-S-L
			NPN	–	–	★ 150385	SIEN-M8B-NS-S-L
N/C contact							
	Cable, 3-wire	■	PNP	2.5	P	150390	SIEN-M8B-PO-K-L
			NPN	2.5	–	150388	SIEN-M8B-NO-K-L
	Plug M8x1, 3-pin	■	PNP	–	R	150391	SIEN-M8B-PO-S-L
			NPN	–	–	150389	SIEN-M8B-NO-S-L

Ordering data – Connecting cables					Data sheets → Internet: nebu
	Electrical connection, left	Electrical connection, right	Cable length [m]	Part no.	Type
	Straight socket, M8x1, 3-pin	Cable, open end, 3-wire	2.5	159420	SIM-M8-3GD-2.5-PU
			2.5	★ 541333	NEBU-M8G3-K-2.5-LE3
			5.0	★ 541334	NEBU-M8G3-K-5-LE3
	Angled socket, M8x1, 3-pin	Cable, open end, 3-wire	2.5	★ 541338	NEBU-M8W3-K-2.5-LE3
			5.0	★ 541341	NEBU-M8W3-K-5-LE3

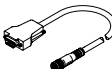
Ordering data – Encoder cables for displacement encoder, EGC-...-M1/-M2					Data sheets → Internet: nebm
	Electrical connection, left	Electrical connection, right	Cable length [m]	Part no.	Type
	Displacement encoder EGC-...-M1/-M2	Motor controller CMMP-AS-...	5.0	1599105	NEBM-M12G8-E-5-S1G9-V3
			10	1599106	NEBM-M12G8-E-10-S1G9-V3
			15	1599107	NEBM-M12G8-E-15-S1G9-V3
			χ ¹⁾	1599108	NEBM-M12G8-E-...-S1G9-V3

1) Max. cable length 25 m.

Festo core product range



Generally ready for dispatch from the factory within 24 hours

Generally ready for dispatch from the factory within 5 days