

- 1
- 2
- 3
- 4
- 5
- 6
- 7
- 8
- 9
- 10
- 11
- 12
- 13
- 14
- 15
- 16
- 17
- 18

BODY AND NO-SLIP COATING

NBR rubber.
Hardness 60 Shore A ±5.

SPRING AND PLATE

Zinc-plated steel.

SPRING CAPS

Aluminium.

FEATURES AND APPLICATIONS

AVM spring mounts comprise a body and a non-slip coating fixed to the lower part with a zinc-plated screw, and a spring on which two caps with pass-through holes at the ends are fixed.

They are generally used for vibration isolation in compression.

Vibrations can cause:

- malfunctioning and reduction of the machine lifespan and/or of the adjacent ones;
- damage to health;
- noise.

They are particularly suitable for use with HVAC, compressors, refrigeration units, centrifuges, crushers, vibrating screens and generators.

See High performance vibration dampers - Features and guidelines for the choice (on page -).



SPECIAL EXECUTIONS ON REQUEST

- Vibration dampers with one spring, with pins or threaded holes with a baseplate.
- Vibration dampers with spring, with two plates.
- Vibration dampers with spring, with one or two plates and pins for transport.

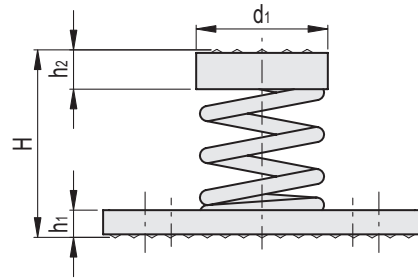
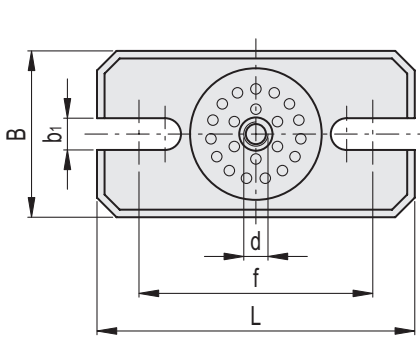

Code	Description	B	L	H	d	d1	b1	h1	h2	f±5*	Min load [N]	Max load [N]	Min deflection [mm]	Max. deflection [mm]	⚖️
480121	AVM-50-13	55	105	62	M8	43.5	10.5	9	13	75	50	130	5	15	360
480123	AVM-50-25	55	105	62	M8	43.5	10.5	9	13	75	80	250	5	15	370
480125	AVM-50-35	55	105	62	M8	43.5	10.5	9	13	75	120	350	5	15	380
480127	AVM-50-50	55	105	62	M8	43.5	10.5	9	13	75	180	500	5	15	400
480129	AVM-50-80	55	105	62	M8	43.5	10.5	9	13	75	270	800	5	15	380
480131	AVM-50-115	55	105	62	M8	43.5	10.5	9	13	75	400	1150	5	15	430
480133	AVM-50-135	55	105	62	M8	43.5	10.5	9	13	75	450	1350	5	15	420
480135	AVM-50-155	55	105	62	M8	43.5	10.5	9	13	75	600	1550	5	13	450
480137	AVM-50-200	55	105	62	M8	48	10.5	9	18	75	850	2000	5	12	470
480141	AVM-80-15	55	105	92	M8	43.5	10.5	9	13	75	80	150	10	20	360
480143	AVM-80-35	55	105	92	M8	43.5	10.5	9	13	75	150	350	10	20	370
480145	AVM-80-55	55	105	92	M8	43.5	10.5	9	13	75	270	550	10	20	380
480147	AVM-80-80	55	105	92	M8	43.5	10.5	9	13	75	400	800	10	20	400
480149	AVM-80-100	55	105	92	M8	43.5	10.5	9	13	75	500	1000	10	20	490
480151	AVM-80-140	55	105	92	M8	43.5	10.5	9	13	75	700	1400	10	20	450
480153	AVM-80-175	55	105	92	M8	43.5	10.5	9	13	75	900	1750	10	20	490
480155	AVM-80-215	55	105	92	M8	48	10.5	9	18	75	1050	2150	10	20	530
480157	AVM-80-350	55	105	92	M8	48	10.5	9	18	75	1750	3500	10	20	610
480159	AVM-80-510	55	105	92	M8	48	10.5	9	18	75	3400	5100	10	15	650

* Fixing holes centre distance.

The min. load is the value below which the vibration damper is not able to isolate the vibrations as it would be too rigid.

The max load is the value beyond which some type of failure may occur that compromises the functionality of the vibration damper.

The min.deflection is the crushing of the vibration-damping support corresponding to the min. load.

The max.deflection is the crushing of the vibration-damping support corresponding to the max. load.