



Model Number

BT65-F31K2-RG-EN

Activator for F31K2 series

Features

- High-visibility valve position display
- Protection against contamination and damage
- Two actuation targets in two levels with 5° setting grid
- Suitable for right and left rotating drives

Technical Data

General specifications

Ring diameter	≤ 65 mm
Spring ring height	≤ 6 mm

Nominal ratings

Valve status indication	red = CLOSED green = OPEN
-------------------------	------------------------------

Ambient conditions

Ambient temperature	-40 ... 75 °C (-40 ... 167 °F)
---------------------	--------------------------------

Mechanical specifications

Shaft diameter	≤ 49 mm
Shaft height	20 mm and 30 mm
Mounting hole pattern	30 x 80 mm

Material

Housing	PC
Actuator	PA
Spacer disk	PA (1 unit, 10 mm strong)
Mounting screw	Stainless steel 1.4401 / AISI 316
Activation target	Stainless steel 1.4305 / AISI 303 (integrated)

General information

Scope of delivery	1 screw M6 x 30 1 screw M6 x 40 1 Activator for F31K2 series 1 Distance disc 1 Protective cover Fixing screws
-------------------	--

Compliance with standards and directives

Standard conformity	
Standards	VDI / VDE 3845

Dimensions

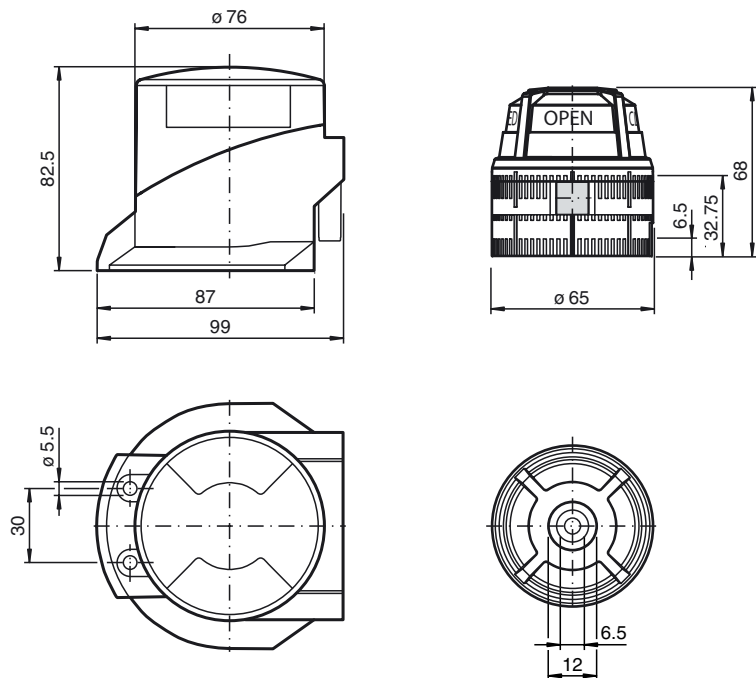

The activator consists of a conductive plastic material which prevents static charging and allows installation in potentially explosive environments.

Release date: 2013-07-08 10:56 Date of issue: 2013-07-08 240225_eng.xml