

Shaft Collars, Clamp Collars, Single-Split - Type GRK with Clamping Lever

Material: Steel C45, black oxide finish.
Stainless steel 1.4305 (AISI 303).
Handle: Zinc die-cast, plastic coated, black.
Screw: Stainless steel 1.4305 (AISI 303).



Features: does not damage the shaft, stronger clamping force than with set collars, even distribution of clamping forces, precise bores. The disengageable, adjustable clamping lever enables an easy readjustment without tools.

Type GRK: With mounting flat and two radial mounting bores, with thread.

Tolerance b: +0.08 mm
-0.25 mm

Temperature resistant up to +90°C.

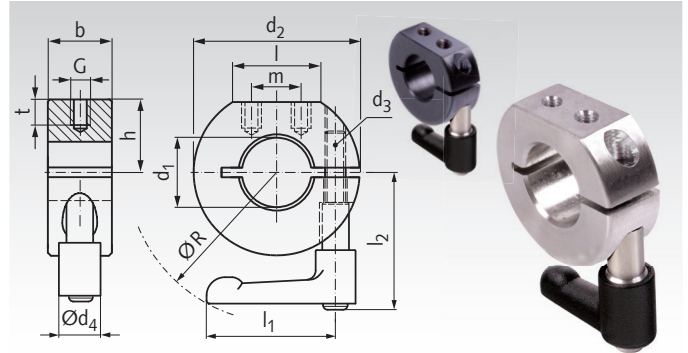

Ordering Details: e.g.: Product No. 623 110 00GRK, Clamp Collar GRK with Clamp Lever, Steel black, 10 mm bore

Product No. Steel black	Product No. Stainless Steel	d ₁ mm	d ₂ mm	b mm	h mm	l _≈ mm	m mm	G mm	t mm	l ₁ mm	l ₂ mm	d ₃ mm	d ₄ mm	R _{max.} mm	Weight g
623 110 00GRK	623 991 10GRK	10	28	9	12	14,5	8	M3	4	22	31,3	M3x10	10,5	70	48
623 112 00GRK	623 991 12GRK	12	30	11	13	15	8	M3	4	30	36,8	M4x12	13	81	70
623 115 00GRK	623 991 15GRK	15	36	13	15	19,5	12	M4	5,5	30	39,3	M5x14	13	88	100
623 116 00GRK	623 991 16GRK	16	38	13	16	20	13	M4	5,5	30	39,3	M5x14	13	89	110
623 120 00GRK	623 991 20GRK	20	42	15	18	21,5	14	M4	5,5	45	45,3	M6x16	13	109	150
623 122 00GRK	623 991 22GRK	22	46	15	20	22,5	12	M4	5,5	45	45,3	M6x16	13	107	174
623 125 00GRK	623 991 25GRK	25	48	15	21	23	12,5	M4	5,5	45	45,3	M6x16	13	106	176
623 130 00GRK	623 991 30GRK	30	56	15	24	28,5	18	M5	7	45	45,3	M6x16	13	108	222
623 135 00GRK	623 991 35GRK	35	60	15	26	30	20	M5	7	45	47,3	M6x18	13	113	235
623 140 00GRK	623 991 40GRK	40	66	15	27	37	27	M5	7	45	47,3	M6x18	13	117	259
623 145 00GRK	623 991 45GRK	45	76	19	31	41,5	28	M6	8,5	78	67,8	M8x25	21	165	516
623 150 00GRK	623 991 50GRK	50	82	19	34,5	43,5	29	M6	8,5	78	67,8	M8x25	21	162	578

Usage

The handle of the lever is disengageable. By lifting the handle, the serrations are disengaged. Now the handle can be turned into the best direction, for tightening, for remaining or loosening. When the lever is released, the serration re-engages automatically because of the spring tension. In re-engaged position, the lever enables the tightening and loosening for an easy positioning of the ring, without tools. Please refer to the safety notes below.

Lever as Spare Part

Singly lever, as a spare part or to be used with other types of clamp rings. More information and other sizes on page 698.

Product No. Clamp Lever	l ₁ mm	d ₃ mm	Weight g
665 783 11	22	M3x10	16
665 784 12	30	M4x12	26
665 785 13	30	M5x14	30
665 786 18	45	M6x16	42
665 786 20	45	M6x18	47
665 788 30	78	M8x25	152

Safety Notes

Use on fixed, non-revolving axles: To avoid an arresting hook, the clamp ring and the lever must be arranged with the handle-end pointing to the sense of rotation of a revolving part nearby. For the required minimum distance from the handle to the next revolving part, eventually existing safety regulations must be regarded.

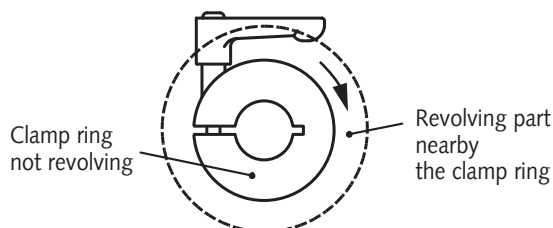

Use on revolving shafts: To avoid an arresting hook, the clamp ring and the lever must be arranged with the handle-end pointing against the sense of rotation of the clamp ring. The revolving speed must be low, so that the lever will not create a big imbalance and centrifugal force. The machine parts must be safeguarded by a cover against access.

