

Grove Shield for Seeeduino XIAO with embedded battery management chip

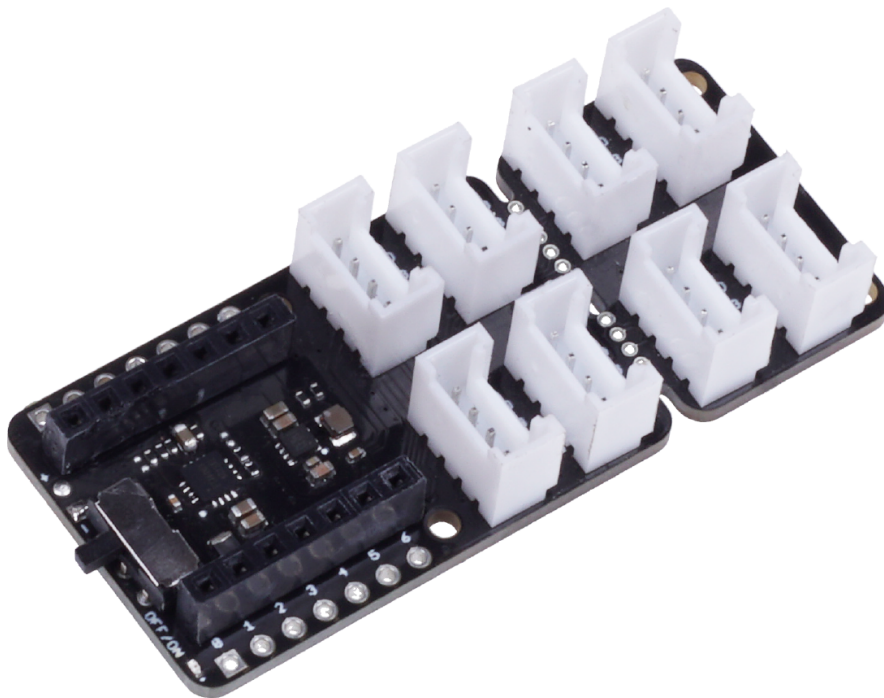

[Get One Now](https://www.seeedstudio.com/Grove-Shield-for-Seeeduino-XIAO-p-4621.html) 

[<https://www.seeedstudio.com/Grove-Shield-for-Seeeduino-XIAO-p-4621.html>]

Grove Shield for Seeeduino XIAO is a plug-and-play Grove extension board for **Seeeduino XIAO** [<https://wiki.seeedstudio.com/Seeeduino-XIAO/>]. With the on-board battery management chip and battery bonding pad, you could easily power your Seeeduino XIAO with lithium battery and recharge it. 8 Grove connectors onboard includes two Grove I2C and one UART. It acts as a bridge for Seeeduino XIAO and Seeed's Grove system. Flash SPI bonding pad allows you add Flash to Seeeduino XIAO to expand its memory space, providing Seeeduino XIAO with more possibilities.

With the on-board battery management chip and battery bonding pad, you could easily power your Seeeduino XIAO with lithium 3.7V battery and recharge it, making your projects, especially wearables ones, more flexible and in portable. You could even break the board through the onboard PCB stamp holds according to your actual needs of the project (only 25*39mm in dimension after break-off), making it smaller than smaller and the weight would be reduced from 13g to 10g as well!



As an extension board, the Grove Shield for Seeeduino XIAO also pulls all 14 pinout from Seeeduino XIAO, and its on-board power switch and charging status indicator light makes it more user-friendly. The Shield even reserves the SPI-Flash bonding pad for an advanced developer who may need to add Flash to Seeeduino XIAO to expand its memory space, providing Seeeduino XIAO with more possibilities.

As XIAO form factor, all XIAO boards support both **Grove Shield for XIAO** [<https://www.seeedstudio.com/Seeeduino-XIAO-Expansion->

board-p-4746.html] and [XIAO Expansion board](#) [https://www.seeedstudio.com/Seeeduino-XIAO-Expansion-board-p-4746.html]. There is a slight difference between the pins and refer to the Pinout it is easy to manage.

**Note**

This product does not include a Seeeduino XIAO, please click [here](#) [https://www.seeedstudio.com/Seeeduino-XIAO-Arduino-Microcontroller-SAMD21-Cortex-M0+-p-4426.html] if you need one.

Feature

- On-board Lithium Battery Charging and Management Function
- Grove connectors (Grove IIC x 2, Grove UART x 1), all 14 GPIO led out
- Compact and Breakable Design
- Flash SPI Bonding Pad Reserved
- On-board Power Switch and Charging Status Indicator Light

Specification

Item	Value
Operating voltage	3.3V / 3.7V Lithium Battery
Load Capacity	800mA
Charging current	400mA (Max)
Operating Temperature	- 40°C to 85°C
Storage Temperature	-55°C to 150°C
Grove Interface	I2C * 2 / UART * 1

Applications

- Wearable devices
- Rapid prototyping
- Grove modules testing
- Projects require small size

Platform Supported

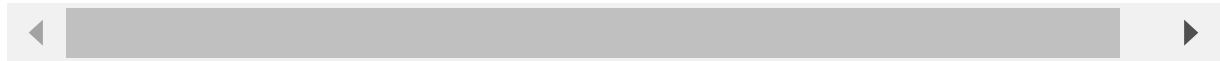
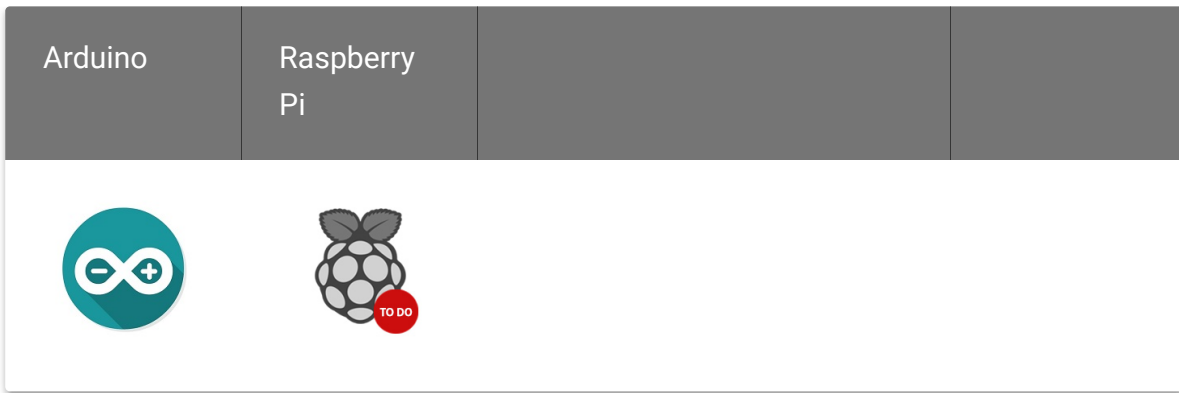

Getting Started

Materials Required

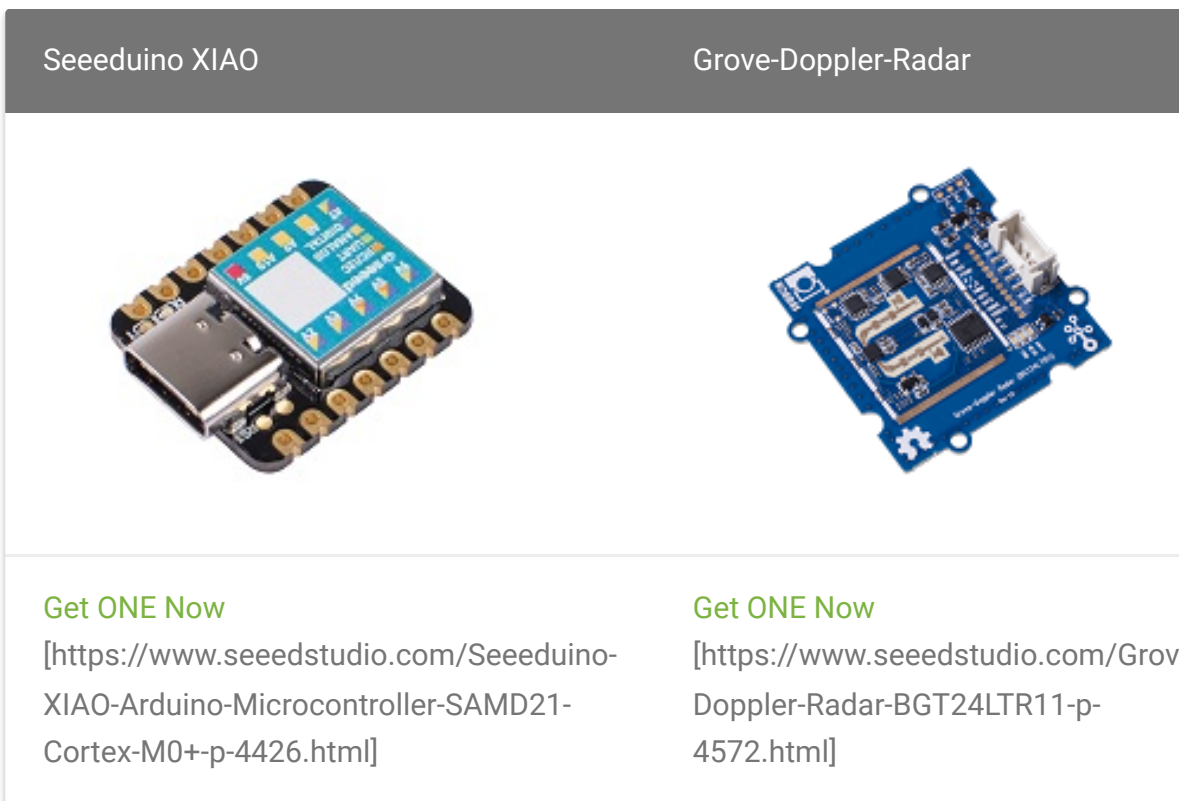

Hardware Overview

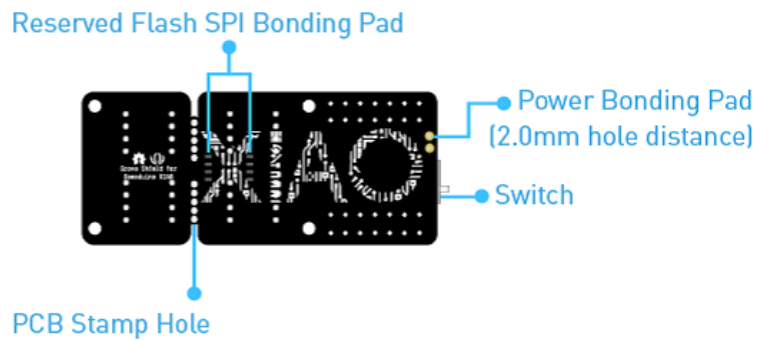
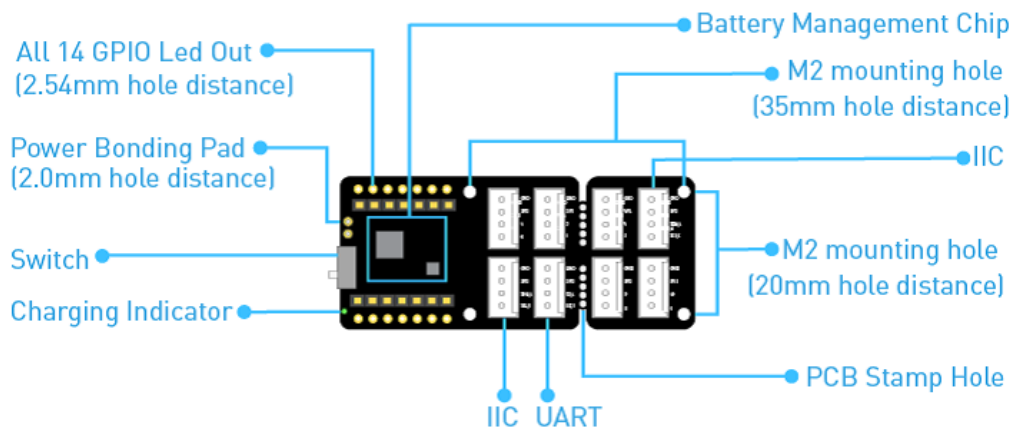

[target="_blank"]

If you need use the back of the Xiao Grove Shield provisions pads for a Flash memory in SOIC8 package, please soldering the PIN1.

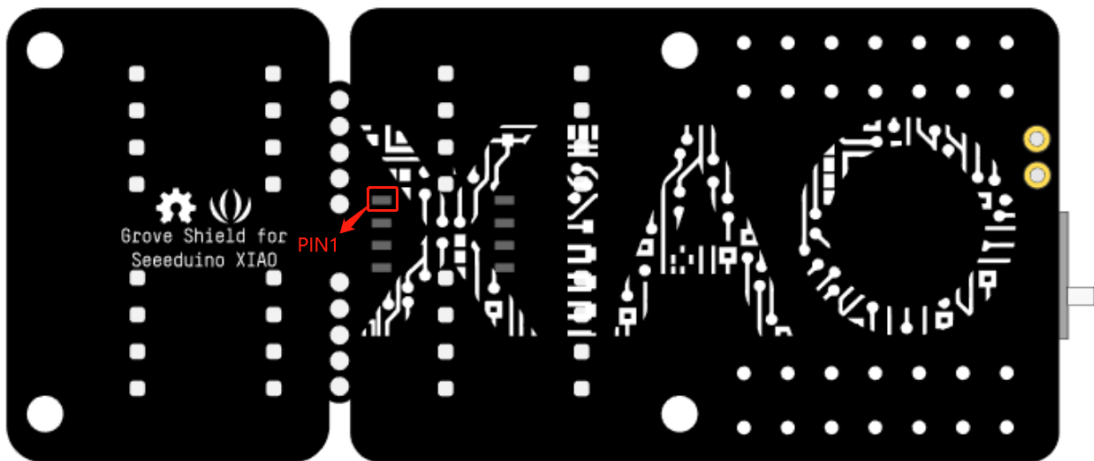

[target="_blank"]

External headers-pin description for Grove-Shield for Seeeduino XIAO

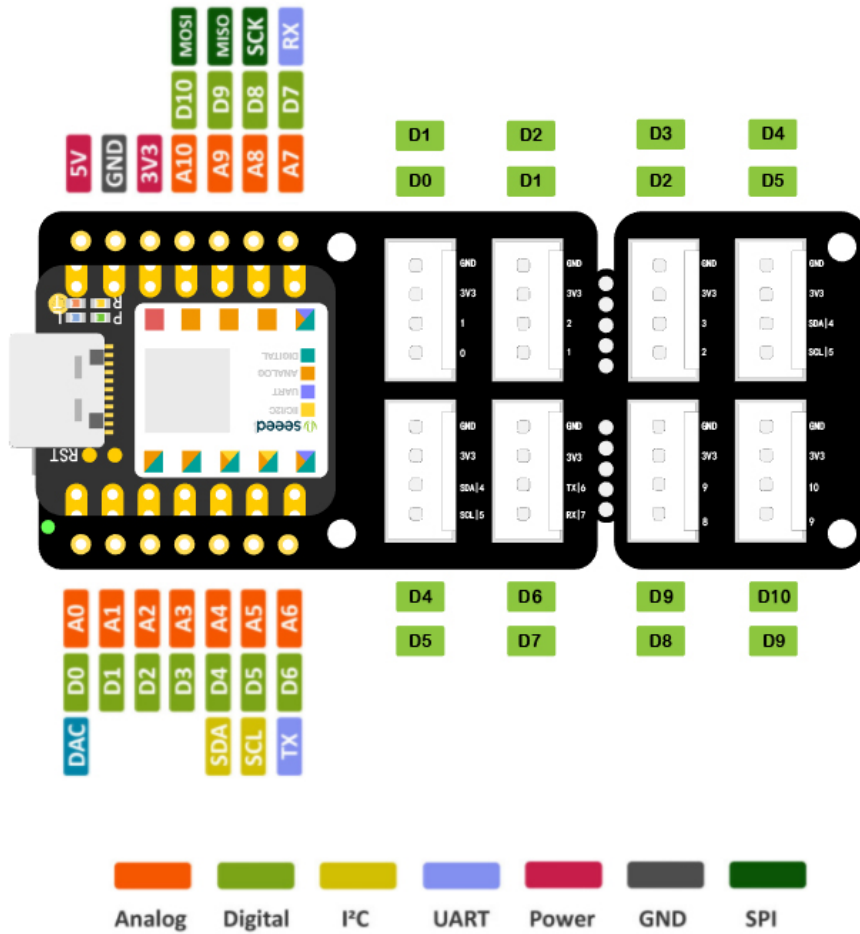

[target="_blank"]

External headers-pin description for Grove-Doppler Radar

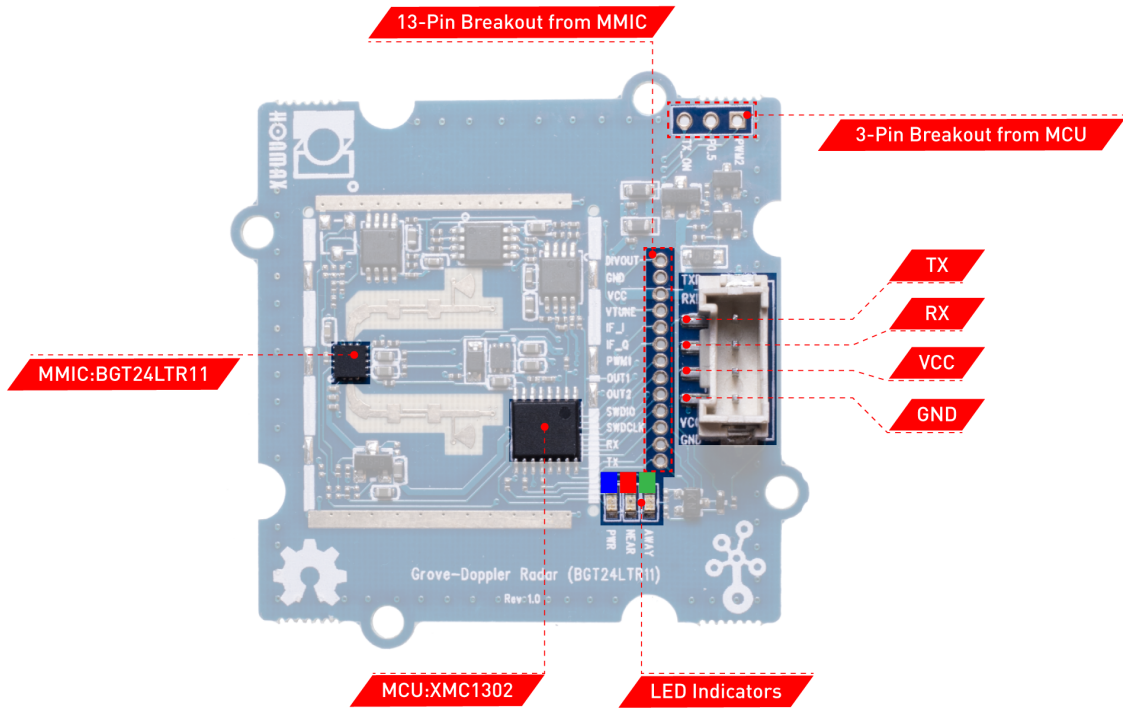

Pin number	Signal name	Pin description
1	DIV_OUT	Frequency divider output from the BGT24LTR11
2	GND	Ground
3	VCC_5V_EXT	External+5.0V input power supply pin(maximum=5.5V)
4	VTUNE	VCO frequency tuning voltage
5	IFQ_HG	BGT24LTR11 Q-channel-analog signal output-second gain stage
6	IFI_HG	BGT24LTR11 I-channel-analog signal output-second gain stage
7	PWM_OUT	External user-configurable GPIO with CCU4
8	OUT1	External GPIO pin (user configurable)
9	OUT2	External GPIO pin (user configurable)

Hardware Connection

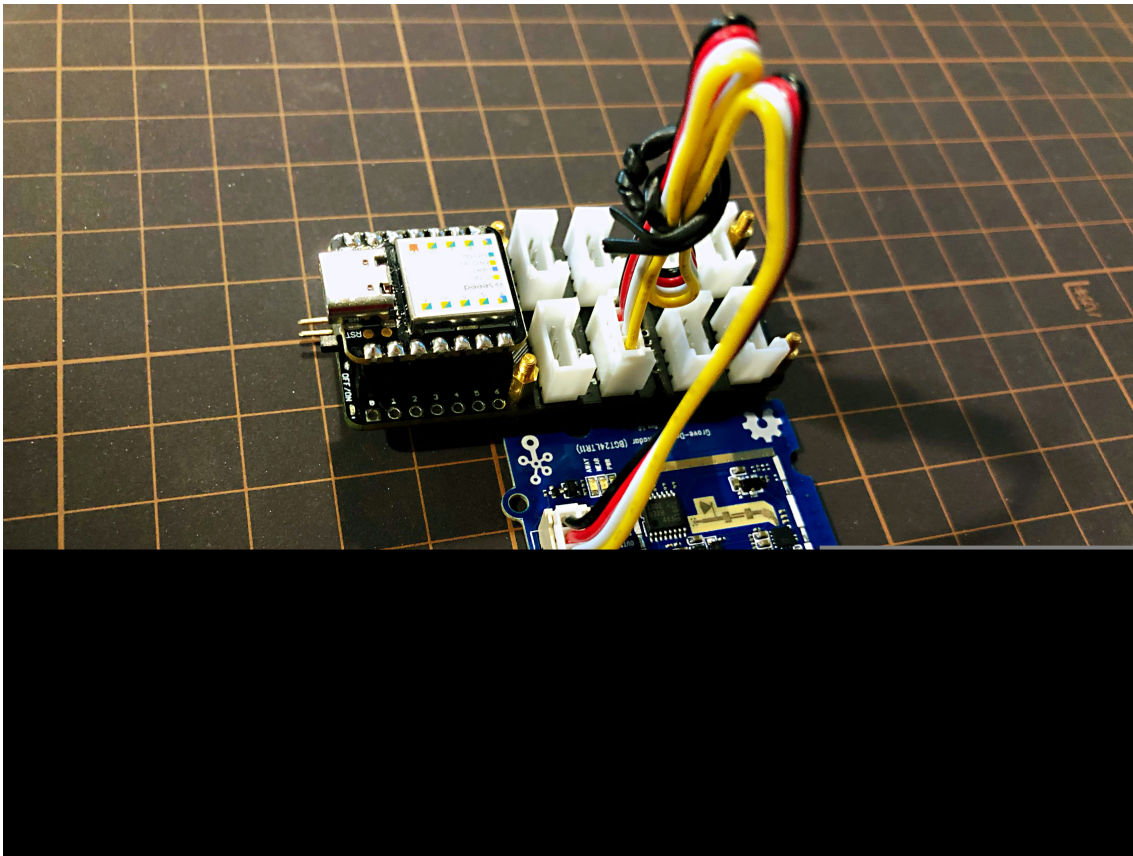

Tip

Please plug the USB cable, Doppler Radar Interface into Seeeduino XIAO expansion board Interface gently, otherwise you may damage the port.

- **Step 1.** Plug Doppler Radar into Seeeduino XIAO expansion board with a Grove Cable.
- **Step 2.** Connect Seeeduino XIAO to PC via a USB cable.
- **Step 3.** Download the code, please refer to the software part.
- **Step 4.** Run the code and the outcome will display on the screen of **Serial Monitor** in your Arduino IDE .

Software



Attention

If this is the first time you work with Arduino, we strongly recommend you to see [Getting Started with Arduino](https://wiki.seeedstudio.com/Getting_Started_with_Arduino/) [https://wiki.seeedstudio.com/Getting_Started_with_Arduino/] before the start.

- **Step 1.** Download the [Demo code](#) [https://files.seeedstudio.com/wiki/Grove-Doppler-Radar/Seeed_Arduino_DopplerRadar.rar].
- **Step 2.** Copy the whole **Seeed_Arduino_DopplerRadar** file and paste it into your Arduino IDE library file.
- **Step 3.** Open the **BGT24LTR11_DETECTION_TARGET** file with your Arduino IDE.
- **Step 4.** Upload the demo. If you do not know how to upload the code, please check [How to upload code](#) [https://wiki.seeedstudio.com/Upload_Code/].

Software Code

```
1  #include "GBT24LTR11.h"
2
3  #ifdef __AVR__
4      #include <SoftwareSerial.h>
5      SoftwareSerial SSerial(2, 3); // RX, TX
6      #define COMSerial SSerial
7      #define ShowSerial Serial
8
9      GBT24LTR11<SoftwareSerial> GBT;
10 #endif
11
12 #ifdef ARDUINO_SAMD_VARIANT_COMPLIANCE
13     #define COMSerial Serial1
14     #define ShowSerial SerialUSB
15
16     GBT24LTR11<Uart> GBT;
```



```
17 #endif
18
19 #ifdef ARDUINO_ARCH_STM32F4
20     #define COMSerial Serial
21     #define ShowSerial SerialUSB
22
23     GBT24LTR11<HardwareSerial> GBT;
24 #endif
25
26 void setup() {
27     // put your setup code here, to run once:
28     ShowSerial.begin(9600);
29     COMSerial.begin(115200);
30     GBT.init(COMSerial);
31     while (!ShowSerial)
32         ;
33     while (!COMSerial)
34         ;
35     /*
36         MODE 0 -->detection target mode
37         MODE 1 -->I/Q ADC mode
38     */
39     while (!GBT.setMode(0))
40         ;
41 }
42
43 void loop() {
44     // put your main code here, to run repeatedly:
45     uint16_t state = 0;
46     ShowSerial.print("target speed:");
47     ShowSerial.println(GBT.getSpeed());
48     state = GBT.getTargetState();
49     //2 --> target approach
50     //1 --> target Leave
51     //0 --> Not Found target
52     if (state == 2) {
53         ShowSerial.println("target approach");
54     } else if (state == 1) {
55         ShowSerial.println("target leave");
56     }
57     delay(200);
}
```

58 }

**Success**

If everything goes well, you can go to **Serial Monitor** to see an outcome as following:

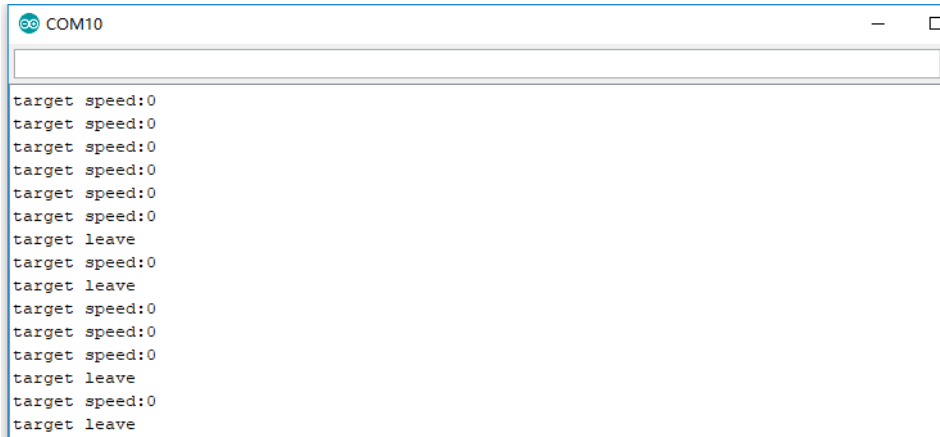

```
target speed:0
target speed:0
target speed:0
target speed:0
target speed:0
target speed:0
target speed:0
target leave
target speed:0
target leave
target speed:0
target speed:0
target speed:0
target leave
target speed:0
target leave
```

Figure 3. *No object approaching*

And if there's an object approaching the radar or passing by, the outcome will alter as below:

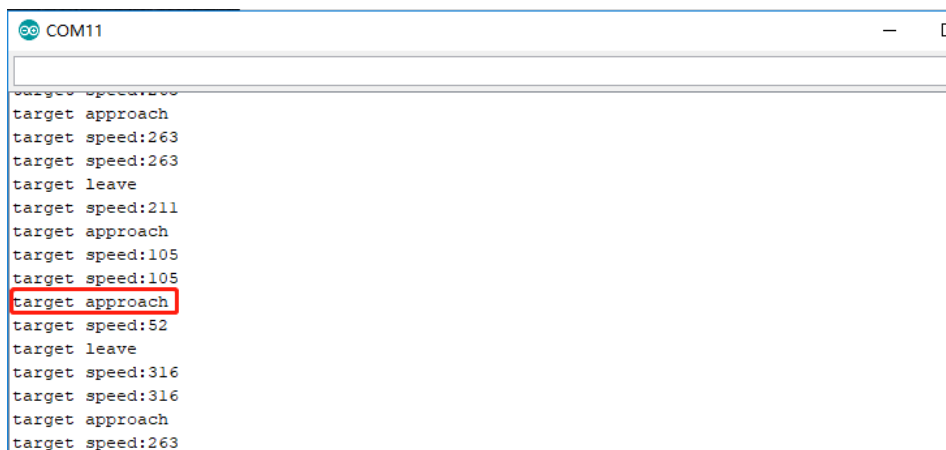

```
target speed:0
target approach
target speed:263
target speed:263
target leave
target speed:211
target approach
target speed:105
target speed:105
target approach
target speed:52
target leave
target speed:316
target speed:316
target approach
target speed:263
```

Figure 3. *Object approaching*

**Note**

The minimum speed accuracy that the sensor is capable of detecting is 52cm/s, which equals to 0.52m/s, 3.6km/h and 2.23mph. Additionally, the

results returned by function `getSpeed()` are multiples of 52cm/s and are absolute values accordingly.

Schematic Online Viewer



Resources

- **[ZIP]** [Attachment of Grove Shield for Seeeduino XIAO](https://files.seeedstudio.com/wiki/Grove-Shield-for-Seeeduino-)
[<https://files.seeedstudio.com/wiki/Grove-Shield-for-Seeeduino->

XIAO/res/Grove_Shield_for_Seeduino_XIAO_v1.0.zip]

- **[ZIP]** [Demo Code library](#)
[https://files.seeedstudio.com/wiki/Grove-Doppler-Radar/Seeed_Arduino_DopplerRadar.zip]
- **[PDF]** [Grove DopplerRadar \(BGT24LTR11\) Radar module communication protocol v1.1.pdf](#)
[https://files.seeedstudio.com/wiki/Grove-Doppler-Radar/Grove_DopplerRadar(BGT24LTR11)Radar_module_communication_protocol_v1.1.pdf]
- **[PDF]** [ETA 3410 Datasheet](#)
[https://files.seeedstudio.com/wiki/Grove-Shield-for-Seeeduino-XIAO/res/ETA3410.pdf]

Project



Tech Support

Please submit any technical issue into our [forum](#)

[<http://forum.seeedstudio.com/>].



[https://www.seeedstudio.com/act-4.html?utm_source=wiki&utm_medium=wikibanner&utm_campaign=newproducts]