

Eclipse Z7 Hardware Reference Manual

The Eclipse Z7 is a powerful prototyping platform, featuring Xilinx's Zynq-7000 APSoC. A SYZYGY™ compatible carrier board, it features two SYZYGY™ interface connectors, enabling high speed modular systems.

Eclipse is designed to enable high speed analog data capture and analysis. It is a platform for research and rapid prototyping of test and measurement applications, potentially including software-defined radio, ultrasound, other medical devices, and much more. As a host board for Zmods (<https://digilent.com/reference/zmod/start>), applications for the Eclipse can vary significantly between system configurations.

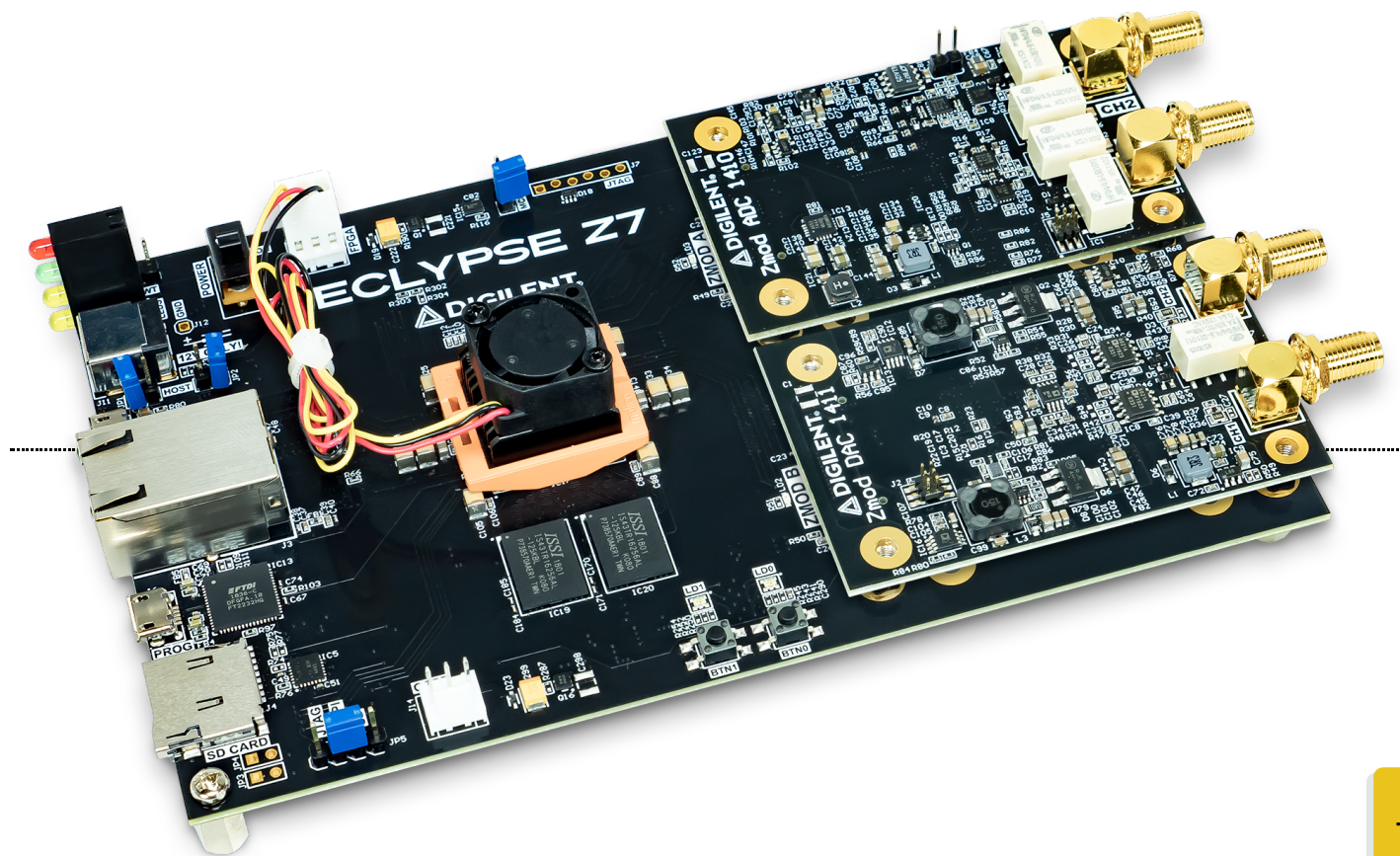

(https://digilent.com/reference/_media/reference/programmable-logic/eclipse-z7/reference-manual/eclipse-obpopulated-2000.png)

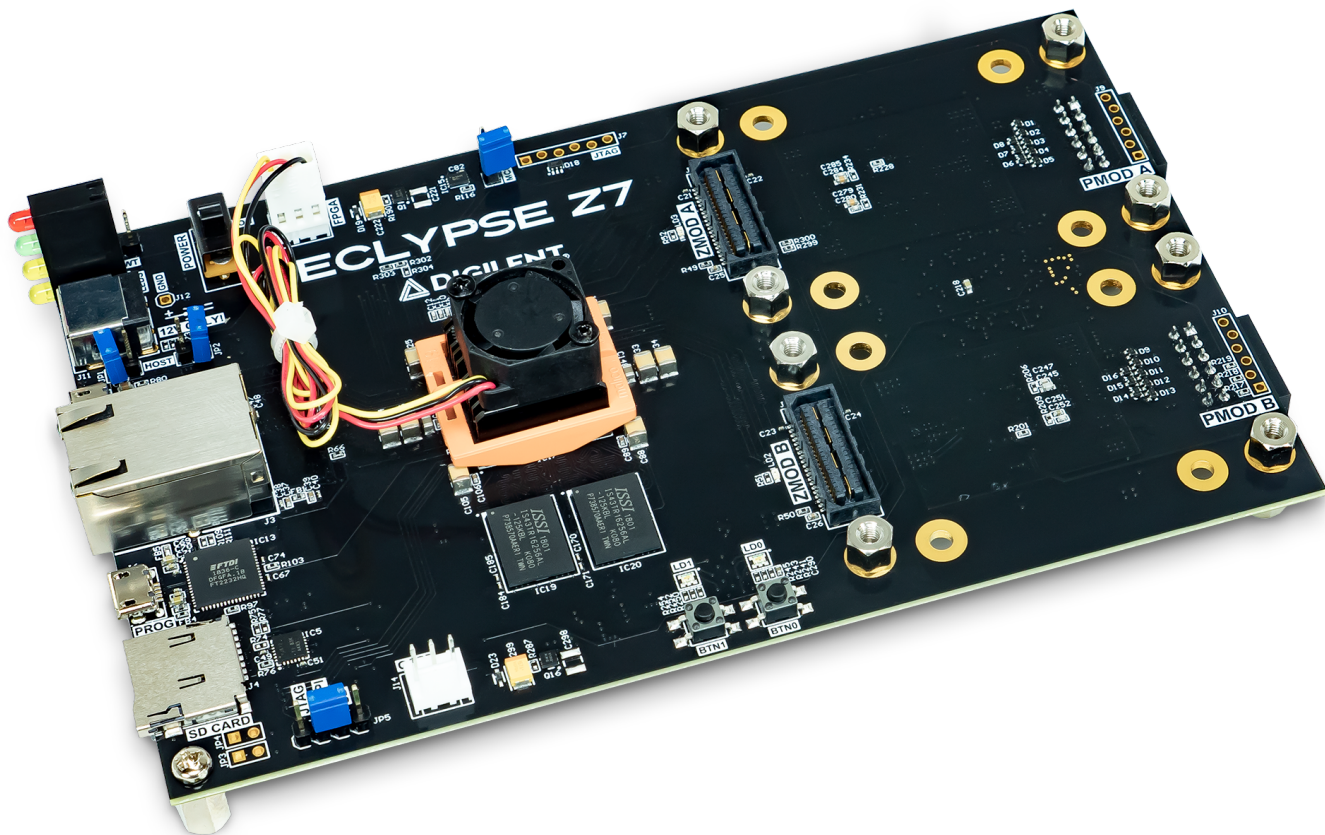
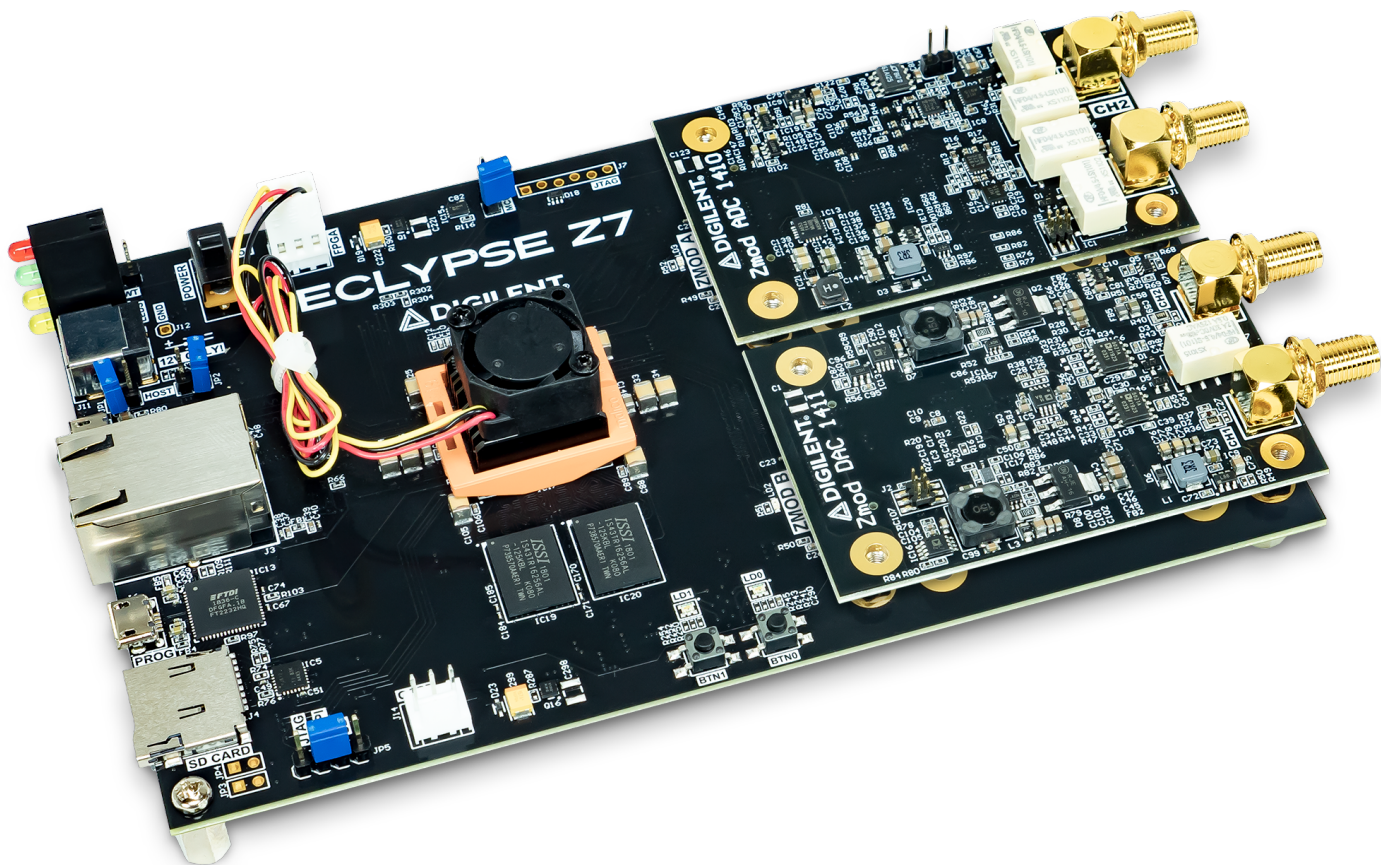

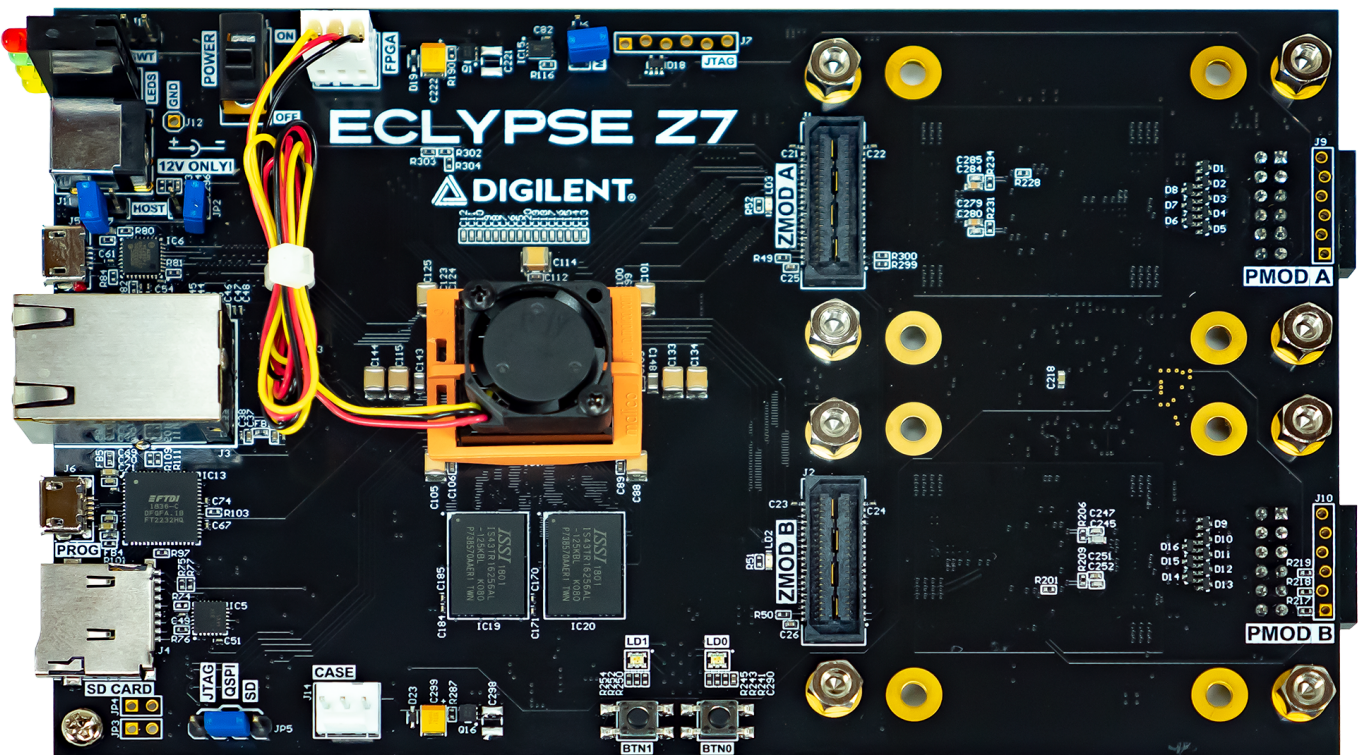
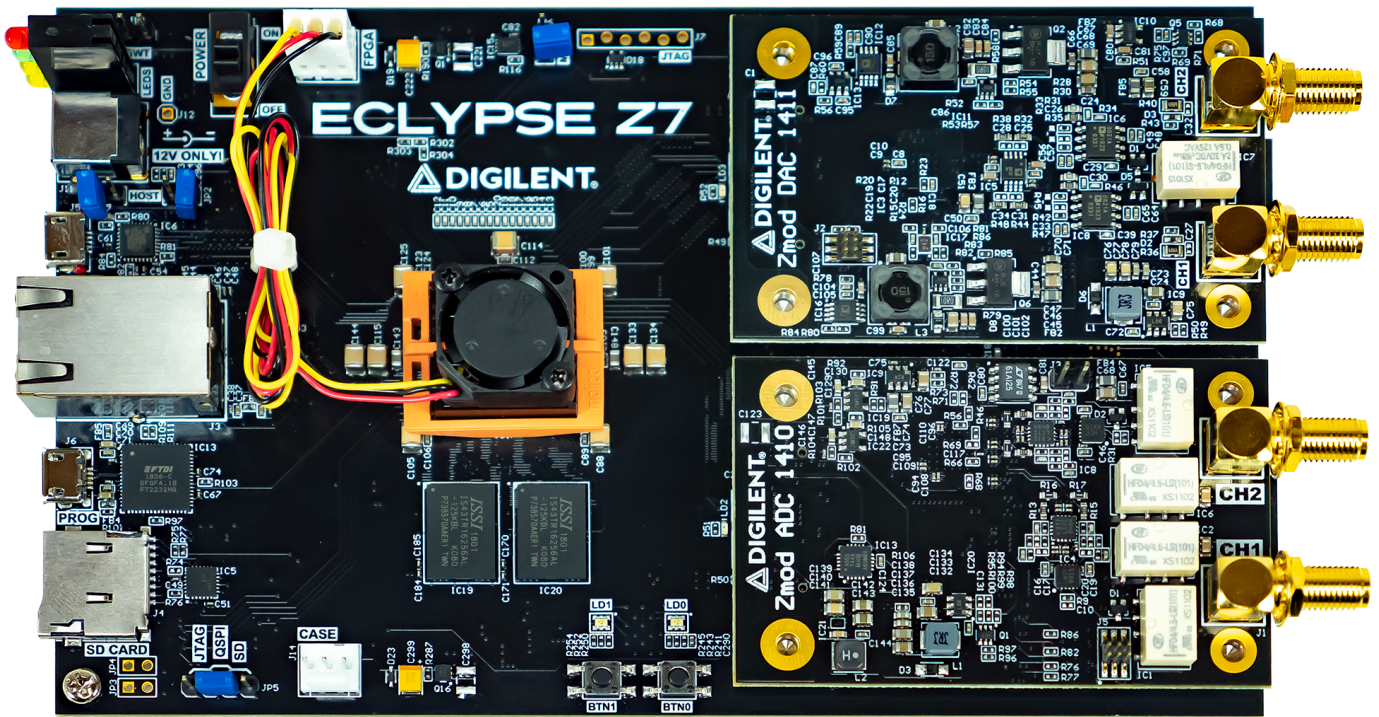

Features

- **Zynq-7000 APSoC (XC7Z020-1CLG484C)**
 - 667 MHz dual-core Cortex-A9 processor
 - DDR3L memory controller with 8 DMA channels and 4 High Performance AXI3 Slave ports
 - High-bandwidth peripheral controllers: 1G Ethernet, USB 2.0, SDIO
 - Low-bandwidth peripheral controllers: SPI, UART, CAN, I2C

- Programmable from JTAG, Quad-SPI flash, and microSD card
 - Programmable logic equivalent to Artix-7 FPGA
 - **Memory**
 - 1 GiB DDR3L with 32-bit bus @ 1066 MT/s
 - 16 MB Quad-SPI Flash with a factory-programmed 48-bit globally unique EUI-48/64™ compatible identifier
 - microSD card slot
 - **Power**
 - Powered from external 12V 5A supply
 - Platform MCU for configuration of adjustable power supplies and temperature management
 - **USB and Ethernet**
 - Gigabit Ethernet PHY
 - USB-JTAG programming circuitry
 - USB-UART bridge
 - USB micro AB port with USB 2.0 PHY with Host/Device/OTG capabilities
 - **Zmod Ports**
 - 2 ports following the SYZYGY™ Standard interface specification
 - Compatible with a variety of SYZYGY™ pods, allowing for a wide variety of applications
 - Dedicated differential clocks for input and output
 - 8 differential I/Os per port
 - 16 single-ended I/Os per port
 - DNA interfaces connected to Platform MCU allowing for various auto-negotiated power supply configurations
 - **Pmod Ports**
 - 2 twelve-pin ports for a total of 16 FPGA-connected I/Os
 - High speed voltage translation and protection circuitry
 - **User GPIO**
 - 2 push-buttons
 - 2 RGB LEDs
-

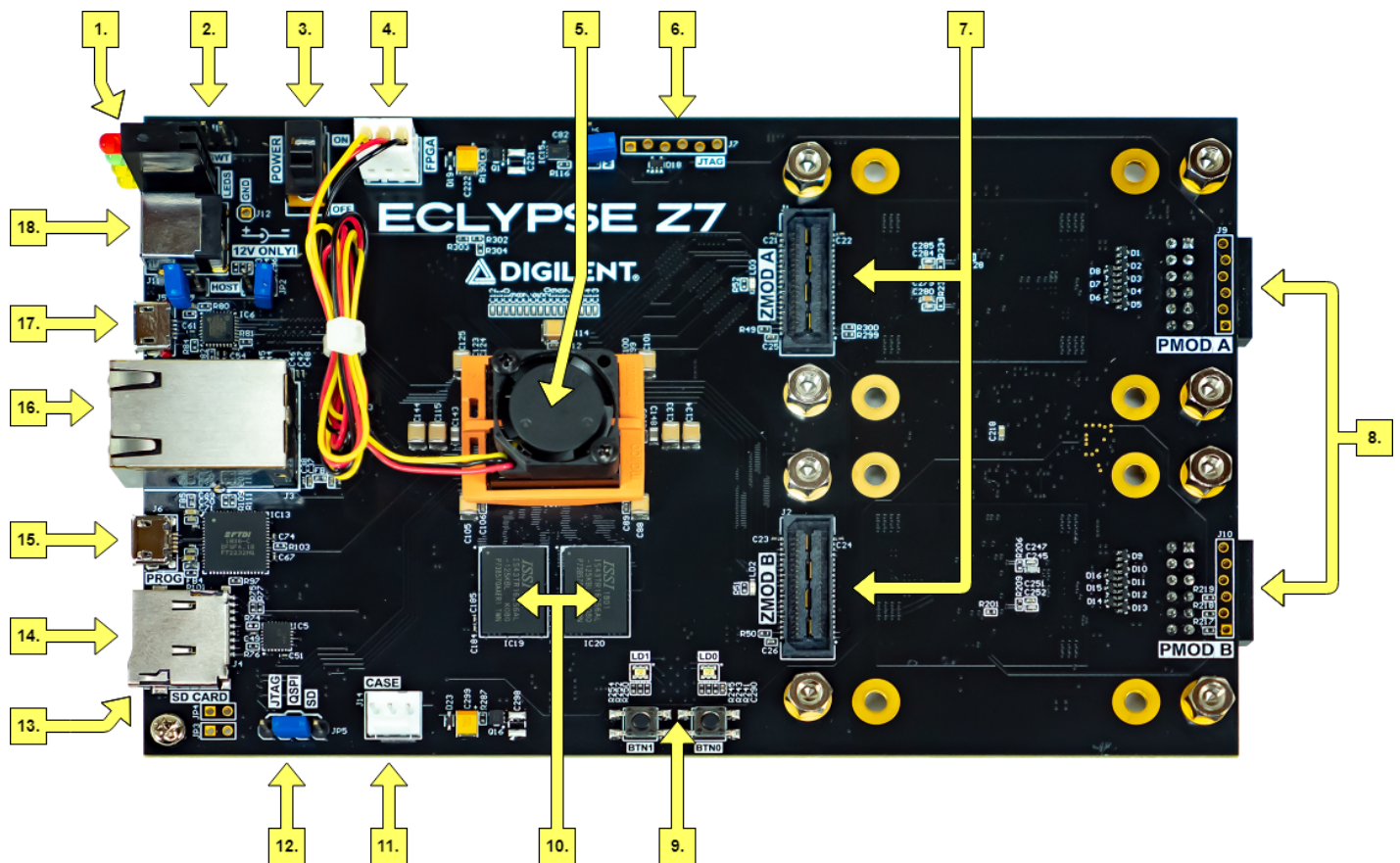

(https://digilent.com/reference/_detail/reference/programmable-logic/eclipse-z7/reference-manual/eclipse-callout.png?id=programmable-logic%3Aeclipse-z7%3Areference-manual) *Eclipse Z7 Callout Diagram*

Callout #	Description	Callout #	Description	Callout #	Description
1	Board Indicator LEDs (LD4)	7	SYZYGY™ Ports	13	Reset Buttons (underside of board)
2	Header for Case Power Switch	8	Pmod Ports	14	microSD Card Slot
3	Power Switch	9	User Buttons and LEDs	15	USB JTAG/UART Port
4	FPGA Fan Header	10	DDR3L Memory	16	Ethernet Port
5	Zynq-7000 SoC and FPGA Fan	11	Case Fan Header	17	USB AB Host/Device/OTG Port

Callout #	Description	Callout #	Description	Callout #	Description
6	External JTAG Port	12	Programming Mode Select Jumper	18	Power Supply Connector

Purchasing Options

The Eclipse Z7 includes an FPGA fan to dissipate extra heat generated from running complex fast-switching designs. A USB A to Micro B programming cable, a USB A to Micro A cable, and a 12V 5A power supply, are included with the Eclipse Z7.

An Eclipse Z7 Enclosure Kit may optionally be added on, which provides a sturdy case for the Eclipse platform. The Enclosure Kit includes a case fan for additional cooling, and exposes the connectors of loaded Zmod ADCs and DACs, as well as the Eclipse Z7's Pmod expansion connectors, power switch, status LEDs, and more.

For more information on purchasing an Eclipse Z7, see the [Eclipse Z7 Product Page](https://digilent.com/shop/eclipse-z7-zynq-7000-soc-development-board-with-syzygy-compatible-expansion/) (<https://digilent.com/shop/eclipse-z7-zynq-7000-soc-development-board-with-syzygy-compatible-expansion/>).

Digilent Zmods (<https://digilent.com/reference/zmod/start>) may also be purchased individually or bundled with the Eclipse Z7. Expansion connectors such as these, or other SYZYGY™ modules, are required to fully leverage the high-speed I/O capabilities of the Eclipse platform.

Software Support

Zynq platforms are well-suited to be embedded Linux targets, and the Eclipse Z7 is no exception. Digilent provides software examples targeting custom Petalinux projects, including support for each Digilent Zmod for high-speed I/O capabilities.

The Eclipse Z7 is fully compatible with Xilinx's high-performance Vivado® Design Suite. This tool set melds FPGA logic design and embedded ARM software development into an easy to use, intuitive design flow. It can be used for designing systems of any complexity, from a complete operating system running multiple server applications, down to a simple bare-metal program that controls some LEDs. It is also possible to treat the Zynq AP SoC as a standalone FPGA for those not interested in using the processor in their design. The Eclipse Z7 is supported under Vivado's free WebPACK™ license, which means the software is completely free to use, including the Logic Analyzer and High-level Synthesis (HLS) features. The Logic Analyzer assists with debugging logic that is running in hardware, and the HLS tool allows C code to be directly compiled into HDL.

The Eclipse is also supported by Digilent's mature WaveForms software package, which provides an straightforward path for first acquisitions, a variety of complex software instruments in application software, and software-based workflows using the WaveForms Software Development Kit (SDK). For

more information, check out this guide: [Using the Eclipse Z7 with WaveForms](https://digilent.com/reference/programmable-logic/eclipse-z7/waveforms) (<https://digilent.com/reference/programmable-logic/eclipse-z7/waveforms>).

Digilent currently does not provide hardware platforms or examples for Xilinx's Vitis Unified Software Platform, however Vitis support is planned for the near future.

Design resources, example projects, and tutorials are available for download at the [Eclipse Z7 Resource Center](https://digilent.com/reference/programmable-logic/eclipse-z7/start) (<https://digilent.com/reference/programmable-logic/eclipse-z7/start>).

Zynq APSoC Architecture

The Zynq APSoC is divided into two distinct subsystems: The Processing System (PS) and the Programmable Logic (PL). The figure below shows an overview of the Zynq APSoC architecture, with the PS colored light green and the PL in yellow. Note that the PCIe Gen2 controller and Multi-gigabit transceivers are not available on the Zynq-7020 device.

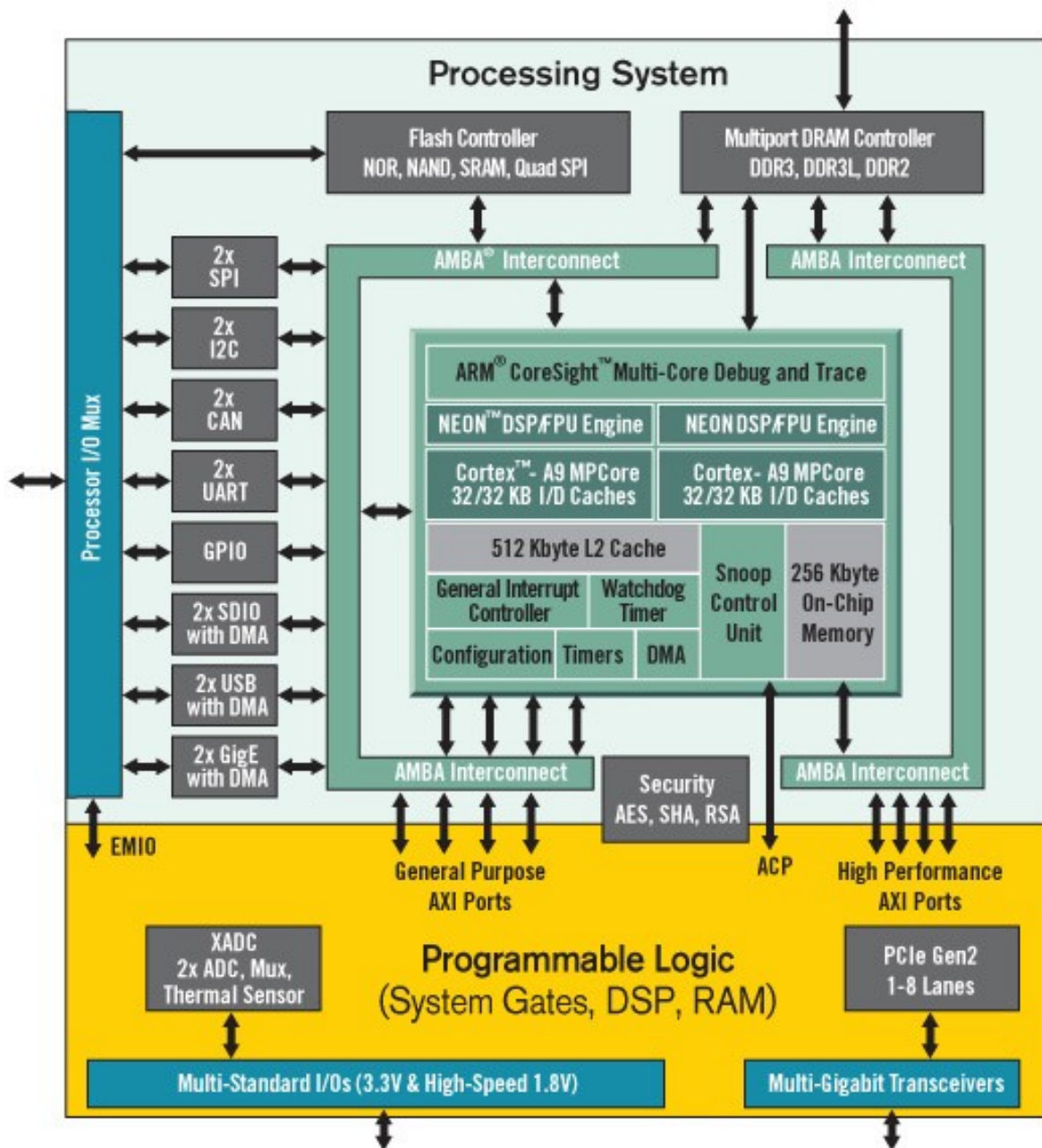

(https://digilent.com/reference/_detail/zybo/zyng1.png?id=programmable-logic%3Aeclipse-z7%3Areference-manual)

The PL is nearly identical to a Xilinx 7-series Artix FPGA, except that it contains several dedicated ports and buses that tightly couple it to the PS. The PL also does not contain the same configuration hardware as a typical 7-series FPGA, and it must be configured either directly by the processor or via the JTAG port.

The PS consists of many components, including the Application Processing Unit (APU, which includes 2 Cortex-A9 processors), Advanced Microcontroller Bus Architecture (AMBA) Interconnect, DDR3 Memory controller, and various peripheral controllers with their inputs and outputs multiplexed to 54 dedicated pins (called Multiplexed I/O, or MIO pins). Peripheral controllers that do not have their inputs and outputs connected to MIO pins can instead route their I/O through the PL, via the Extended-MIO (EMIO) interface. The peripheral controllers are connected to the processors as slaves via the AMBA interconnect, and contain readable/writable control registers that are addressable in the processors' memory space. The programmable logic is also connected to the interconnect as a slave, and designs can

implement multiple cores in the FPGA fabric that each also contain addressable control registers. Furthermore, cores implemented in the PL can trigger interrupts to the processors and perform DMA accesses to DDR3 memory.

There are many aspects of the Zynq APSoC architecture that are beyond the scope of this document. For a complete and thorough description, refer to the [Zynq Technical Reference manual \(https://docs.xilinx.com/v/u/en-US/ug585-Zynq-7000-TRM\)](https://docs.xilinx.com/v/u/en-US/ug585-Zynq-7000-TRM).

The tables in the dropdowns below depict the external components connected to the MIO pins of the Eclipse Z7. The Vivado board files found on the [Eclipse Z7 Resource Center \(https://digilent.com/reference/programmable-logic/eclipse-z7/start\)](https://digilent.com/reference/programmable-logic/eclipse-z7/start) can be used to properly configure the PS to work with these peripherals. It is also possible to use the example projects found on the resource center as a starting point for custom designs.

MIO 0-15 : Bank 500

MIO 500 3.3 V	Peripherals				
Pin	GPIO_0	SPI Flash	ENET 0	SYZYGY	UART 0
0 (N/C)					
1		CS_0			
2		DQ0			
3		DQ1			
4		DQ2			
5		DQ3			
6		SCLK_0			
7 (N/A)					
8		SCLK_0 FB			
9			Ethernet Reset		
10 (N/A)					
11 (N/A)					
12				DNA SCL (I2C 1)	

13				DNA SDA (I2C 1)	
14					UART Input
15					UART Output

MIO 16-53 : Bank 501

MIO 501 1.8V	Peripherals			
Pin	ENET 0	USB 0	SD 0	
16	TXCK			
17	TXD0			
18	TXD1			
19	TXD2			
20	TXD3			
21	TXCTL			
22	RXCK			
23	RXD0			
24	RXD1			
25	RXD2			
26	RXD3			
27	RXCTL			
28		DATA4		
29		DIR		
30		STP		

31		NXT	
32		DATA0	
33		DATA1	
34		DATA2	
35		DATA3	
36		CLK	
37		DATA5	
38		DATA6	
39		DATA7	
40			CCLK
41			CMD
42			D0
43			D1
44			D2
45			D3
46		USB Reset	
47			CD
48	Ethernet Interrupt (GPIO_0)		
49		USB Overcurrent (GPIO_0)	
50 (N/C)			
51 (N/C)			

52	MDC		
53	MDIO		

Functional Description

1. Power Supplies

The Eclipse Z7 power circuitry was carefully designed to meet the requirements of the Zynq-7000 and all peripherals while providing the flexibility needed to power a variety of different configurations of Zmod/SYZYGY modules.

An overview of the power circuit is shown in Figure 1.1.

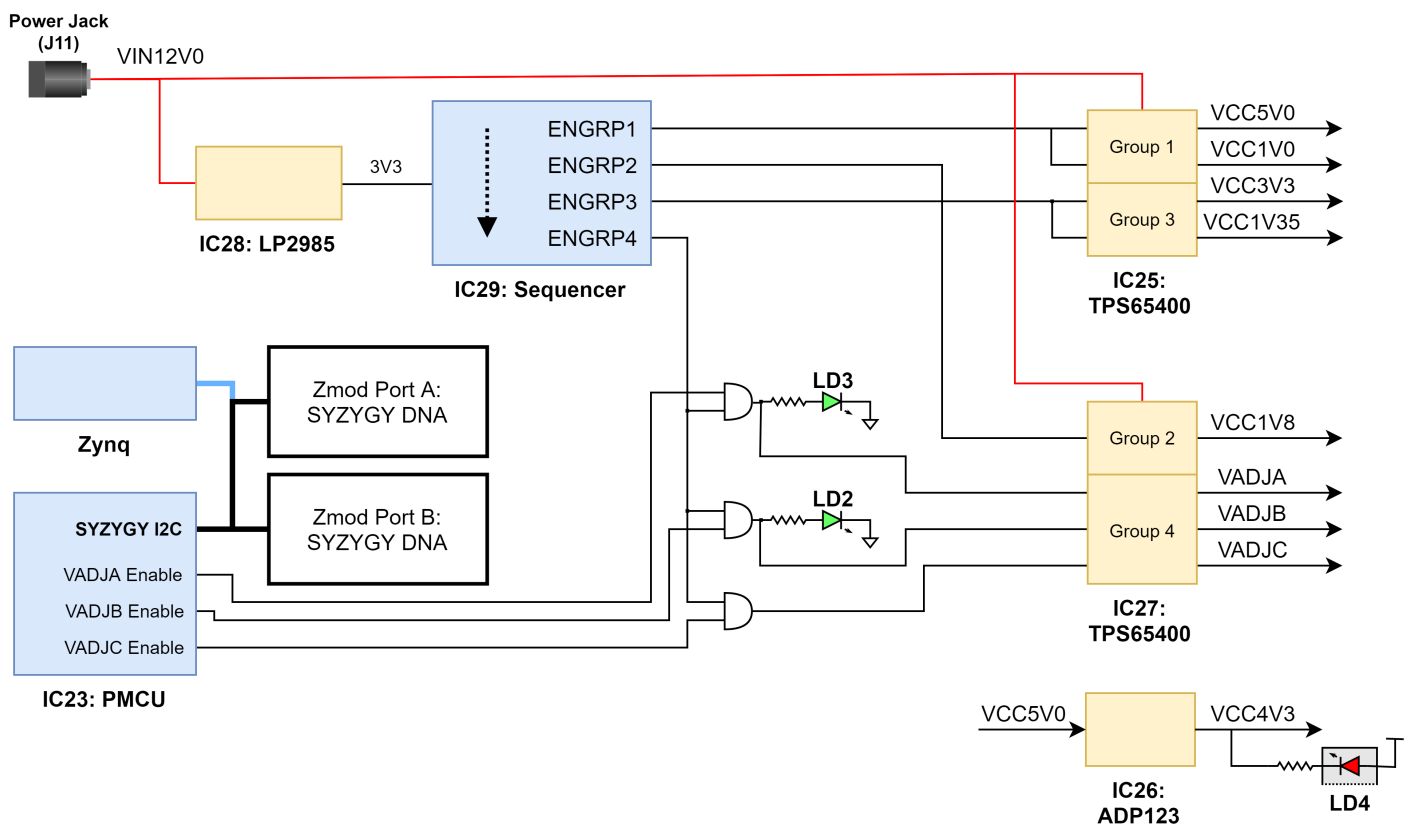

(https://digilent.com/reference/_detail/reference/programmable-logic/eclipse-z7/reference-manual/eclipse-power.png?id=programmable-logic%3Aeclipse-z7%3Areference-manual)

Figure 1.1: Power circuit overview

All on-board power supplies are enabled or disabled by the power switch (SW1) or by an external SPST switch connected to the SW1 header (J13).

Note: If an external switch is used, SW1 should be placed in the “OFF” position, as the two will be placed in parallel.

The power indicator LED, the topmost LED of the circuit board indicator (LD4), is illuminated red when all supply rails reach their nominal voltage.

Two additional indicator LEDs are illuminated when the VIO supplies associated with the two Zmod Ports are powered. LD2 is associated with Zmod Port A and the VADJA rail. LD3 is associated with Zmod Port B and the VADJB rail.

1.1. Power Input Source

The Eclipse Z7 should be powered via a wall wart supply with barrel jack, via the barrel connector (J11). The supply must use a center-positive 2.1 mm internal-diameter plug and deliver between 11.5V and 12.5V DC. It should also be able to provide at least 5 A (60 Watts) in order to support power hungry Zynq projects and external peripherals. A compatible power supply ships with the Eclipse Z7.

Table 1.1.1: Eclipse Z7 Power Input Specifications

Connector Type	Connector Label	Schematic Net Name	Min/Rec/Max Voltage (V)	Max Current Consumption
Barrel jack	J11	VIN12V0	11.5/12/12.5	5 A / 60 W

1.2. Power Specifications

Table 1.2.1 describes the characteristics of the Eclipse Z7's on-board power rails. It can be used to estimate power consumption for a project, or determine how much current attached peripherals can draw before being limited.

Table 1.2.1: Eclipse Z7 Power Rail Specifications

Net Name	Upstream Net Name	Power IC Type	Power IC Label	Min/Typ/Max Voltage	Max. Current	Major Devices and Connectors
VCC5V0	VIN12V0	Buck	IC27	5.0V +-5%	3A	Zmods, USB OTG VBUS, RGB LEDs, Case Fan
VCC1V0	VIN12V0	Buck	IC27	1.0V +-5%	1A	Zynq, Ethernet, USB OTG, USB JTAG/UART, microSD
DDR1V35	VIN12V0	Buck	IC25	1.35V +-5%	2A	Zynq, DDR3L
DDRVTT	VIN12V0	LDO	IC21	0.675V +-5%	0.45A	DDR3L

Net Name	Upstream Net Name	Power IC Type	Power IC Label	Min/Typ/Max Voltage	Max. Current	Major Devices and Connectors
VCC3V3	VIN12V0	Buck	IC25	3.3V +-5%	3.3A	Zynq, Zmods, Pmods, USB OTG, USB JTAG/UART, microSD
VCC4V3	VCC5V0	LDO	IC26	4.3V +-5%	0.3A	Pmods
VADJA	VIN12V0	Buck	IC27	1.2V to 3.3V; +-5%	1.8A	FPGA, Zmod Port A
VADJB	VIN12V0	Buck	IC27	1.2V to 3.3V; +-5%	1.8A	FPGA, Zmod Port B
VADJC	VIN12V0	Buck	IC25	2.5 to 5.5V; +-5%	0.3A	FPGA Fan

The power budget of VCC5V0 is shared by the SYZYGY™ ports, USB OTG VBUS, RGB LEDs, and Case Fan. As such, the actual maximum current achievable by each peripheral varies with the Eclipse Z7's system configuration. Under worst-case conditions, VCC5V0 is capable of outputting a minimum of 3A of continuous current. In this scenario, 1A is budgeted for each Zmod

The Platform MCU (PMCU) enumerates the SYZYGY™ ports and determines the power needs of each Zmod installed in the system. The 5V power budget of the Eclipse is then determined based on the needs of each Zmod, as well as the USB OTG VBUS, RGB LEDs, and Fan. Table 1.2.2 describes the 5V power budget of the Eclipse Z7 in more detail.

Table 1.2.2: Eclipse 5V Power Budget

Device or Connector	Max Current (mA)
RGB LEDs	124.8
USB OTG VBUS	500
Zmod Port A	1000
Zmod Port B	1000

Device or Connector	Max Current (mA)
Case Fan	250

The two SYZYGY™ ports share a budget of 2A from the 3.3V supply. The two Pmod ports share a budget of 0.5A, which is allocated to the SYZYGY™ ports if no Pmods are installed.

Due to the requirements of the custom power sequencer (IC29), Digilent recommends that peripheral modules (Pmods and Zmods) attached to and powered by the Eclipse meet the specifications described in Table 1.2.3.

Table 1.2.3: Recommended Maximum Additional Capacitance for Add-on Modules

Port	Rail	Max Capacitance (μF)
Zmod Port A	VCC5V0	500
Zmod Port A	VCC3V3	500
Zmod Port A	VIO	1000
Zmod Port B	VCC5V0	500
Zmod Port B	VCC3V3	500
Zmod Port B	VIO	1000
Pmod Port A	VCC3V3	500
Pmod Port B	VCC3V3	500

1.3. Power Sequencing

A custom power sequencer (IC29) is used to sequence the power supplies on in the correct order when the power switch is placed in the “ON” position. The power supplies shut down in the opposite order when the power switch is moved to the “OFF” position. The startup sequence is as follows:

1. VCC5V0, FAN5V0
2. VCC1V0
3. VCC1V8
4. DDR1V35, DDRVTT
5. VCC3V3
6. VCC4V3
7. VADJA, VADJB, VADJC

The sequencer is provided 3.3V power by a dedicated regulator, a Texas Instruments LP2985 (IC28).

The sequencer ensures that the supply rails follow the Xilinx-recommended start-up and shut-down sequences.

Note: *VADJA, VADJB, and VADJC are controlled by the Platform MCU (PMCU) and may or may not be enabled, depending on the PMCU configuration and presence (or lack thereof) of any pods connected to Zmod A or Zmod B. If the sum of the currents required by each Zmod is in excess of the 3A budget for VCC5V0, VADJA and VADJB are not turned on.*

1.4. FPGA Fan

The FPGA fan is to be connected to the Eclipse Z7 via fan header J8 (labeled “FPGA”) and is powered by VADJC, an adjustable rail controlled by the Platform MCU. The FPGA fan's speed can be configured to Automatic (the default factory setting), High, Medium, Low, or Off, by communicating with the PMCU through its I2C interface. This configuration is preserved by the PMCU in an EEPROM() when the Eclipse's power is cycled. Additional information and configuration settings, including RPM and speed controls, can be accessed through the PMCU's I2C interface.

1.5. Case Fan

In addition to the FPGA fan, the Eclipse Z7 can power a Case Fan, connected to the board via fan header J14 (labeled “CASE”). This fan is powered by the 5V rail, and is limited to 250 mA. A compatible fan is included in the  Eclipse Z7 Enclosure Kit (<https://digilent.com/shop/eclipse-z7-enclosure-kit/>).

1.6. Platform MCU

As noted in previous sections, the Eclipse Z7 uses an Atmega328PB microcontroller (IC10), referred to as the Platform MCU (PMCU), to implement the SmartVIO requirements of the SYZYGY™ standard, as well as to monitor the Zynq die temperature, and to control the Eclipse's fan.

When the Eclipse is turned on, the PMCU enumerates the pods attached to the Eclipse's SYZYGY™ ports and retrieves their DNA, in order to correctly configure the variable supplies.

After SYZYGY™ enumeration is complete, the PMCU configures itself as an I2C slave device with a chip address of 0x60. Control of the I2C bus is then handed over to the Zynq's I2C 1 peripheral (MIO[12:13]). The Digilent Eclipse Utility (decutil) is included in Petalinux images for the Eclipse Z7 and can be used to get status information from and change some settings of the PMCU. For more information on the PMCU's register space and communication protocol, see the PMCU specification ( PDF Download (<https://digilent.s3-us-west-2.amazonaws.com/resources/programmable-logic/eclipse/Eclipse-PMCU-Specification-Public.pdf>)). For more information on decutil, see the Digilent Eclipse Utility Documentation (https://digilent.com/reference/_media/reference/programmable-logic/eclipse-z7/decutil.1.pdf).

The following tables describe the features of the Platform MCU supported by the Eclipse Z7:

Table 1.6.1: Platform MCU Connectivity Map

PMCU Interface	Connection
TEMPERATURE A	Zynq Die Temperature

PMCU Interface	Connection
PORT_A, VADJ_A	Zmod A
PORT_B, VADJ_B	Zmod B
FAN_1	FPGA Fan
FAN_2	Case Fan

Table 1.6.2: Supported Platform MCU Optional Features

Optional Features	Supported
DDRVCCSEL Control	No
INIT_B Control	No
USB Hub Support	No

Table 1.6.3: Supported Platform MCU Fan Control Features

Feature	FAN_1 (FPGA Fan)	FAN_2 (Case Fan)
Enable / Disable	Yes	No
Fixed Speed Control	Yes	No
Automatic Speed Control	Yes	No
RPM Measurement	Yes (if supported by installed fan) ¹⁾	Yes (if supported by installed fan) ²⁾

¹⁾ The optional FPGA fan included with the Eclipse Z7 supports RPM measurement

²⁾ The case fan included in the Eclipse Z7 Enclosure Kit does not support RPM measurement

2. Zynq Configuration

Unlike Xilinx FPGA devices, AP SoC devices such as the Zynq-7020 are designed around the processor, which acts as a master to the programmable logic fabric and all other on-chip peripherals in the processing system. This causes the Zynq boot process to be more similar to that of a microcontroller than an FPGA. This process involves the processor loading and executing a Zynq Boot Image, which includes a First Stage Bootloader (FSBL), a bitstream for configuring the programmable logic (optional), and a user application.

The boot process is broken into three stages:

Stage 0

After the Eclipse Z7 is powered on or the Zynq is reset (in software or by pressing the PS-SRST button, BTNR), one of the processors (CPU0) begins executing an internal piece of read-only code called the BootROM. If and only if the Zynq was just powered on, the BootROM will first latch the state of the mode pins into the mode register (the mode pins are attached to JP5 on the Eclipse Z7). If the BootROM is being executed due to a reset event, then the mode pins are not latched, and the previous state of the mode register is used. This means that the Eclipse Z7 needs a power cycle to register any change in the programming mode jumper (JP5). Next, the BootROM copies an FSBL from the form of non-volatile memory specified by the mode register to the 256 KB of internal RAM() within the APU (called On-Chip Memory, or OCM). The FSBL must be wrapped up in a Zynq Boot Image in order for the BootROM to properly copy it. The last thing the BootROM does is hand off execution to the FSBL in OCM.

Stage 1

During this stage, the FSBL first finishes configuring the PS components, such as the DDR memory controller. Then, if a bitstream is present in the Zynq Boot Image, it is read and used to configure the PL. Finally, the user application is loaded into memory from the Zynq Boot Image, and execution is handed off to it.

Stage 2

The last stage is the execution of the user application that was loaded by the FSBL. This can be any sort of program, from a simple bare-metal “Hello World” application, to a Second Stage Boot loader used to boot an operating system like Linux. For a more thorough explanation of the boot process, refer to Chapter 6 of the  Zynq Technical Reference Manual (<https://docs.xilinx.com/v/u/en-US/ug585-Zynq-7000-TRM>).

The Zynq Boot Image is created using Vivado and Xilinx Software Development Kit (Xilinx SDK). For information on creating this image please refer to the available Xilinx documentation for these tools.

The Eclipse Z7 supports three different boot modes: microSD, Quad SPI Flash, and JTAG. The boot mode is selected using the Mode jumper (JP5), which affects the state of the Zynq configuration pins after power-on. Figure 2.1 depicts how the Zynq configuration pins are connected on the Eclipse Z7.

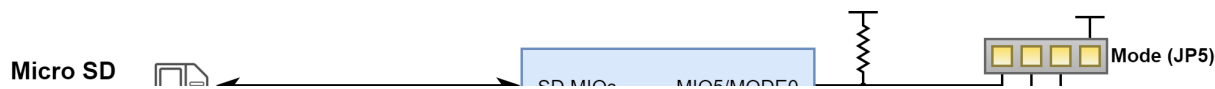

(https://digilent.com/reference/_detail/reference/programmable-logic/eclipse-z7/reference-manual/eclipse-config.png?id=programmable-logic%3Aeclipse-z7%3Areference-manual)

Figure 2.1: Eclipse Z7 configuration pins.

The three boot modes are described in the following sections.

2.1. microSD Boot Mode

The Eclipse Z7 supports booting from a microSD card inserted into connector J4 (labeled “SD CARD”). The following procedure will allow you to boot the Zynq from microSD with a standard Zynq Boot Image created with the Xilinx tools:

1. Format the microSD card with a FAT32 file system.
2. Copy the Zynq Boot Image created with Xilinx SDK to the microSD card.
3. Rename the Zynq Boot Image on the microSD card to BOOT.bin.
4. Eject the microSD card from your computer and insert it into J4 on the Eclipse Z7.
5. Attach a power supply to the Eclipse Z7 via the barrel jack (J11).
6. Place a single jumper on JP5, shorting the two rightmost pins (labeled “SD”).
7. Turn the board on by flipping the power switch to the ON position. The board will now boot the image on the microSD card.

2.2. Quad SPI Boot Mode

The Eclipse Z7 has an onboard 16 MB (Q) Quad-SPI Flash that the Zynq can boot from. Documentation available from Xilinx describes how to use Xilinx SDK to program a Zynq Boot Image into a Flash device attached to the Zynq. Once the Quad SPI Flash has been loaded with a Zynq Boot Image, the following steps can be followed to boot from it:

1. Attach a power supply to the Eclipse Z7 via the barrel jack (J11).
2. Place a single jumper on JP5, shorting the two center pins (labeled “QSPI”).
3. Turn the board on by flipping the power switch to the ON position. The board will now boot the image stored in the Quad SPI flash.

2.3. JTAG Boot Mode

When placed in JTAG boot mode, with the two leftmost pins of JP5 shorted (labeled “JTAG”), the processor will wait until software is loaded by a host computer using the Xilinx tools. After software has been loaded, it is possible to either let the software begin executing, or step through it line by line using Xilinx SDK.

It is also possible to directly configure the PL over JTAG, independent of the processor. This can be done using the Vivado Hardware Server.

The Eclipse Z7 is configured to boot in Cascaded JTAG mode, which allows the PS to be accessed via the same JTAG port as the PL. It is also possible to boot the Eclipse Z7 in Independent JTAG mode by shorting unloaded jumper JP3. This will cause the PS to not be accessible from the onboard JTAG circuitry, and only the PL will be visible in the scan chain. To access the PS over JTAG while in independent JTAG mode, users will have to route the signals for the PJTAG peripheral over EMIO, and use an external device to communicate with it.

3. DDR3L Memory

The Eclipse Z7 includes two ISSI IS43TR16256A(L)-125KBL DDR3L memory components, creating a single rank, 32-bit wide interface and a total of 1 GiB (Gibi-byte, or 1,073,741,824 bytes) of capacity. The DDR3L is connected to the hard memory controller in the Processor Subsystem (PS), as outlined in the Zynq documentation.

Note: *Please select Micron MT41K256M16 RE-125 as the Memory Part for the Vivado DDR Configuration.*

The PS incorporates an AXI memory port interface, a DDR controller, the associated PHY, and a dedicated I/O bank. DDR3L memory interface speeds up to 533 MHz/1066 MT/s are supported.

The Eclipse Z7 was routed with 40-ohm (+/-10%) trace impedance for single-ended signals, and differential clock and strobes set to 80 ohms (+/-10%). A feature called DCI (Digitally Controlled Impedance) is used to match the drive strength and termination impedance of the PS pins to the trace impedance. On the memory side, each chip calibrates its on-die termination and drive strength using a 240-ohm resistor on the ZQ pin.

Both the memory chips and the PS DDR bank are powered from the 1.35V supply. The mid-point reference of 0.675V is created with a simple resistor divider and is available to the Zynq as an external reference.

For proper operation, it is essential that the PS memory controller is configured properly. Settings range from the actual memory flavor to the board trace delays. For your convenience, the Eclipse Z7 Vivado board files are available on the [Eclipse Z7 Resource Center \(https://digilent.com/reference/programmable-logic/eclipse-z7/start\)](https://digilent.com/reference/programmable-logic/eclipse-z7/start) and automatically configure the Zynq Processing System IP core with the correct parameters.

For best DDR3L performance, DRAM training is enabled for write leveling, read gate, and read data eye options in the PS Configuration Tool in Xilinx tools. Training is done dynamically by the controller to account for board delays, process variations, and thermal drift. Optimum starting values for the training process are the board delays (propagation delays) for certain memory signals.

Board delays are specified for each of the byte groups. These parameters are board-specific and were calculated from the PCB trace length reports. The DQS to CLK Delay and Board Delay values are calculated specifically for the Eclipse Z7 memory interface PCB design.

For more details on memory controller operation, refer to the Xilinx  Zynq Technical Reference manual (<https://docs.xilinx.com/v/u/en-US/ug585-Zynq-7000-TRM>).

4. Quad-SPI Flash

The Eclipse Z7 features a Spansion S25FL128S 4-bit Quad-SPI serial NOR flash. The key device attributes are:

- Part number S25FL128S
- 16 MB of memory
- 1-bit, 2-bit, and 4-bit bus widths supported
- General use clock speeds up to 100 MHz, translating to 400 Mbps in Quad-SPI mode
- Zynq configuration clock speeds up to 94 MHz
- Powered from 3.3V

The Flash memory is used to provide non-volatile code and data storage. It can be used to initialize the PS and PL of the Zynq device with a Zynq Boot Image (also known as BOOT.BIN) generated using Xilinx tools such as Petalinux or Xilinx SDK. For information on booting the Eclipse Z7 with a Zynq Boot image, see section “2.2 Quad SPI Boot Mode”.

The Flash is also commonly used to store non-configuration data needed by the application. If doing this from a bare-metal application, The flash memory can be freely accessed using standalone libraries included with a Xilinx SDK BSP project. If doing this from a Petalinux generated embedded Linux system, the Flash can be partitioned as desired and mounted/accessed like a standard MTD block device. See the Petalinux and Xilinx SDK documentation for more information.

The Flash connects to the Quad-SPI Flash controller of the Zynq-7000 PS via pins in MIO Bank 0/500 (specifically MIO[1:6,8]), as outlined in the Zynq Technical Reference Manual. Quad-SPI feedback mode is used, thus `qspi_sclk_fb_out/MIO[8]` is left to freely toggle and is connected only to a 20K pull-up resistor to 3.3V. This allows a Quad-SPI clock frequency greater than FQSPICLK2. The details of these connections do not need to be known when using the Eclipse Z7's Vivado board files, as they will automatically configure your project to work correctly with the on-board Flash.

A globally unique MAC address is programmed into the One-Time-Programmable (OTP) region of the Flash on each Eclipse Z7 at the factory. For more information on this, see section [11. Ethernet](#). The MAC address can also be found on a sticker attached to the board.

The OTP region also includes a factory-programmed read-only 128-bit random number, intended to be used as a unique identifier for the flash part, which can be checked to determine whether the IC has been replaced. Digilent software does not make use of this random number. The very lowest address range [0x00;0x0F] can be read to access the random number. See the Spansion S25FL128S datasheet for information on this random number and accessing the OTP region.

5. Oscillators/Clocks

The Eclipse Z7 provides a 33.3333 MHz clock to the Zynq PS_CLK input, which is used to generate the clocks for each of the PS subsystems. The 33.3333 MHz () input allows the processor to operate at a maximum frequency of 667 MHz and the DDR3 memory controller to operate at a maximum clock rate of 533 MHz () (1066 MT/s). The Eclipse Z7 board files, available on the [Eclipse Z7 Resource Center](https://digilent.com/reference/programmable-logic/eclipse-z7/start) (<https://digilent.com/reference/programmable-logic/eclipse-z7/start>), will automatically configure the Zynq processing system IP core in Vivado to work with all PS attached devices, including the 33.3333 MHz () input oscillator.

The PS has a dedicated PLL capable of generating up to four reference clocks, each with settable frequencies, that can be used to clock custom logic implemented in the PL. Additionally, The Eclipse Z7 provides an external 125 MHz () reference clock directly to pin D18 of the PL. The external reference clock allows the PL to be used completely independently of the PS, which can be useful for simple applications that do not require the processor.

The PL of the Zynq-Z7020 also includes four MMCM's and four PLL's that can be used to generate clocks with precise frequencies and phase relationships. Any of the four PS reference clocks or the 125 MHz () external reference clock can be used as an input to the MMCMs and PLLs. For a full description of the capabilities of the Zynq PL clocking resources, refer to the [7 Series FPGAs Clocking Resources User Guide](https://docs.xilinx.com/v/u/en-US/ug472_7Series_Clocking) (https://docs.xilinx.com/v/u/en-US/ug472_7Series_Clocking) available from Xilinx.

Xilinx offers the Clocking Wizard IP core to assist in integrating the MMCM's and PLL's into a design. This wizard will properly instantiate the needed MMCMs and PLLs based on the desired frequencies and phase relationships specified by the user. The wizard will then output an easy-to-use wrapper component around these clocking resources that can be inserted into the user's design. The clocking wizard can be accessed from within the Vivado and IP Integrator tools.

Figure 5.1 outlines the clocking scheme used on the Eclipse Z7. Note that the reference clock output from the Ethernet PHY is used as the 125 MHz () reference clock to the PL, in order to cut the cost of including a dedicated oscillator for this purpose. Keep in mind that CLK125 will be disabled when the Ethernet PHY is held in hardware reset by driving the PHYRSTB signal low.

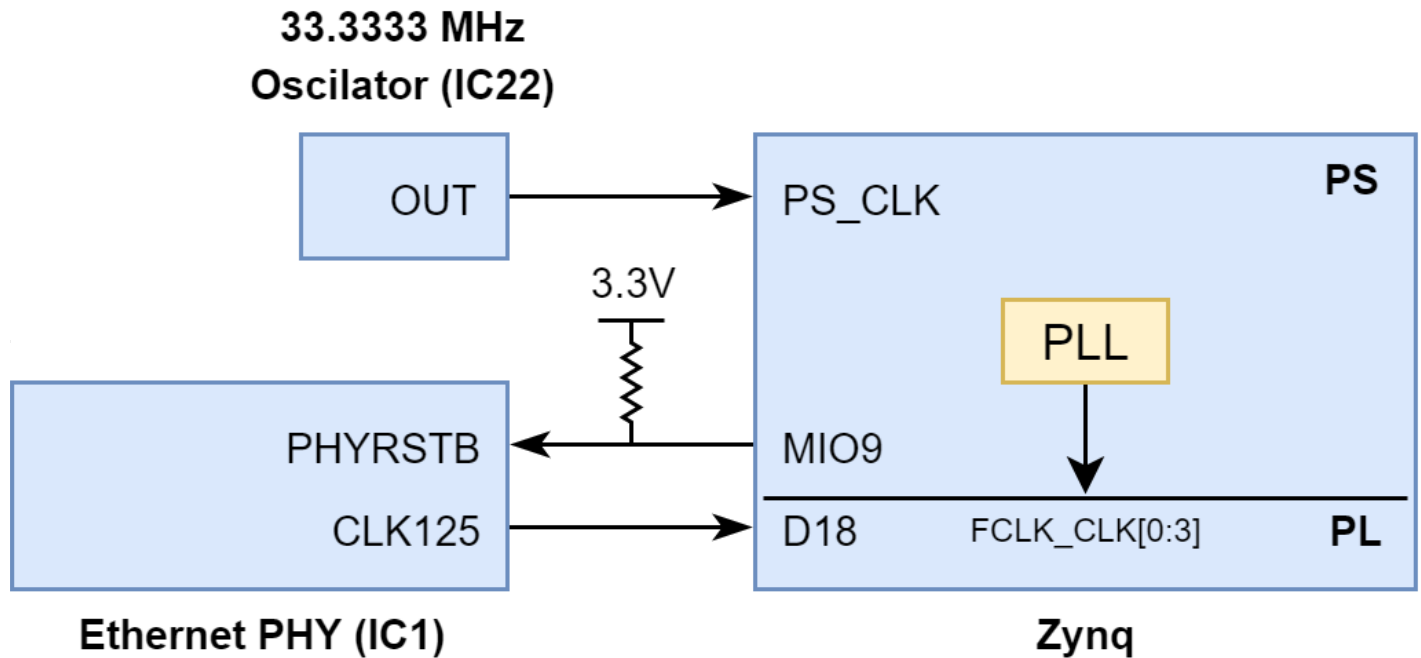

(https://digilent.com/reference/_detail/reference/programmable-logic/eclipse-z7/reference-manual/eclipse-clocks.png?id=programmable-logic%3Aeclipse-z7%3Areference-manual)

Figure 5.1: Eclipse Z7 clocking.

6. Reset Sources

The Eclipse Z7 provides several different methods of resetting the Zynq-7000 device, as described in the following sections:

6.1. Power-on Reset Signals

The Zynq PS supports external power-on reset signals. The power-on reset is the master reset of the entire chip. This signal resets every register in the device capable of being reset. The Eclipse Z7 drives this signal from the VCC4V3 supply, the final non-adjustable supply to be brought up in the power-on sequence, in order to hold the system in reset until all power supplies are valid. A push-button, labeled BTNP, can be used to toggle the power-on reset signal. BTNP is located on the underside of the Eclipse Z7, below the SD card slot.

6.2. Processor Subsystem Reset

The external system reset button, labeled BTNR, resets the Zynq device without disturbing the debug environment. For example, the previous break points set by the user remain valid after system reset. Due to security concerns, system reset erases all memory content within the PS, including the On-Chip-Memory (OCM). The PL is also cleared during a system reset. System reset does not cause the boot mode strapping pins to be re-sampled. After changing the boot mode jumper a power cycle is needed to act on the new setting. BTNR is located on the underside of the Eclipse Z7, below the SD card slot.

7. USB-UART Bridge (Serial Port)

The Eclipse Z7 includes an FTDI FT2232HQ USB-UART bridge (attached to connector J6) that lets PC applications communicate with the board using standard COM port commands (or the tty interface in Linux). Drivers are automatically installed in Windows and newer versions of Linux when the Eclipse Z7 is attached. Serial port data is exchanged with the Zynq using a two-wire serial port (TXD/RXD). After the drivers are installed, I/O commands can be used from the PC directed to the COM port to produce serial data traffic on the Zynq pins. The port is tied to PS (MIO) pins and can be used in combination with the UART 0 controller.

The Zynq presets file (available in the [Eclipse Z7 Resource Center](https://digilent.com/reference/programmable-logic/eclipse-z7/start) (<https://digilent.com/reference/programmable-logic/eclipse-z7/start>)) takes care of mapping the correct MIO pins to the UART 0 controller and uses the following default protocol parameters: 115200 baud rate, 1 stop bit, no parity, 8-bit character length.

Two status LEDs provide visual feedback on traffic flowing through the port: the transmit **LED** (the lower of the two yellow LEDs in the circuit board indicator, LD4) and the receive **LED** (the upper of the two yellow LEDs in the circuit board indicator, LD4). Signal names that imply direction are from the point-of-view of the DTE (Data Terminal Equipment), in this case the PC.

The FT2232HQ is also used as the controller for the Digilent USB-JTAG circuitry, but the USB-UART and USB-JTAG functions behave entirely independent of one another. Programmers interested in using the UART functionality of the FT2232 within their design do not need to worry about the JTAG circuitry interfering with the UART data transfers, and vice-versa. The combination of these two features into a single device allows the Zybo Z7 to be programmed and communicated with via UART from a computer attached with a single Micro USB cable.

The connections between the FT2232HQ and the Zynq-7000 are shown in Figure 7.1.

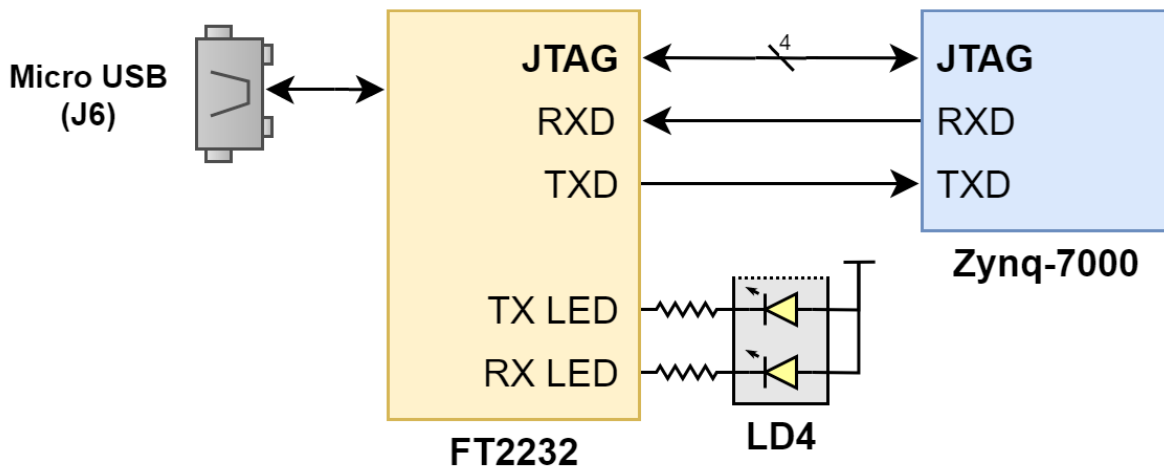

Figure 7.1: UART Connections

8. Zmod Ports

The Eclipse Z7 features two Zmod ports, which use SYZYGY™ Standard interfaces to communicate with installed SYZYGY™ pods. Both ports are compatible with version 1.1 of the SYZYGY™ specification from Opal Kelly.

SYZYGY™ SmartVIO functionality is implemented by the Eclipse's Platform MCU, as discussed in the [1 Power Supplies](#) section of this document. Each port's SYZYGY™ DNA is connected to both the Platform MCU and the Zynq's I2C 0 peripheral (MIO12:13) through a single I2C bus. Once the board is fully powered on, and the PMCU has configured itself in I2C slave mode, SYZYGY™ DNA data can be read directly from the pods, and the negotiated voltages and currents can be read from the PMCU over this bus.

Warning: *SYZYGY™ pods are NOT hot-swappable. Connecting or disconnecting a pod from the Eclipse while the board is powered on may cause damage to the pod and/or the board, and is to be avoided.*

Each SYZYGY™ Standard interface contains 16 single-ended I/O pins, 8 differential I/O pairs (which can alternatively be used as 16 additional single-ended I/O pins), and two dedicated differential clocks - one for input and one for output. Each Zmod port has a I/O bank of the Zynq dedicated to it, which is powered by a dedicated adjustable rail, configured by the Platform MCU as the Eclipse is powered on. Template constraints for each Zmod port can be found in the Eclipse Z7's Master XDC file, available through Digilent's [digilent-xdc](https://github.com/Digilent/digilent-xdc) repository on Github.

Digilent provides Eclipse-compatible low-level IPs, scripted Vivado flows, and software libraries to support each [Digilent Zmod](https://digilent.com/reference/zmod/start).

For more information on the SYZYGY™ standard, see syzygyfpga.io.

8.1. SYZYGY™ Pod Compatibility

The Eclipse's Zmod ports are compatible with a variety of different SYZYGY™ pods. Information required to determine if the Eclipse is compatible with a certain pod is summarized in Table 8.1.1.

Table 8.1.1: SYZYGY™ Compatibility Table

Parameter	Port A (STD)	Port B (STD)
Port Type	Standard	Standard
	Double-Width Capable	
Total 5V Supply Current	3.0 A (shared with USB VBUS output, Case Fan, and RGB LEDs)	
Total 3.3V Supply Current	2.0 A Shared	
VIO Supply Voltage Range	1.2V to 3.3V	1.2V to 3.3V
Total VIO Supply Current	1.8A (VIO Group 1)	1.8A (VIO Group 2)
Port Groups	Group 1: A	Group 2: B

Parameter	Port A (STD)	Port B (STD)
I/O Count	28 total (8 DP)	28 total (8 DP)
Length Matching	73.7 mm +/- 0.2 mm (including Zynq package delay)	

9. microSD Slot

The Eclipse Z7 provides a microSD slot (J4) for non-volatile external memory storage as well as booting the Zynq. The slot is wired to Bank 1/501 MIO[40-45], and also includes a card detect signal attached to MIO 47. On the PS side, peripheral SDIO 0 is mapped out to these pins and controls communication with the SD card. The pinout can be seen in Table 9.1. The peripheral controller supports 1-bit and 4-bit SD transfer modes, but does not support SPI mode. Based on the [Zynq Technical Reference Manual \(https://docs.xilinx.com/v/u/en-US/ug585-Zynq-7000-TRM\)](https://docs.xilinx.com/v/u/en-US/ug585-Zynq-7000-TRM), SDIO host mode is the only mode supported.

Table 9.1: microSD pinout

Signal Name	Description	Zynq Pin	SD Slot Pin
SD_D0	Data[0]	MIO42	7
SD_D1	Data[1]	MIO43	8
SD_D2	Data[2]	MIO44	1
SD_D3	Data[3]	MIO45	2
SD_CCLK	Clock	MIO40	5
SD_CMD	Command	MIO41	3
SD_CD	Card Detect	MIO47	9

The SD slot is powered from 3.3V, but is connected through MIO Bank 1/501 (1.8V). Therefore, a TI TXS02612 level shifter performs this translation. The TXS02612 is actually a 2-port SDIO port expander, but only its level shifter function is used. The connection diagram can be seen on Figure 9.1. Mapping out the correct pins and configuring the interface is handled by the Eclipse Z7 board files, available on the [Eclipse Z7 Resource Center \(https://digilent.com/reference/programmable-logic/eclipse-z7/start\)](https://digilent.com/reference/programmable-logic/eclipse-z7/start).

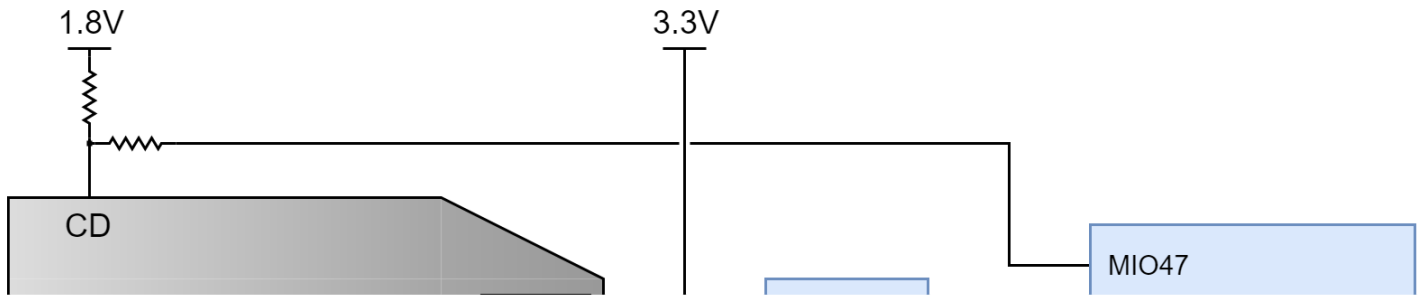

(https://digilent.com/reference/_detail/reference/programmable-logic/eclipse-z7/reference-manual/eclipse-micro-sd.png?id=programmable-logic%3Aeclipse-z7%3Areference-manual)

Figure 9.1: microSD slot signals

Both low speed and high speed cards are supported, the maximum clock frequency being 50 MHz. A Class 4 card or better is recommended.

Refer to section [2.1 microSD Boot Mode](#) for information on how to boot from a microSD card that contains a Zynq Boot Image.

The microSD is also commonly used to store non-configuration data needed by the application. If doing this from a bare-metal application, the microSD card can be freely accessed using standalone libraries included with a Xilinx SDK BSP project. If doing this from a Petalinux generated embedded Linux system, the microSD can be mounted/accessed like a standard block device, typically with a device node named `/dev/mmcblk0`. See the Petalinux and Xilinx SDK documentation for more information.

10. USB Micro-AB Device/Host/OTG Port

The Eclipse Z7 implements one of the two available PS USB OTG interfaces on the Zynq device. A Microchip USB3320 USB 2.0 Transceiver Chip with an 8-bit ULPI interface is used as the PHY. The PHY features a complete HS-USB Physical Front-End supporting speeds of up to 480Mbps. The PHY is connected to MIO Bank 1/501, which is powered at 1.8V. The `usb0` peripheral is used on the PS, connected through MIO[28-39]. The USB OTG interface can act as an host, embedded host, or a peripheral device, through the USB Micro AB connector(J5). The USB mode is controlled from software by manipulating the `USB0` peripheral controller in the Zynq PS.

By default, VBUS capacitance is 4.7 μ F. Jumper JP1 may be shorted while in host mode in order to increase VBUS capacitance by 150 μ F. Jumper JP2 must be installed for the Eclipse to power VBUS for host or embedded host applications. These requirements give three possible configurations for the two jumpers, as presented in Table 10.1.

Whether the Eclipse Z7 is configured as an embedded host or a general purpose host, it can provide at least 500 mA on the 5V VBUS line. More than 500 mA of current can potentially be provided depending on the system configuration and how much power is drawn by installed Zmods. See the [1 Power Supplies](#) section for more information.

Table 10.1: USB Mode Jumper Positions

Mode	JP1 Shorted	JP2 Shorted
Embedded Host	No	Yes
General Purpose Host	Yes	Yes
Peripheral Device	No	No

11. Ethernet

The Eclipse Z7 uses a Realtek RTL8211E-VL PHY to implement a 10/100/1000 Ethernet port for network connection. The PHY connects to MIO Bank 501 (1.8V) and interfaces to the Zynq-7000 AP SoC via RGMII for data and MDIO for management. The auxiliary interrupt (INTB) and reset (PHYRSTB) signals connect to PS pins to be accessed through the MIO [GPIO](#) peripheral via MIO48 and MIO9 respectively. The connection diagram can be seen on Figure 11.1.

After power-up the PHY starts with Auto Negotiation enabled, advertising 10/100/1000 link speeds and full duplex. If there is an Ethernet-capable partner connected, the PHY automatically establishes a link with it, even with the Zynq not configured.



https://digilent.com/reference/_detail/reference/programmable-logic/eclipse-z7/reference-manual/eclipse-ethernet.png?id=programmable-logic%3Aeclipse-z7%3Areference-manual

Figure 11.1: Ethernet PHY signals

Two status indicator LEDs are located on the RJ-45 connector (J3) that indicate traffic (J3/LD2, right side of connector) and valid link state (J3/LD1, left side of connector). Table 11.1 shows the default behavior.

Table 11.1: Ethernet status LEDs

Function	Designator	State	Description
LINK	J3/LD1	Steady on	Link 10/100/1000
		Blinking 0.4s ON, 2s OFF	Link, Energy Efficient Ethernet (EEE) mode

Function	Designator	State	Description
ACT	J3/LD2	Blinking	Transmitting or Receiving

The Zynq incorporates two independent Gigabit Ethernet Controllers. They implement a 10/100/1000 half/full duplex Ethernet MAC. Of these two, GEM 0 can be mapped to the MIO pins where the PHY interfaces. Since the MIO bank is powered from 1.8V, the RGMII interface uses 1.8V HSTL Class 1 drivers. For this I/O standard an external reference of 0.9V is provided in bank 501 (PS_MIO_VREF). Mapping out the correct pins and configuring the interface is handled by the Eclipse Z7 Vivado board files.

Although the default power-up configuration of the PHY might be enough in most applications, the MDIO bus is available for management. The RTL8211E-VL is assigned the 5-bit address 00001 on the MDIO bus. With simple register read and write commands, status information can be read out or configuration changed. The Realtek PHY follows industry-standard register map for basic configuration.

The RGMII specification calls for the receive (RXC) and transmit clock (TXC) to be delayed relative to the data signals (RXD[0:3], RXCTL and TXD[0:3], TXCTL). Xilinx PCB guidelines also require this delay to be added. The RTL8211E-VL is capable of inserting a 2ns delay on both the TXC and RXC so that board traces do not need to be made longer.

On an Ethernet network each node needs a unique MAC address. To this end, the one-time-programmable (OTP) region of the Quad-SPI flash has been programmed at the factory with a 48-bit globally unique EUI-48/64™ compatible identifier. The OTP address range [0x20;0x25] contains the identifier with the first byte in transmission byte order being at the lowest address. Refer to the [Flash memory datasheet \(https://www.cypress.com/file/448601/download\)](https://www.cypress.com/file/448601/download) for information on how to access the OTP regions. When using Petalinux, this is automatically handled in the U-boot boot-loader, and the Linux system is automatically configured to use this unique MAC address. The identifier is also printed on a sticker found on the top-side of the Eclipse Z7 right next to the mode jumper (JP5) and above the headphone output jack.

For getting started using the ethernet port in a bare-metal application, Xilinx provides a lwip TCP/IP stack that can be automatically generated in Xilinx SDK along with an echo server example. When using the Eclipse Z7 with a Petalinux generated embedded Linux system, the ethernet port will automatically appear as a network device typically named eth0. See the Petalinux and Xilinx SDK documentation for more information.

For more low-level information on using the Zynq-7000 Gigabit Ethernet MAC, refer to the Xilinx Zynq Technical Reference Manual.

12. Basic I/O

The Eclipse Z7 includes two push-buttons and two tri-color LEDs connected to the Zynq PL, as shown in Figure 12.1. These I/Os are connected to the Zynq via series resistors to prevent damage from inadvertent short circuits (a short circuit could occur if a pin assigned to a push-button was inadvertently defined as an output).

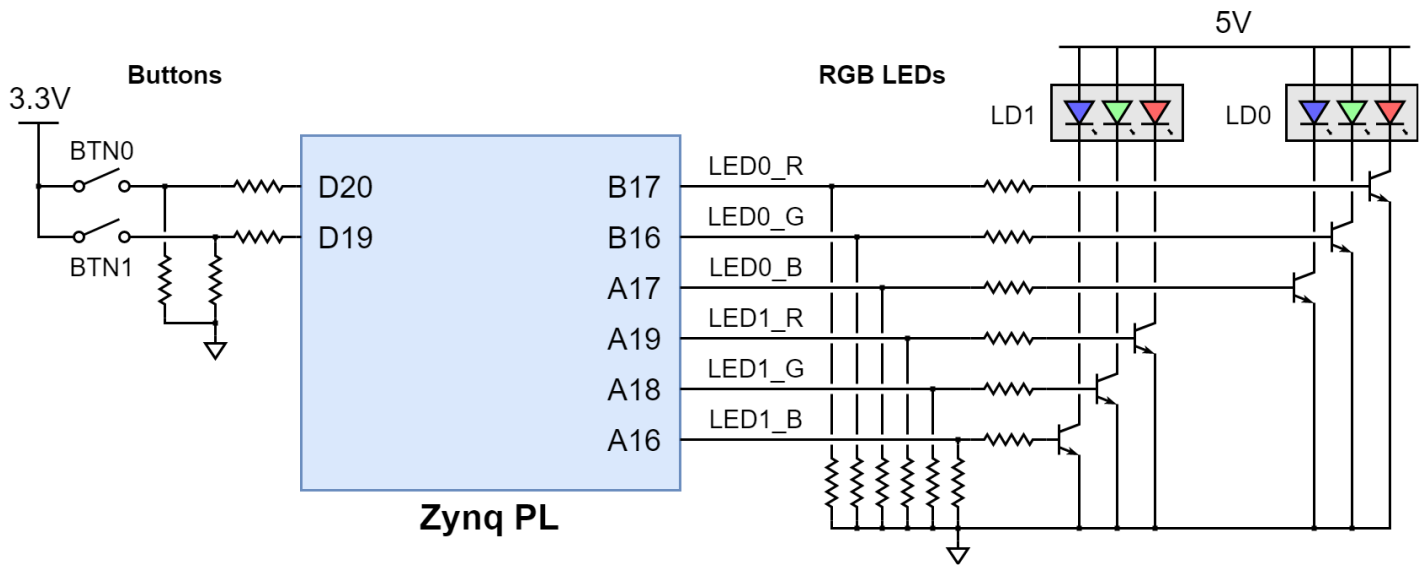

Figure 12.1: Eclipse Z7 Basic I/O

12.1. Push-Buttons

The push-buttons are “momentary” switches that normally generate a low output when they are at rest, and a high output only when they are pressed.

12.2. Tri-Color LEDs

Each tri-color `LED_0` has three input signals that drive the cathodes of three smaller internal LEDs: one red, one blue, and one green. Driving the input signal corresponding to one of these colors low will illuminate the internal `LED_0`. The input signals are driven by the Zynq PL through a transistor, which inverts the signals. Therefore, to light up the tri-color `LED_0`, the corresponding PL pins need to be driven high. The tri-color `LED_0` will emit a color dependent on the combination of internal LEDs that are currently being illuminated. For example, if the red and blue signals are driven high and green is driven low, the tri-color `LED_0` will emit a purple color.

Note: Digilent strongly recommends the use of pulse-width modulation (PWM) when driving the tri-color LEDs. Driving any of the signals to a steady logic '1' will result in the `LED_0` being illuminated at an uncomfortably bright level. This can be avoided by ensuring that none of the tri-color signals are driven with more than a 50% duty cycle. Using PWM also greatly expands the potential color palette of the tri-color `LED_0`. Individually adjusting the duty cycle of each color between 0% and 50% causes the different colors to be illuminated at different intensities, allowing virtually any color to be displayed.

13. Pmod Ports

Pmod ports are 2×6, right-angle, 100-mil spaced female connectors that mate with standard 2×6 pin headers. Each 12-pin Pmod port provides two 3.3V `VCC_0` signals (pins 6 and 12), two Ground signals (pins 5 and 11), and eight logic signals, as shown in Figure 13.1. The `VCC_0` and Ground pins can deliver up to 1A of current, but care must be taken not to exceed any of the power budgets of the on-board regulators or the external power supply (as described in the `Power supplies` section).

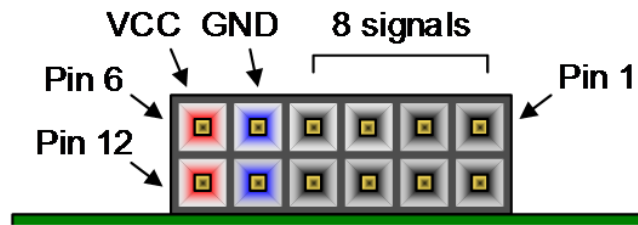

(https://digilent.com/reference/_detail/basys3-pmod_connector.png?id=programmable-logic%3Aeclipse-z7%3Areference-manual)

Figure 13.1: Pmod port

Digilent produces a large collection of Pmod accessory boards that can attach to the Pmod ports to add ready-made functions like A/D's, D/A's, motor drivers, sensors, and other functions. See www.digilentinc.com (<http://www.digilentinc.com>) for more information. The vivado-library repository on the [Digilent Github](https://github.com/Digilent/) (<https://github.com/Digilent/>) contains pre-made IP cores for many of these Pmods that greatly reduces the work of integrating them into your project. This repository's **hierarchies** branch contains additional scripts and sources that can be used to speed up the process of integrating these cores. See the Pmod-related tutorials on the Eclipse Z7 Resource Center for help using them.

The Eclipse Z7's two Pmod ports are connected to the Zynq PL via high-speed down translation and protection circuitry. When used as outputs, the Pmod pins are driven at 3.3V. When used as inputs, the Pmod pins are 5V tolerant. The maximum recommended voltage applied to these pins is 5.5V, though the inline resettable fuses will protect the FPGA pins from damage.

1)

The “SYZYGY™” mark is owned by Opal Kelly.

[Company \(https://digilent.com/company/\)](https://digilent.com/company/)

- [About Us \(https://digilent.com/company/#about-digilent\)](https://digilent.com/company/#about-digilent)
- [FAQs \(https://digilent.com/company/#faqs\)](https://digilent.com/company/#faqs)
- [Distributors \(https://digilent.com/shop/distributors/\)](https://digilent.com/shop/distributors/)
- [Shipping & Returns \(https://digilent.com/shipping-returns/\)](https://digilent.com/shipping-returns/)
- [Jobs \(https://digilent.com/company/#jobs\)](https://digilent.com/company/#jobs)
- [Legal & Privacy \(https://digilent.com/legal-privacy/\)](https://digilent.com/legal-privacy/)

[News \(https://digilent.com/news/\)](https://digilent.com/news/)

- [Blog \(https://digilent.com/blog/\)](https://digilent.com/blog/)
- [Newsletter \(https://digilent.com/news/#newsletter\)](https://digilent.com/news/#newsletter)
- [Events \(https://digilent.com/news/#events\)](https://digilent.com/news/#events)

Subscribe to our newsletter

Get the latest updates on new products and upcoming sales

Your email address

Submit

Contact Us

- [Technical Support Forum \(https://forum.digilent.com\)](https://forum.digilent.com)
- [Support Channels \(https://digilent.com/support/#channels\)](https://digilent.com/support/#channels)

Digilent

1300 NE Henley Ct. Suite 3

Pullman, WA 99163

United States of America

- [!\[\]\(e492b5d52ab457a7a3c2826c4091dfee_img.jpg\) \(http://twitter.com/DigilentInc\)](http://twitter.com/DigilentInc)
- [!\[\]\(1d9440fab1f214291ce1c26a75f9c2cd_img.jpg\) \(http://facebook.com/Digilent\)](http://facebook.com/Digilent)
- [!\[\]\(6be2e1cb461308cfbb51376f893366b1_img.jpg\) \(https://www.youtube.com/user/DigilentInc\)](https://www.youtube.com/user/DigilentInc)
- [!\[\]\(9d1c9e561b4c39f4d970a841cbc526df_img.jpg\) \(https://github.com/digilent\)](https://github.com/digilent)
- [!\[\]\(638c4e65afbf8f3994df6311f702c5cb_img.jpg\) \(https://instagram.com/digilentinc\)](https://instagram.com/digilentinc)
- [!\[\]\(ac8167fe1d77dc734374ed4531294f8f_img.jpg\) \(https://www.linkedin.com/company/1454013\)](https://www.linkedin.com/company/1454013)
- [!\[\]\(fff2f1ab464b6499fbd670c53975d01d_img.jpg\) \(https://www.flickr.com/photos/127815101@N07\)](https://www.flickr.com/photos/127815101@N07)