

UL US LISTED
File #E65324
NEMA 4, 4X

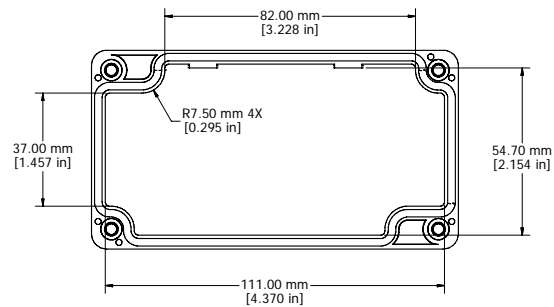
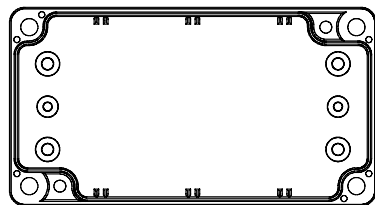
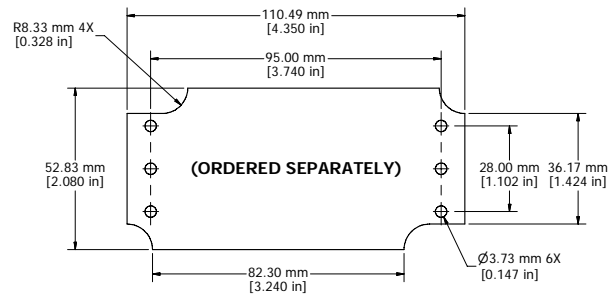
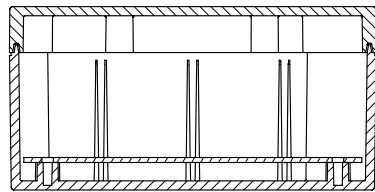
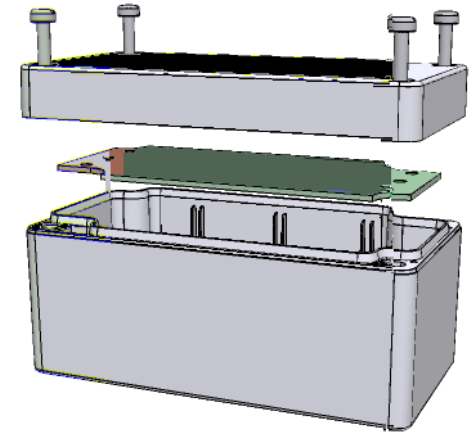

NOTE
Purchased assembly includes box, lid, and 4 cover screws
Recommended Cover screw torque -- 2.5 lbf-in (30 cN-m)
Polycarbonate version is UL 508 approved Matl UL94 - V0 / 5VA @ 3mm

1554D	
1554D Regular Enclosure	
General Purpose ABS RAL-7035	1554DGY
Polycarbonate RAL-7035	1554D2GY
1554D Clear / Smoke Lid Enclosure	
Polycarbonate Box / Clear Polycarbonate Lid	1554D2GYCL
Polycarbonate Box / Smoke Polycarbonate Lid	1554D2GYCL
ACCESSORIES	
Heavy Duty 16 Gauge Galvanized Steel Panels	1554DPL
Steel Panel / P.C. Board Machine Screw [M3 x 8mm Nickel Plated]	1591MM100
Steel Panel / P.C. Board Self Tapping Screw [#6 X 1/4" (6.4mm) Nickel Plated]	1598ATS100
Cover Screws (Pkg 4) [M4 X 20mm Type 304 Stainless Steel]	SC1554

HAMMOND MANUFACTURING™
1554D
www.hammondmfg.com