

KYW35A05 ... KYW35A6, KYW35K05 ... KYW35K6

**Silicon-Press-Fit-Diodes – High Temperature Diodes
Silizium-Einpress-Dioden – Hochtemperatur-Dioden**

Version 2006-04-22

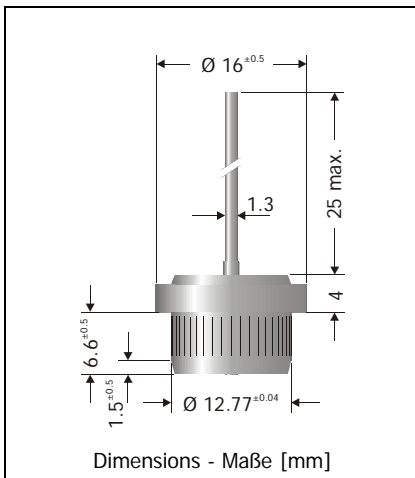

Nominal Current 35 A
 Nennstrom
 Repetitive peak reverse voltage 50 ... 600 V
 Periodische Spitzensperrspannung
 Metal press-fit case with glass seal
 Metall-Einpressgehäuse mit Glas-Durchführung
 Weight approx. 10 g
 Gewicht ca.
 Compound has classification UL94V-0
 Vergussmasse nach UL94V-0 klassifiziert
 Standard packaging: bulk
 Standard Lieferform: lose im Karton



Maximum ratings

Grenzwerte

Type / Typ Wire to / Draht an		Repetive peak reverse voltage Periodische Spitzensperrspannung V_{RRM} [V]	Surge peak reverse voltage Stoßspitzensperrspannung V_{RSM} [V]
Anode	Cathode		
KYW35A05	KYW35K05	50	60
KYW35A1	KYW35K1	100	120
KYW35A2	KYW35K2	200	240
KYW35A3	KYW35K3	300	360
KYW35A4	KYW35K4	400	480
KYW35A6	KYW35K6	600	700

Max. average forward rectified current, R-load Dauergrenzstrom in Einwegschaltung mit R-Last	$T_C = 100^\circ\text{C}$	I_{FAV}	35 A
Repetitive peak forward current Periodischer Spitzenstrom	$f > 15\text{ Hz}$	I_{FRM}	130 A ¹⁾
Peak forward surge current, 50/60 Hz half sine-wave Stoßstrom für eine 50/60 Hz Sinus-Halbwelle	$T_A = 25^\circ\text{C}$	I_{FSM}	360/400 A
Rating for fusing, $t < 10\text{ ms}$ Grenzlastintegral, $t < 10\text{ ms}$	$T_A = 25^\circ\text{C}$	i^2t	660 A ² s
Operating junction temperature – Sperrschichttemperatur Storage temperature – Lagerungstemperatur		T_j T_s	-50...+175°C -50...+175°C

1 Max. case temperature $T_C = 150^\circ\text{C}$ – Max. Gehäusetemperatur $T_C = 150^\circ\text{C}$

Characteristics

Kennwerte

Forward Voltage – Durchlass-Spannung	$T_j = 25^\circ\text{C}$ $I_F = 35\text{ A}$	V_F	< 1.1 V
Leakage Current – Sperrstrom	$T_j = 25^\circ\text{C}$ $V_R = V_{RRM}$	I_R	< 100 μA
Thermal Resistance Junction – Case Wärmewiderstand Sperrschicht – Gehäuse		R_{thc}	< 0.8 K/W

