

Proportional pressure reducing valve in 3-way version, pilot operated

Type 3DRE(M) and 3DRE(M)E

RE 29286

Edition: 2014-02

Replaces: 2010-01

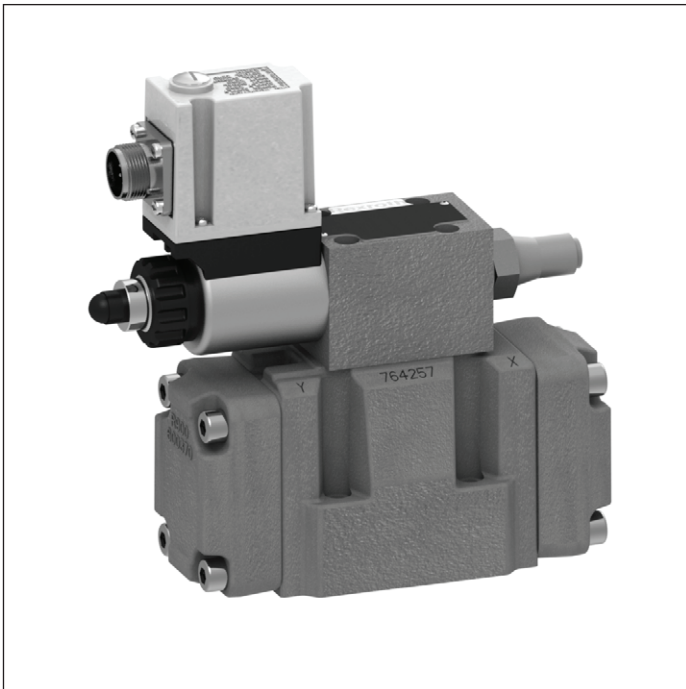

- ▶ Sizes 10 and 16
- ▶ Component series 7X
- ▶ Maximum set pressure: 315 bar (size 10)
250 bar (size 16)
- ▶ Flow: 125 l/min (size 10)
300 l/min (size 16)

Features

- ▶ Pilot operated valves for pressure reduction (P to A) and limitation (A to T) of a system pressure
- ▶ Operation by means of proportional solenoid with rotatable coil
- ▶ For subplate mounting:
Porting pattern according to DIN 24340-A and ISO 4401
- ▶ Maximum pressure limitation optional
- ▶ Valve and control electronics from a single source
- ▶ Integrated electronics (OBE) with type 3DRE(M)E:
Little manufacturing tolerance of the command value
pressure characteristic curve
- ▶ External control electronics with type 3DRE(M)
- ▶ Linear command value pressure characteristic curve

Contents

Features	1
Ordering code	2
Symbols	3
Function, section	4, 5
Technical data	6, 7
Electrical connection	8, 9
Integrated electronics (OBE)	9
Characteristic curves	10 ... 13
Dimensions	14, 15
Pilot oil supply	16
Accessories	17

Ordering code

01	02	03	04	05	06	07	08	09	10	11	12	13	14
3DRE				P	-	7X	/		G24				*

01	Proportional pressure reducing valve in 3-way version	3DRE
02	Without maximum pressure limitation	no code
	With maximum pressure limitation	M
03	For external control electronics	no code
	With integrated electronics (OBE)	E

Size

04	Size 10	10
	Size 16	16
05	Subplate mounting	P
06	Component series 70 to 79 (70 to 79: Unchanged installation and connection dimensions)	7X

Pressure rating

07	Up to 50 bar	50
	Up to 100 bar	100
	Up to 200 bar	200
	Up to 250 bar (only size 16)	250
	Up to 315 bar (only size 10)	315
08	Pilot oil supply internal, pilot oil return external	Y
	Pilot oil supply external, pilot oil return external	XY

Supply voltage

09	24 V DC voltage	G24
10	1600 mA coil	no code
	800 mA coil (only possible for external control electronics)	-8

Electrical connection

11	For type 3DRE(M):	
	Without mating connector; connector DIN EN 175301-803	K4
	For type DBE(M)E:	
	Without mating connector; connector DIN EN 175201-804	K31

Electronics interface

12	Command value 0 to 10 V	A1
	Command value 4 to 20 mA	F1
	With 3DRE for external control electronics	no code

Seal material

13	FKM seals	V
	NBR seals	M
14	Further details in the plain text	

Symbols

Pilot oil supply internal
Pilot oil return external

Pilot oil supply external
Pilot oil return external

Type 3DRE...Y...

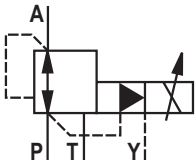

Type 3DREM...Y...

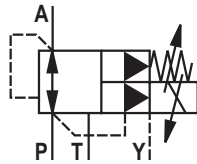

Type 3DRE...XY...

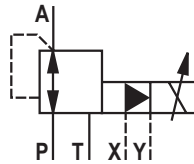

Type 3DREM...XY...

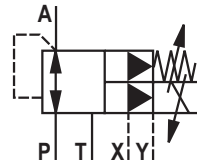

With integrated electronics:

Type 3DREE...Y...

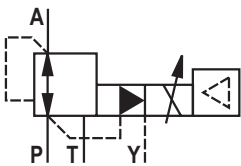

Type 3DREME...Y...

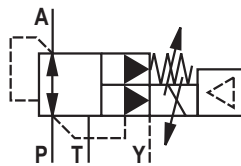

Type 3DREE...XY...

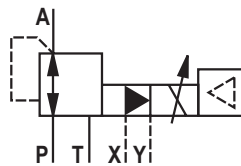

Type 3DREME...XY...

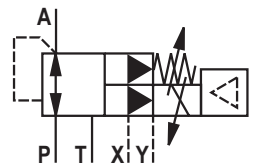

Function, section

The valve types 3DRE(M) and 3DRE(M)E are electrically pilot operated 3-way pressure reducing valves with pressure limitation of the actuator.

They are used for reducing a system pressure.

Technical set-up

The valve consists of two main assemblies:

- ▶ Pilot control valve (1) with proportional solenoid (2) optionally with maximum pressure limitation (15)
- ▶ Main valve (3) with main spool (4)

Function

General function:

- ▶ Command value-dependent setting of the pressure to be reduced in port A via the pilot control valve (1).
- ▶ With depressurized port P, the springs (5) and (6) hold the main spool (4) in its central position. In this way, a start-up jump at the actuator is prevented.
- ▶ Pilot oil flows from bore (7) via the flow controller (8), via the control chamber (11) to the throttle gap (9), via line (10) to port Y. This connection is to be led into the tank at zero pressure.

Pressure reduction:

- ▶ Build-up of the pilot pressure in the control chamber (11) as function of the command value.
- ▶ Pressure build-up in the spring chamber (13) via nozzle (12) and movement of the main spool (4) to the right, hydraulic fluid flows from P to A.

- ▶ The actuator pressure in port A is available in the spring chamber (14).
- ▶ Increase in the pressure in port A to the set pressure of the pilot control valve (1) leads to the movement of the main spool (4) to the left. The pressure in port A is almost equal to the pressure set at the pilot control valve (1).

Pressure limitation:

- ▶ If the pressure in port A exceeds the set pressure of the pilot control valve (1), the main spool (4) is moved further to the left.
- ▶ This opens the connection from A to T and limits the pressure pending in port A to the set command value.

Type 3DREM

For hydraulic protection against an inadmissibly high electric control current at the proportional solenoid, which imperatively results in increased pressures in port A, you can optionally install a spring-loaded pressure relief valve as maximum pressure limitation (15). This maximum pressure limitation is pre-set, referred to the relevant pressure rating (table page 6).

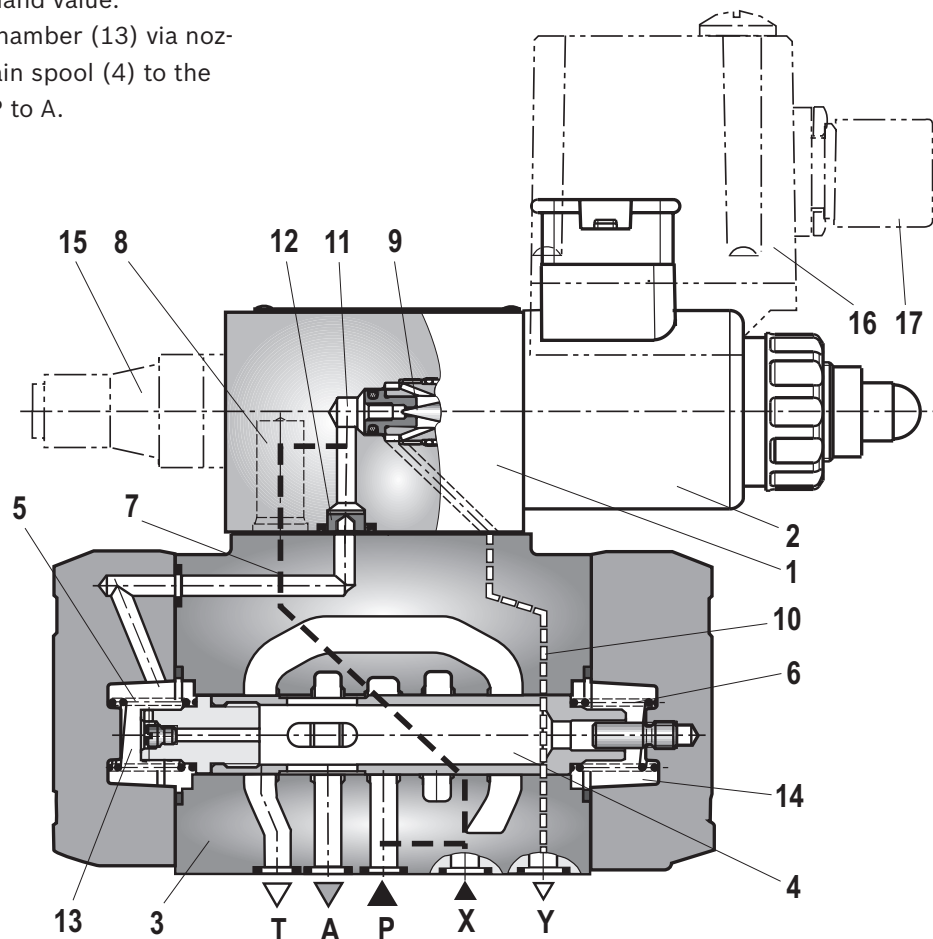

Function, section

Type 3DREE and 3DREME – with integrated electronics (OBE)

With regard to function and set-up, these valves correspond to types 3DRE and 3DREM. At the pilot control valve, there is moreover a housing (19) with the control electronics.

Supply and command value voltage are applied at the connector (20).

At the factory, the command value pressure characteristic curve is adjusted with little manufacturing tolerance.

For more information on the control electronics, see page 9.

Type 3DRE(M)E...-7X/...YG24K31

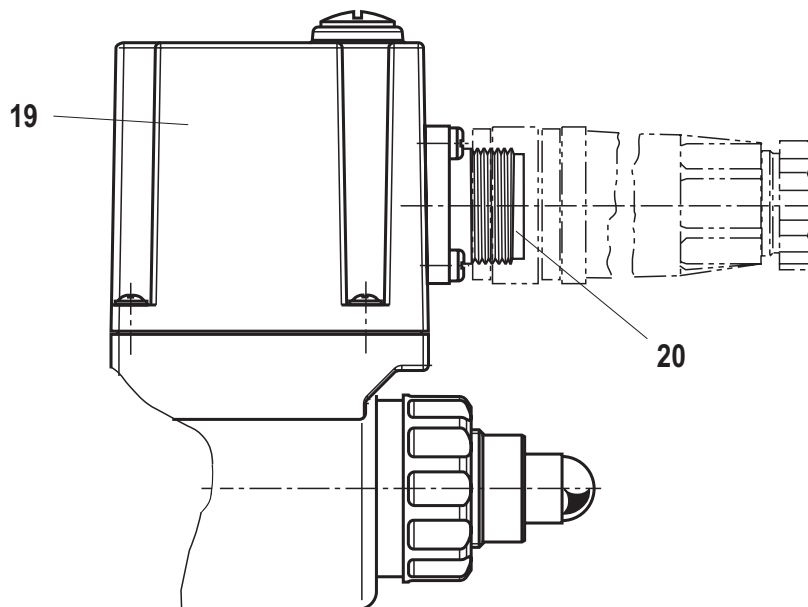

Technical data

(For applications outside these parameters, please consult us!)

general			Size 10	Size 16
Weight	- Type 3DRE and 3DREM	kg	7.5	10.3
	- Type 3DREE and 3DREME	kg	7.6	10.4
Installation position			Any, preferably horizontal	
Storage temperature range		°C	-20 to +80	
Ambient temperature range	- Type 3DRE and 3DREM	°C	-20 to +70	
	- Type 3DREE and 3DREME	°C	-20 to +50	

hydraulic (measured with HLP46, $\vartheta_{oil} = 40 \pm 5$ °C)			Size 10	Size 16
Maximum operating pressure	- Port P and X	bar	350	315
	- Port A and T	bar	315	250
	- Port Y	bar	Separately and to the tank at zero pressure	
Maximum set pressure in channel A	- Pressure rating 50 bar	bar	50	50
	- Pressure rating 100 bar	bar	100	100
	- Pressure rating 200 bar	bar	200	200
	- Pressure rating 250 bar	bar	-	250
	- Pressure rating 315 bar	bar	315	-
Minimum set pressure in channel A with flow, with command value zero, see characteristic curves page 8		bar	< 5	< 4
Maximum pressure limitation (continuously adjustable)	- Pressure rating 50 bar	bar	Set at the factory to 70 bar	
	- Pressure rating 100 bar	bar	Set at the factory to 130 bar	
	- Pressure rating 200 bar	bar	Set at the factory to 230 bar	
	- Pressure rating 250 bar (only size 16)	bar	Set at the factory to 270 bar	
	- Pressure rating 315 bar (only size 10)	bar	Set at the factory to 350 bar	
Maximum admissible flow		l/min	125	300
Pilot flow		l/min	1.1	
Hydraulic fluid			See table page 7	
Hydraulic fluid temperature range		°C	-20 to +80	
Viscosity range		mm ² /s	15 to 380	
Maximum admissible degree of contamination of the hydraulic fluid, cleanliness class according to ISO 4406 (c)			Class 20/18/15 ¹⁾	
Hysteresis		%	±3 of the maximum set pressure	
Repetition accuracy		%	< ±2 of the maximum set pressure	
Linearity		%	±3.5 of the maximum set pressure	
Manufacturing tolerance of the command value pressure characteristic curve, related to the hysteresis characteristic curve; pressure increasing	- Type 3DRE(M) ³⁾	at 20 % of the command value	% < ±1.5 of the maximum set pressure	
	- Type 3DRE(M) ³⁾	at 100 % of the command value	% < ±5 of the maximum set pressure	
	- Type 3DRE(M) ²⁾	at 100 % of the command value	% < ±1.5 of the maximum set pressure	
Step response $T_u + T_g$		Command value 10 % → 90 %	ms < 140; measured with standing hydraulic fluid column, 1.0 liters at port A	

¹⁾ The cleanliness classes specified for the components must be adhered to in hydraulic systems. Effective filtration prevents faults and at the same time increases the life cycle of the components.

For the selection of the filters see www.boschrexroth.com/filter.

²⁾ Adjustment at the factory.

³⁾ For details, see page 10.

Technical data

(For applications outside these parameters, please consult us!)

Hydraulic fluid	Classification	Suitable sealing materials	Standards
Mineral oils and related hydrocarbons	HL, HLP	NBR, FKM	DIN 51524
Bio-degradable – insoluble in water	HEES	FKM	VDMA 24568
Flame-resistant – water-free	HFDU	FKM	ISO 12922
– containing water	HFC	NBR	ISO 12922

 **Important information on hydraulic fluids!**

- ▶ For more information and data on the use of other hydraulic fluids refer to data sheet 90220 or contact us!
- ▶ There may be limitations regarding the technical valve data (temperature, pressure range, life cycle, maintenance intervals, etc.)!
- ▶ The flash point of the hydraulic fluid used must be 40 K higher than the maximum solenoid surface temperature.

▶ **Flame-resistant – containing water:** The maximum pressure differential per control edge is 210 bar. Otherwise, there is increased cavitation erosion. Life cycle as compared to HLP 30 % to 100 %
Fluid temperature maximum 60 °C

▶ **Bio-degradable:** When using bio-degradable hydraulic fluids that are zinc-soluble, zinc may accumulate in the fluid (700 mg zinc per pole tube).

electric		G24	G24-8
Minimum solenoid current	mA	≤ 100	≤ 100
Maximum solenoid current	mA	1600 ±10 %	800 ±5 %
Solenoid coil resistance	– Cold value at 20 °C	Ω	20.6
	– Maximum hot value	Ω	33
Duty cycle	%	100	100

electrical, integrated electronics (OBE)			
Supply voltage	– Nominal voltage	VDC	24
	– Lower limit value	VDC	21
	– Upper limit	VDC	35
Current consumption		A	≤ 1.5
Required fuse protection		A	2, time-lag
Inputs	– Voltage	V	0 to 10
	– Current	mA	4 to 20
Output	– Actual current value	mV	1 mV ± 1 mA
Protection class of the valve according to EN 60529			IP 65 with mating connector mounted and locked

Electrical connection

(dimensions in mm)

Type 3DRE(M)

Connection at the connector

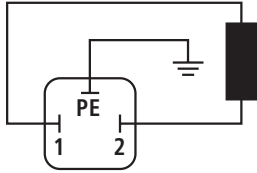

Connection at mating connector

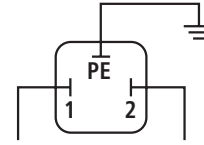

to the amplifier

Mating connector (black) according to DIN EN 175301-803, material no. **R901017011** (separate order)

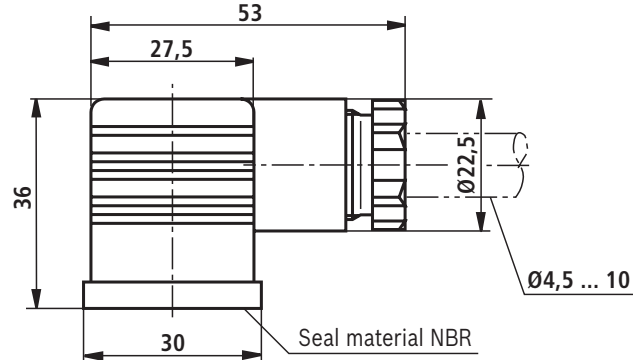
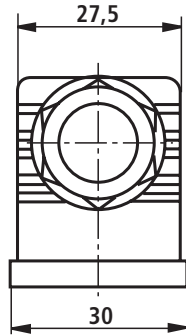

Type 3DRE(M)E

Connector pin assignment	Contact	Allocation interface "A1"	Allocation interface "F1"
Supply voltage	A	24 VDC (u(t) = 21 V to 35 V); $I_{max} \leq 1.5$ A	
	B	0 V	
Reference potential actual value	C	Reference contact F; 0 V	Reference contact F; 0 V
Differential amplifier input	D	0 to 10 V; $R_E = 100$ k Ω	4 to 20 mA; $R_E = 100$ Ω
	E	Reference potential command value	
Measuring output (actual value)	F	0 to 1.6 V actual value (1 mV \triangleq 1 mA) load resistance > 10 k Ω	
Protective earth	PE	Connected to solenoid and valve housing	

Mating connectors according to DIN EN 175201-804, solder contacts for line cross-section 0.5 to 1.5 mm²

Plastic version, material no. **R900021267** (separate order)

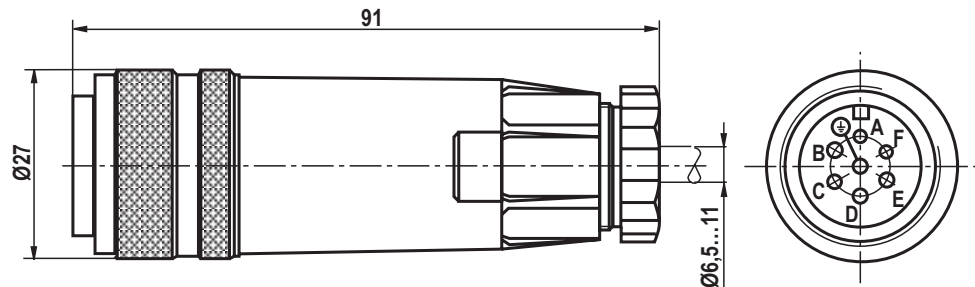

Metal version, material no. **R900223890** (separate order)

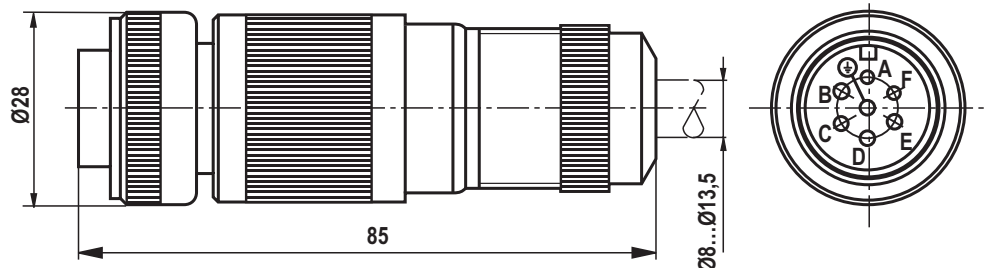

Electrical connection

Connection cable for type 3DRE(M)E

- Recommendation 6-wire, 0.75 or 1 mm² plus protective earthing conductor and screening
- Only connect the screening to PE on the supply side
- Maximum admissible length 100 m

The minimum supply voltage at the power supply unit depends on the length of the supply line (see diagram).

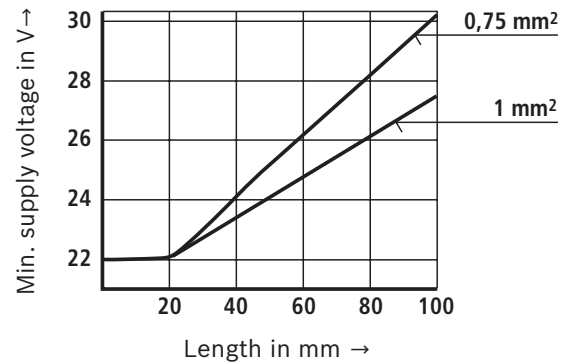

Integrated electronics (OBE) with type 3DRE(M)E

Function

The electronics are supplied with voltage via ports A and B. The command value is applied to the differential amplifier ports D and E.

Via the characteristic curve generator, the command value solenoid current characteristic curve is adjusted to the valve so that non-linearities in the hydraulics are compensated for and a linear command value pressure characteristic curve is created.

The current controller controls the solenoid current independently of the solenoid coil resistance.

The power stage of the electronics for controlling the proportional solenoid is a chopper amplifier with a cycle frequency of approx. 180 Hz to 400 Hz. The output signal is pulse-width modulated (PWM).

For checking the solenoid current, a voltage can be measured at the connector between pin F(+) and pin C(-) that is proportional to the solenoid current. **1 mV** corresponds to **1 mA** solenoid current.

Block diagram

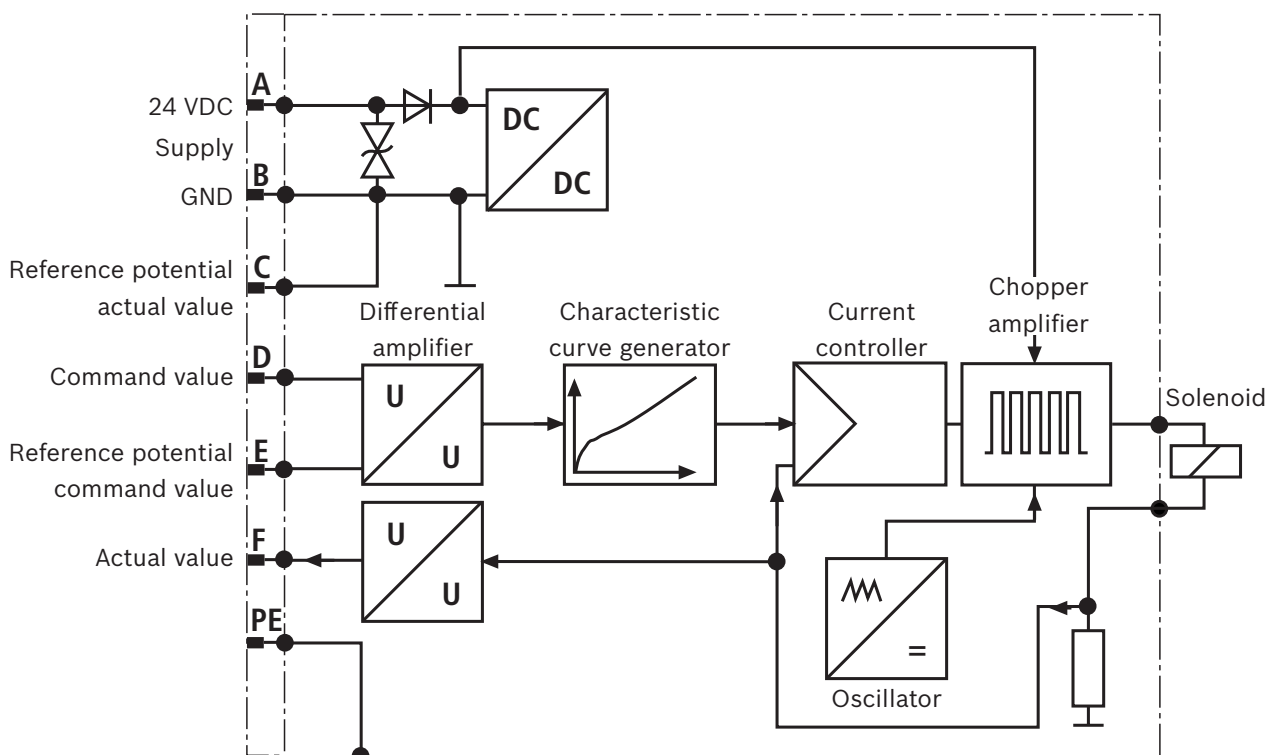

Characteristic curves

(measured with HLP46, $\vartheta_{oil} = 40 \pm 5 \text{ }^\circ\text{C}$, valve body and hydraulic fluid temperature-compensated. Large temperature differences may lead to differing characteristic curves/values.)

Pressure in port A depending on the command value (manufacturing tolerance)

without flow

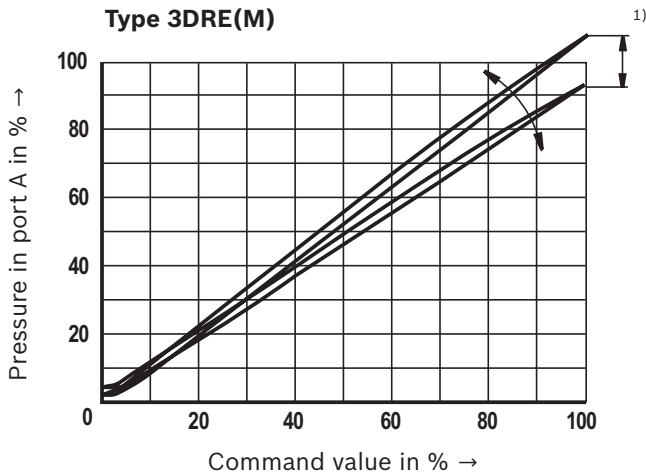

¹⁾ With valve type 3DRE(M), the manufacturing tolerance at the **external amplifier** (type and data sheet see page 16) can be changed using the command value attenuator potentiometer "Gw". The digital amplifier is set using the parameter "Limit".

In this context, the control current according to the technical data must not be exceeded.

In order to be able to adjust several valves to the same characteristic curve, do not set the pressure higher than the maximum set pressure of the pressure rating with command value 100 %.

Pressure in port P depending on the command value

Comparison G24 and G24-8 / pressure rating 200 bar (with amplifier VT-VSPA1-1-1X with 800 mA coil)

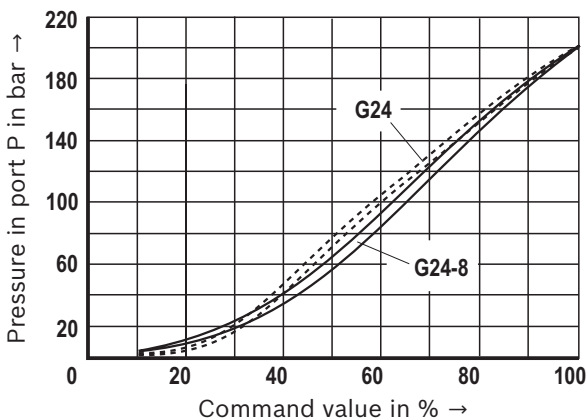

Current drop with version G24-8 with increasing ambient temperature, 24 V and 100 % duty cycle

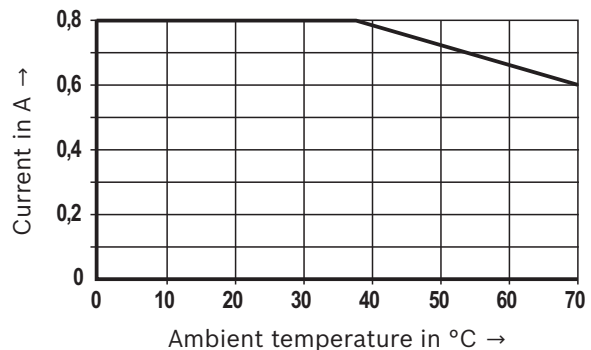

Notice!

With version G24-8, the solenoid current drops in case of increased temperature. Thus, the set pressure differs accordingly.

Characteristic curves

(measured with HLP46, $\vartheta_{oil} = 40 \pm 5 \text{ }^\circ\text{C}$, valve body and hydraulic fluid temperature-compensated. Large temperature differences may lead to differing characteristic curves/values.)

Pressure in port A depending on the command value (with flow 0 l/min)

Size 10, pressure rating 50 bar

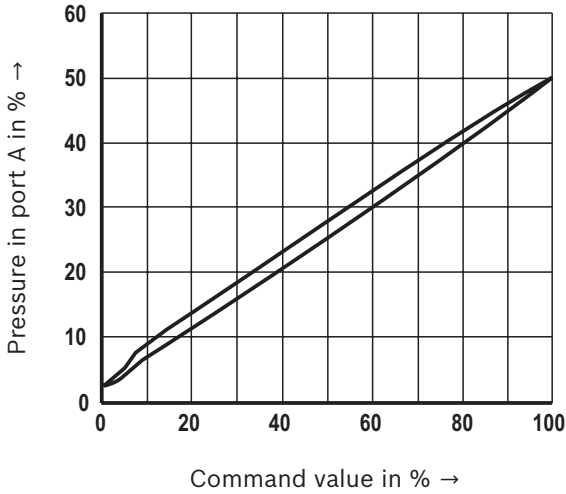

Size 10, pressure rating 100 bar

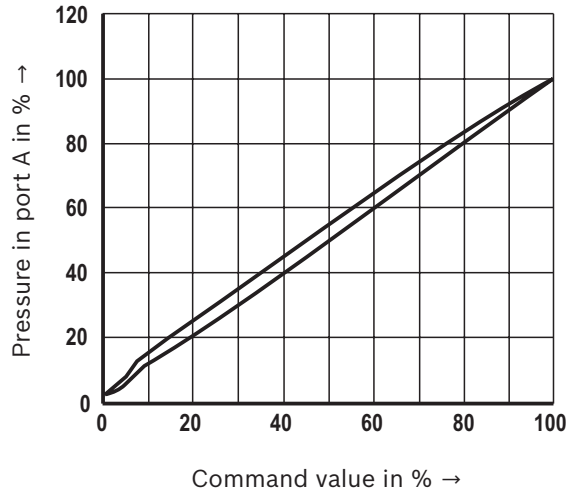

Size 10, pressure rating 200 bar

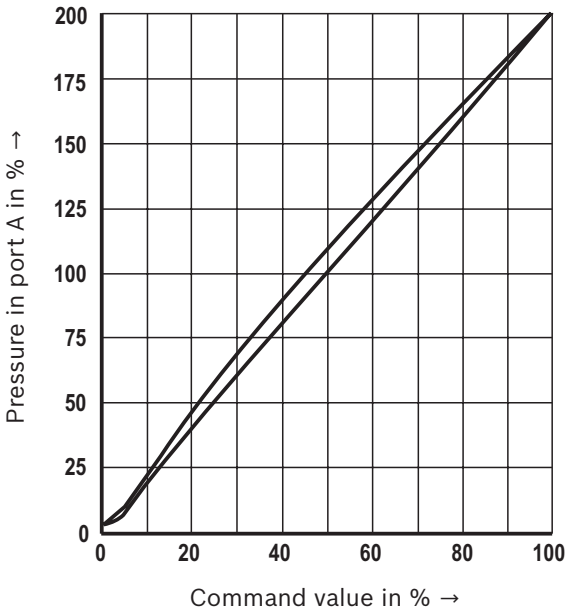

Size 10, pressure rating 315 bar

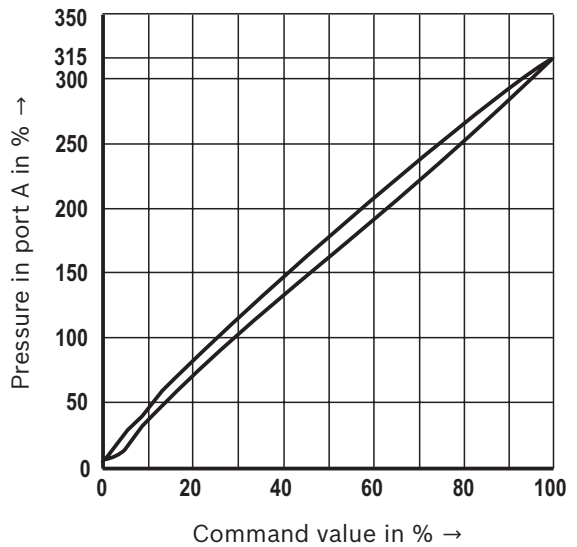

Characteristic curves

(measured with HLP46, $\vartheta_{oil} = 40 \pm 5 \text{ }^\circ\text{C}$, valve body and hydraulic fluid temperature-compensated. Large temperature differences may lead to differing characteristic curves/values.)

Pressure in port A depending on the command value (with flow 0 l/min)

Size 16, pressure rating 50 bar

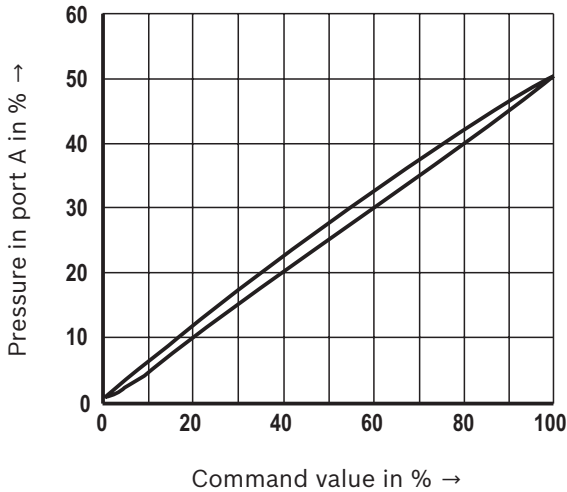

Size 16, pressure rating 100 bar

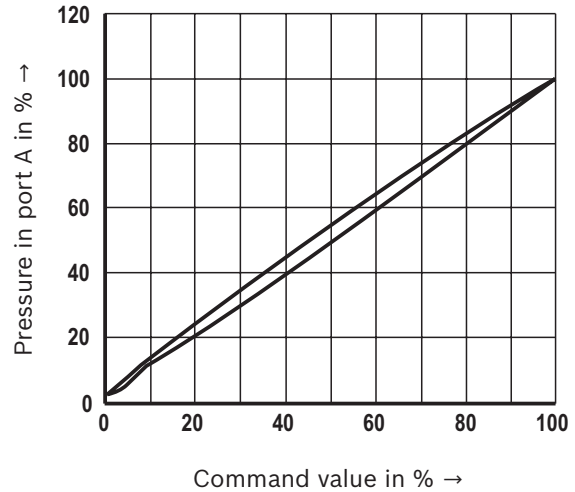

Size 16, pressure rating 200 bar

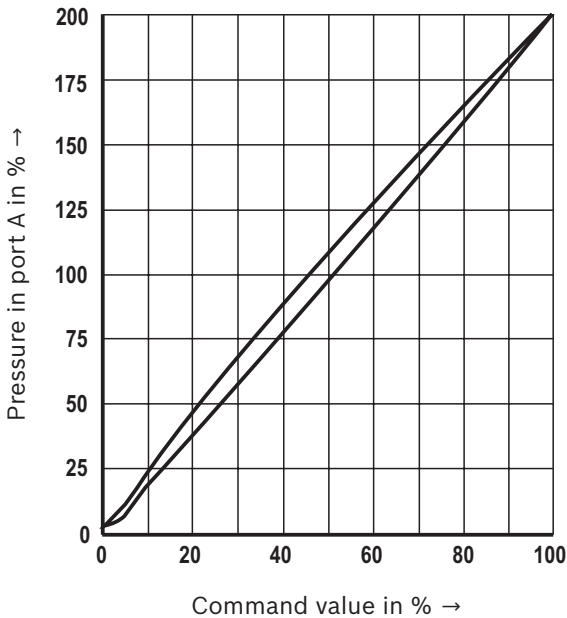

Size 16, pressure rating 250 bar

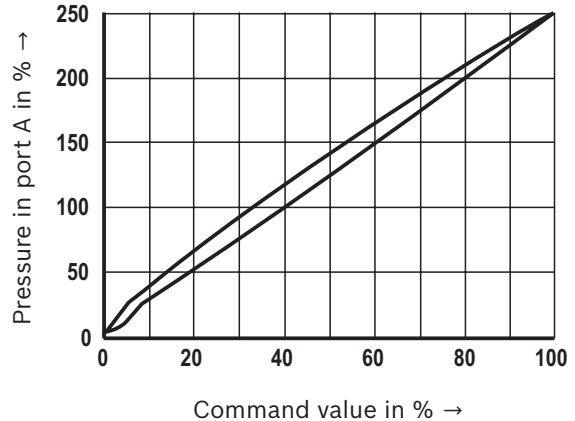

Characteristic curves

(measured with HLP46, $\vartheta_{oil} = 40 \pm 5 \text{ }^\circ\text{C}$, valve body and hydraulic fluid temperature-compensated. Large temperature differences may lead to differing characteristic curves/values.)

Pressure differential depending on the flow

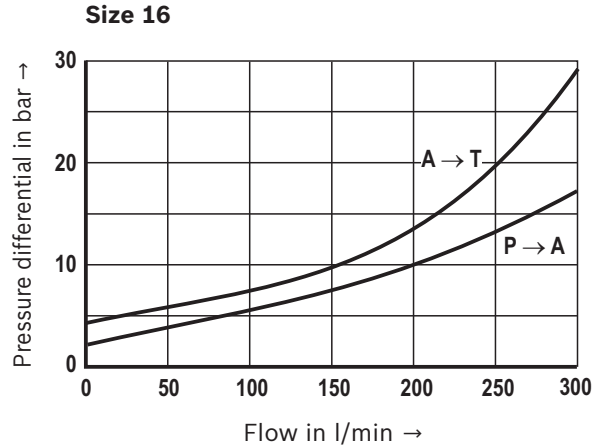
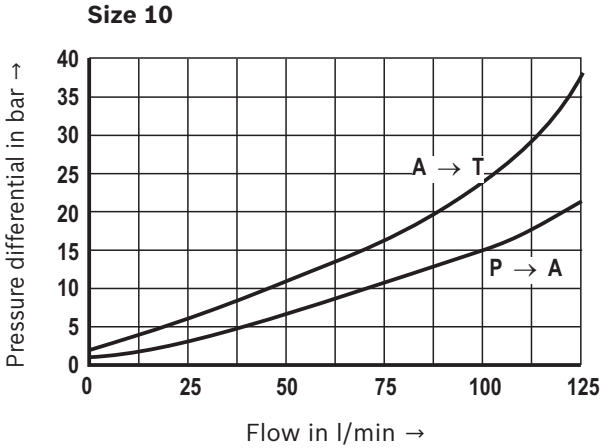

Pressure in port A depending on the flow

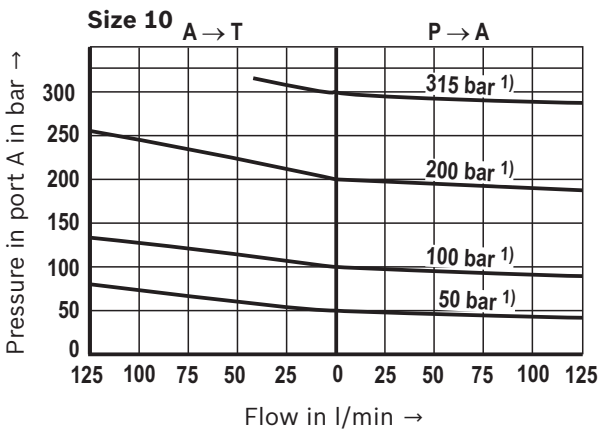

1) Pressure rating

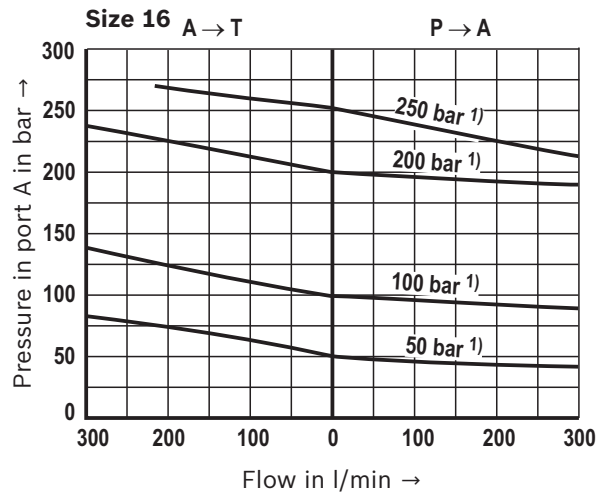

1) Pressure rating

Minimum set pressure depending on the flow with command value zero

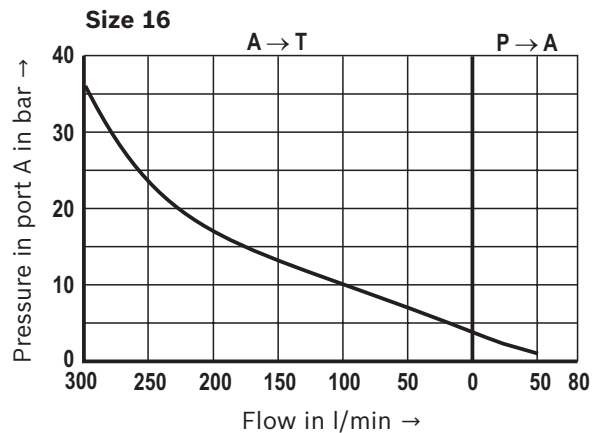
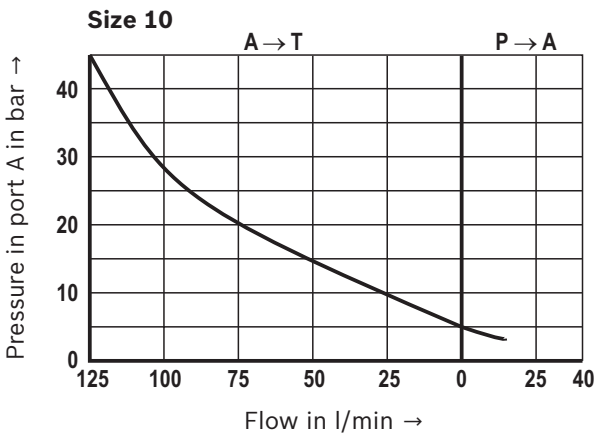

Dimensions: Size 10
(dimensions in mm)

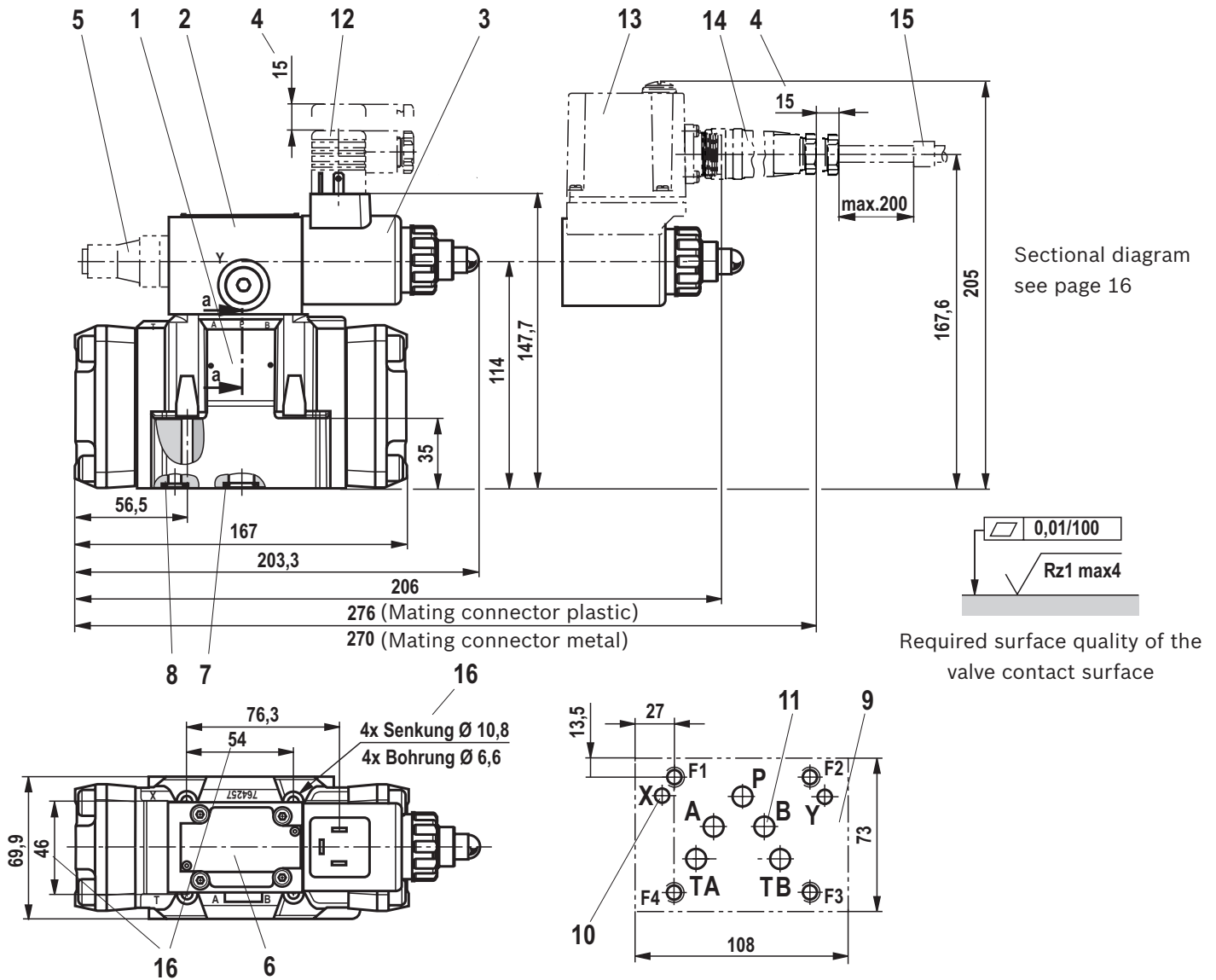

Sectional diagram
see page 16

Required surface quality of the
valve contact surface

- 1** Main valve
- 2** Pilot valve
- 3** Proportional solenoid
- 4** Space required for removing the mating connector
- 5** Maximum pressure limitation (type 3DREM...)
- 6** Name plate
- 7** Identical seal rings for port A, B, P, TA and TB
- 8** Identical seal rings for ports X and Y
- 9** Processed installation surface, porting pattern according to DIN 24340-A10 and ISO 4401-05-05-0-05
- 10** With "internal" pilot oil supply (version Y), port X in the subplate must be closed.
- 11** Port B must be closed in the subplate
- 12** Mating connector for type 3DRE(M) (separate order)
- 13** Integrated electronics (type 3DREE, 3DREME) with connector
- 14** Mating connector for type 3DRE(M)E, plastic or metal version (separate order)
- 15** Cable fastening
- 16** Connection diagram mounting screws

Notice!

The dimensions are nominal dimensions which are subject to tolerances.

Valve mounting screws and **subplates** see page 17.

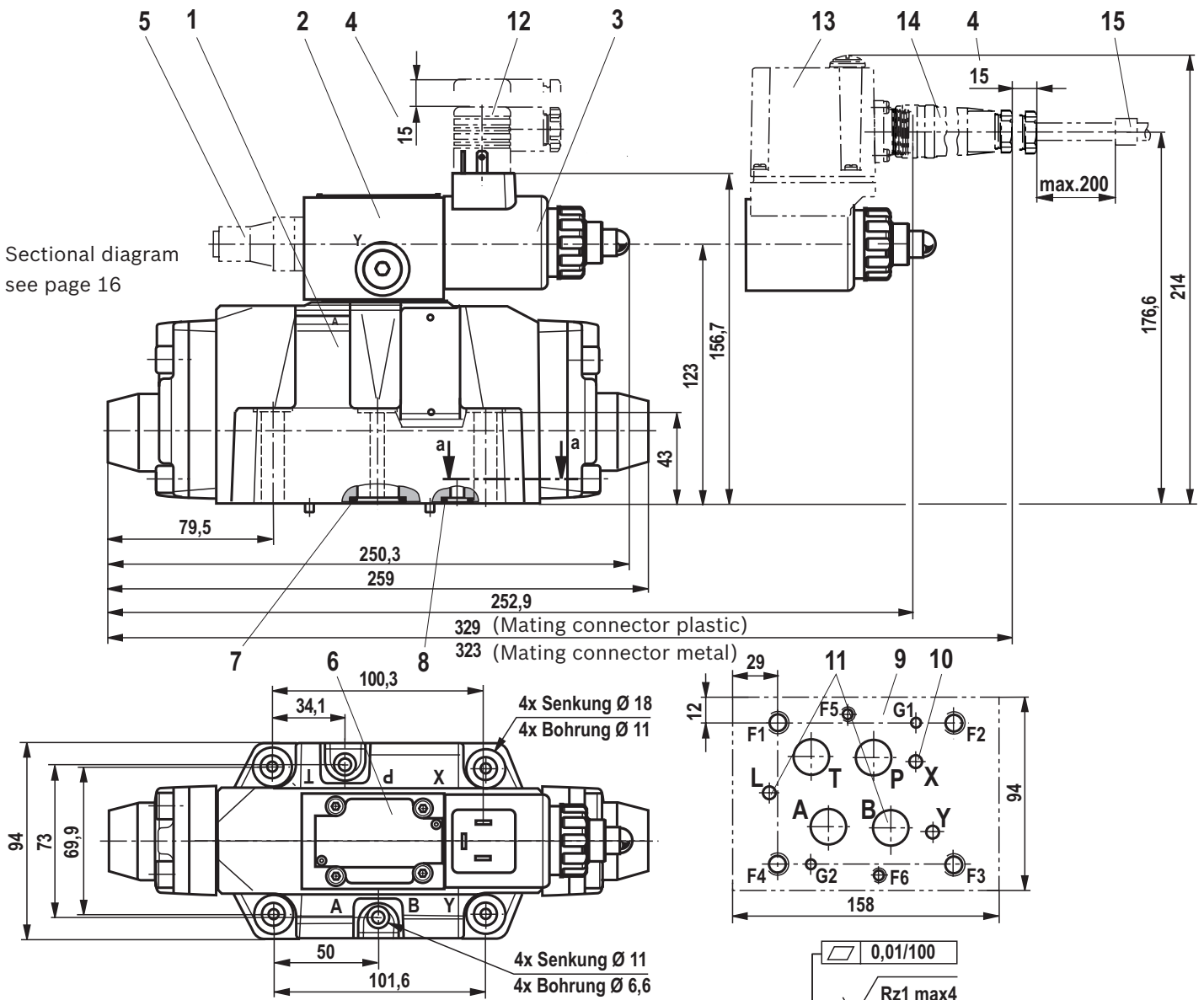
Dimensions: Size 16
 (dimensions in mm)

Required surface quality of the valve contact surface

- 1 Main valve
- 2 Pilot valve
- 3 Proportional solenoid
- 4 Space required for removing the mating connector
- 5 Maximum pressure limitation (type 3DREM...)
- 6 Name plate
- 7 Identical seal rings for ports A, B, P and T
- 8 Identical seal rings for ports X and Y
- 9 Processed installation surface, porting pattern according to DIN 24340-A16 and ISO 4401-05-07-0-05
- 10 With "internal" pilot oil supply (version Y), port X in the subplate must be closed.
- 11 Port B must be closed in the subplate
- 12 Mating connector for type 3DRE(M) (separate order)

- 13 Integrated electronics (type 3DREE, 3DREME) with connector
- 14 Mating connector for type 3DRE(M)E, plastic or metal version (separate order)
- 15 Cable fastening

Notice!

The dimensions are nominal dimensions which are subject to tolerances.

Valve mounting screws and **subplates** see page 17.

Pilot oil supply

Type 3DRE...-.../...XY **Pilot oil supply external, pilot oil return external**

In this version, the pilot oil is supplied from a separate control circuit (external).

The pilot oil return is not directed into the T channel of the main valve, but is separately directed to the tank via port Y (external).

Type 3DRE...-.../...Y... **Pilot oil supply internal, pilot oil return external**

With this version, the pilot oil is supplied from the P channel of the main valve (internally).

The pilot oil return is not directed into the T channel of the main valve, but is separately directed to the tank via port Y (external).

In the subplate, port X is to be closed.

Item **1**: Plug screw M6 DIN 906-8.8 SW 3

Size 10 Sectional diagram see page 14

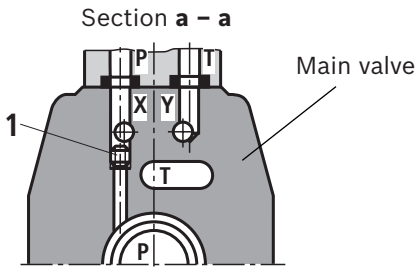

Pilot oil supply	external:	1 Closed
(section a – a)	internal:	1 Open
Pilot oil return	external	

Size 16 Sectional diagram see page 15

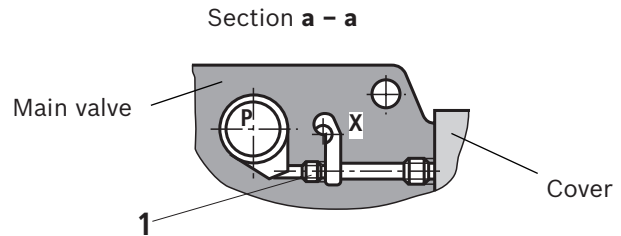

Pilot oil supply	external:	1 Closed
(section a – a)	internal:	1 Open
Pilot oil return	external	

Accessories

(not included in the scope of delivery)

Hexagon socket head cap screws (separate order)		Material number
Size 10	4x ISO 4762 - M6 x 45 - 10.9-fIZn-240h-L Friction coefficient $\mu_{\text{total}} = 0.09$ to 0.14; tightening torque $M_A = 12.5 \text{ Nm} \pm 10 \%$ or 4x ISO 4762 - M6 x 45 - 10.9 Friction coefficient $\mu_{\text{total}} = 0.12$ to 0.17; tightening torque $M_A = 15.5 \text{ Nm} \pm 10 \%$	R913000258 R00003263
Size 16	2x ISO 4762 - M6 x 60 - 10.9-fIZn-240h-L Friction coefficient $\mu_{\text{total}} = 0.09$ to 0.14; tightening torque $M_A = 12.2 \text{ Nm} \pm 10 \%$ 4x ISO 4762 - M10 x 60 - 10.9-fIZn-240h-L Friction coefficient $\mu_{\text{total}} = 0.09$ to 0.14; tightening torque $M_A = 59 \text{ Nm} \pm 10 \%$ or 2x ISO 4762 - M6 x 60 - 10.9 Friction coefficient $\mu_{\text{total}} = 0.12$ to 0.17; tightening torque $M_A = 15.5 \text{ Nm} \pm 10 \%$ 4x ISO 4762 - M10 x 60 - 10.9 Friction coefficient $\mu_{\text{total}} = 0.12$ to 0.17; tightening torque $M_A = 75 \text{ Nm} \pm 10 \%$	R913000115 R913000116 R00003266 R00008630

Notice: For reasons of stability, exclusively these valve mounting screws may be used. The tightening torque of the hexagon socket head cap screws refers to maximum operating pressure!

Subplates	Data sheet	Material number
Size 10	45054	
Size 16	45056	

External control electronics for type 3DRE	Data sheet	Material number
VT-MSPA1-11-1X/V0/0 in modular design	30223	
VT-VSPD-1-2X/V0/.0-1 in Euro-card format	30523	
VT-VSPA1-11-1X/V0/0 in Euro-card format	30100	

External control electronics for type 3DRE...G24-8	Data sheet	Material number
VT-2000-5X/... in Euro-card format	29904	
VT-MSPA1-1-30 in modular design	30224	

Mating connectors (details see page 8)	Data sheet	Material number
For type 3DRE: Mating connectors according to DIN EN 175301-803	08006	R901017011
For type 3DREE: Mating connectors according to DIN EN 175201-804	08006	R900021267 (plastic) R900223890 (metal)

Bosch Rexroth AG
Hydraulics
Zum Eisengießer 1
97816 Lohr am Main, Germany
Phone +49 (0) 93 52/ 18-0
documentation@boschrexroth.de
www.boschrexroth.de

© This document, as well as the data, specifications and other information set forth in it, are the exclusive property of Bosch Rexroth AG. It may not be reproduced or given to third parties without its consent.
The data specified above only serve to describe the product. No statements concerning a certain condition or suitability for a certain application can be derived from our information. The information given does not release the user from the obligation of own judgment and verification. It must be remembered that our products are subject to a natural process of wear and aging.

Bosch Rexroth AG
Hydraulics
Zum Eisengießer 1
97816 Lohr am Main, Germany
Phone +49 (0) 93 52 / 18-0
documentation@boschrexroth.de
www.boschrexroth.de

© This document, as well as the data, specifications and other information set forth in it, are the exclusive property of Bosch Rexroth AG. It may not be reproduced or given to third parties without its consent.

The data specified above only serve to describe the product. No statements concerning a certain condition or suitability for a certain application can be derived from our information. The information given does not release the user from the obligation of own judgment and verification. It must be remembered that our products are subject to a natural process of wear and aging.

Bosch Rexroth AG
Hydraulics
Zum Eisengießer 1
97816 Lohr am Main, Germany
Phone +49 (0) 93 52/ 18-0
documentation@boschrexroth.de
www.boschrexroth.de

© This document, as well as the data, specifications and other information set forth in it, are the exclusive property of Bosch Rexroth AG. It may not be reproduced or given to third parties without its consent.

The data specified above only serve to describe the product. No statements concerning a certain condition or suitability for a certain application can be derived from our information. The information given does not release the user from the obligation of own judgment and verification. It must be remembered that our products are subject to a natural process of wear and aging.