

PRO-ELEC



Model No. PEL00581

**NON MAINTAINED TWIN SPOTLIGHT
WALL MOUNT LED EMERGENCY LIGHT**

Please read these instructions carefully before starting installation and retain for future reference. The centre page test record can be removed and kept with the building fire safety records.

IMPORTANT SAFETY INFORMATION

RISK OF ELECTRICAL SHOCK. ALWAYS ISOLATE THE POWER AT THE MAINS BEFORE INSTALLING OR MAINTAINING THIS EMERGENCY LIGHT.

- This product must be installed by a competent person in accordance with the Building Regulations and the current edition of the IET Wiring Regulations (BS7671).
- This product is suitable for mounting on normally flammable surfaces such as wood, plasterboard or masonry.
- Emergency light fittings should have their own separate mains circuit, protected with an appropriate MCB or fuse. They should not share their supply with other lighting or electrical equipment.
- The emergency light is suitable for connection to a 220-240V~ 50Hz.
- This emergency light is for indoor use only.
- This product will only illuminate in the event of a mains failure (non-maintained).
- Ensure that after installation the emergency light remains accessible for regular maintenance and testing.

INSTALLATION

NOTE: Before drilling any holes, check that there are no hidden obstructions behind the mounting surface such as pipes or cables.

1. Undo the four screws on the front of the main body and lift the panel off.
2. The position of the cable entry and fixing holes are marked on the case. Remove and open out as required.
3. Using the back of the product as a template, mark the position of the fixing holes on your mounting surface (see fig 1).
4. Drill the fixing holes and fit wall plugs as appropriate.
5. Secure the back of the product to the mounting surface using suitable fixings (not supplied).
6. Fit a cable gland (not supplied) into the cable entry hole. Apply silicone sealant to the fixings if moisture or weatherproofing is required.
7. Thread the supply cable through into the product and fit the cable retainer.
8. Make connection to the supply using the terminal block on the PCB. Ensure that the correct polarities are observed i.e.:
 - Brown – Live terminal 'L'
 - Blue – Neutral terminal 'N'
9. Write the current date on the battery pack.
10. Connect the battery pack terminal connector to the connector on the PCB.
11. Fit the front cover and restore the power supply. The green LED should light to show the battery is being charged.
12. Perform the electrical tests specified in the Wiring Regulations (BS7671).

**Test Record Sheet on reverse
PULL OUT**

Installation, maintenance a

Location:

Installation date:

Installed by:

		20__		20__		2
Month	Test	Sign	Date	Sign	Date	S
1	Short					
2	Short					
3	Short					
4	Short					
5	Short					
6	1 h					
7	Short					
8	Short					
9	Short					
10	Short					
11	Short					
12	3h					

**Test Record Sheet on reverse
PULL OUT**

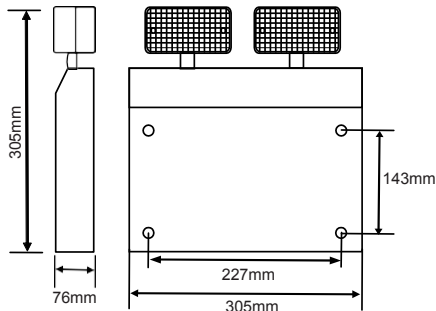

Fig 1. Dimensions

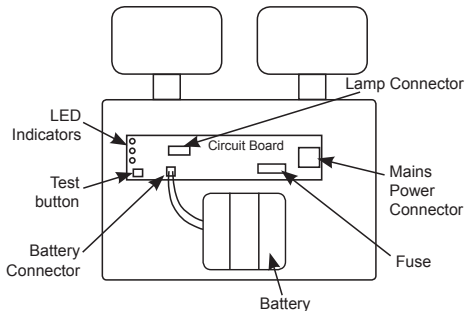

Fig 2. Internal Layout

OPERATIONAL CHECKS

Note: This equipment must be checked regularly in compliance with local regulation and codes of practice. For your own safety, testing should occur during the day.

The LED's can be tested by pressing the TEST button on the bottom of the case.

- After installation, you should allow 24 hours for the battery pack to charge fully before testing.
- Isolate the power supply and check that the lamp remains illuminated for at least three hours. Restore the power supply.
- Each day: Check that the green charging LED is lit.
- Each month (short test): Isolate the power supply and check that the lamp remains illuminated. Record the results on the test record sheet included with these instructions.
- Every six months: Isolate the power supply and check that the lamp remains illuminated after 1 hour. Record the results on the included test record.
- Once each year: Isolate the power supply and check that the lamp is still illuminated after 3 hours. Record the results on the included test record.

Please keep these test records in a safe place. A fire officer or other authorised person may want to see your record of inspection and testing.

CLEANING AND MAINTENANCE

- Clean the product with a soft, dry cloth only. Do not use any solvents or abrasive chemical cleaners.
- The LED lamps in this product are non-replaceable.

Changing the battery

- If after a routine operation check, the lamp does not remain lit for the 3 hour period, a new battery pack may be required. Change the battery pack as follows:
 1. Isolate from the mains supply.
 2. Remove the front panel.
 3. Unplug the battery pack connector from the PCB.
 4. Remove the old battery pack.
 5. Write the current date on the new battery pack.
 6. Secure the new battery pack in position and connect the wiring terminal connector.
 7. Refit the cover. Make sure that the screws are securely fastened.
 8. Restore mains power and allow to charge for 24 hours.
 9. Perform the full operation check and update the test record.

Changing the fuse

1. Isolate from the mains supply.
2. Remove the front cover.
3. Remove the fuse from it's housing and replace with one of the same type (240V F3A).
4. Refit the front cover making sure that it is securely screwed in place.
5. Test the operation.

Self Test Fault Warning

- If the battery has failed, the alarm will sound at one minute intervals and the yellow indicator LED will flash. If the main lamp LED has failed, the alarm will sound every half minute and the yellow indicator will flash at about 1 second intervals.
- The fault alarm may be silenced using the test switch.

Manual Test Operation:

- Press the "Test" button for 1 second: green LED will go off and a lamp test will run briefly.
- Press the "Test" button for 3 seconds: green LED will flash and a function test will run for 30 second simulating a mains power failure.
Press the "Test" button for 5 seconds: green LED will flash and a battery duration test will run for 3 hours.
- Press the "Test" button for 10 seconds, all 3 LED indicators will flash 3 times and the lamps and functions will be reset to normal operation.

SPECIFICATIONS

Input voltage:	220-240V~, 50Hz
Rated power:	5W
Lamps:	SMD2835 LEDs x 60pcs
Luminous flux:	600 lm
Continuous emergency illumination:	> 3 hours (when the battery is fully charged)
Battery pack:	Ni-Cd, 3.6V, 6Ah
Recharge time:	24 hours – approx.
Ambient temperature:	0 - 35°C
Over-discharge protection:	Yes
Ingress protection rating:	IP65



INFORMATION ON WASTE DISPOSAL FOR CONSUMERS OF ELECTRICAL & ELECTRONIC EQUIPMENT.



When this product has reached the end of its life it must be treated as Waste Electrical & Electronic Equipment (WEEE). Any WEEE marked products must not be mixed with general household waste, but kept separate for the treatment, recovery and recycling of the materials used. Waste batteries can be returned to any waste battery recycling point which are provided by most battery retailers. Contact your local authority for details of battery and recycling schemes in your area.



Made in China. PR2 9PP

Man Rev 1.0