

ECN/PCN No.: M1228

For Manufacturer			
<b>Product Description:</b>  <div style="text-align: center; color: blue; font-weight: bold;">           RJ45, 1x4 Multi Port,            100/1000/2.5G/5G Base-T            Magnetics Module         </div>	<b>Abracon Part Number / Part Series:</b>  <div style="text-align: center; color: blue; font-weight: bold;">           ARJM14 series         </div>	<input type="checkbox"/> Documentation only <input checked="" type="checkbox"/> ECN <input type="checkbox"/> EOL	<input type="checkbox"/> Series <input checked="" type="checkbox"/> Part Number(s)
<b>Affected Revision:</b> Initial revision	<b>New Revision:</b> A	<b>Application:</b>	<input type="checkbox"/> Safety <input checked="" type="checkbox"/> Non-Safety

**Prior to Change:**

**Electrical Specifications**

Parameters	Minimum	Typical	Maximum	Units	Notes
Turn Ratio (±3%)	1CT:1CT				100kHz, 0.1V
Inductance	350			μH	100kHz, 0.1V, 8mADC
	200				For 2.5G Base-T only
	160				For 5G Base-T only
Leakage Inductance			0.5	μH	100kHz, 0.1V
			0.3		For 2.5G Base-T and 5G Base-T
DC Resistance			1.5	Ω	
Hipot	2250			VDC	1mA Max Complies with IEEE 802.3
Operating Temperature	-40		+85	°C	See options
Storage Temperature	-40		+85	°C	
<b>100 Base-T</b>					
Insertion Loss	-1.1			dB	0.5-100MHz
Return Loss			-18	dB	0.5-30MHz
			$-18+20\log(f/30)^*$		30.1-60MHz
			-12		60.1-80MHz
Crosstalk			-35	dB	0.5-40MHz
			$-33+20\log(f/50)^*$		40.1-100MHz
CMRR			-30	dB	0.5-100MHz
<b>1000 Base-T</b>					
Insertion Loss	-1.1			dB	0.5-100MHz
Return Loss			-18	dB	0.5-40MHz
			$-12+20\log(f/80)^*$		40.1-100MHz
Crosstalk			-35	dB	0.5-40MHz
			$-33+20\log(f/50)^*$		40.1-100MHz
CMRR			-30	dB	0.5-100MHz
<b>2.5G Base-T</b>					
Insertion Loss	-0.5			dB	1-50MHz
	-1.0				50-125MHz
Return Loss			-20	dB	1-40MHz
			$-20+15\log(f/40)^*$		40-200MHz
Crosstalk			-30	dB	25-125MHz
<b>5G Base-T</b>					
Insertion Loss	-0.5			dB	1-50MHz
	-1.0				50-125MHz
	-2.0				125-250MHz
Return Loss			-20	dB	1-40MHz

		$-20+15\log(f/40)^*$	
Crosstalk		-30	dB
		-25	

### Part Number Identification

ARJM14   -   -     -    

**ARJM14**

Mechanical Series	Schematics	Left LED color	Right LED color	Operating Temperature	Gold Plating
A1: Tab down, w/ EMI Fingers	009: 100 Base-T	N: No LED	N: No LED	CW: 0 ~ 70 °C	2: 6u"
A2: Tab down, w/o EMI Fingers	502: 1000 Base-T	A: Green	A: Green	EW: -40 ~ 85 °C	
A3: Tab up w/ EMI Fingers	805: 2.5G Base-T	B: Yellow	B: Yellow		
A4: Tab up w/o EMI Fingers	811: 5G Base-T				

See Mechanical Dimension Section for Details

See Schematic Section for Details

### Mechanical Dimensions

**A1: 1 x 4, w/ EMI Fingers**

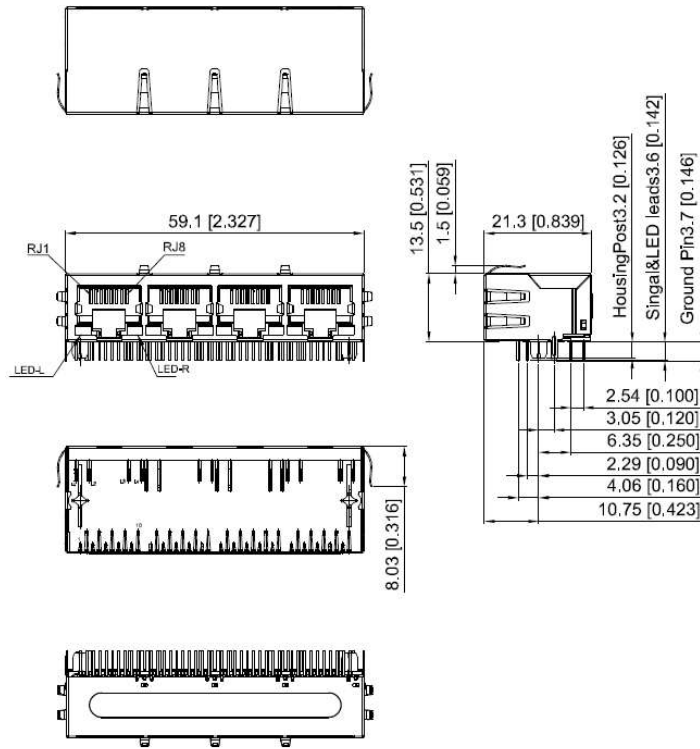

Recommended layout

100-Base-T w/o LEDs

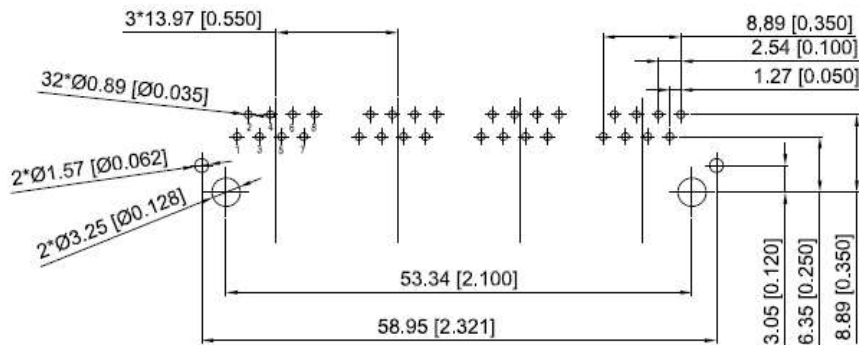

1000Base-T with LEDs

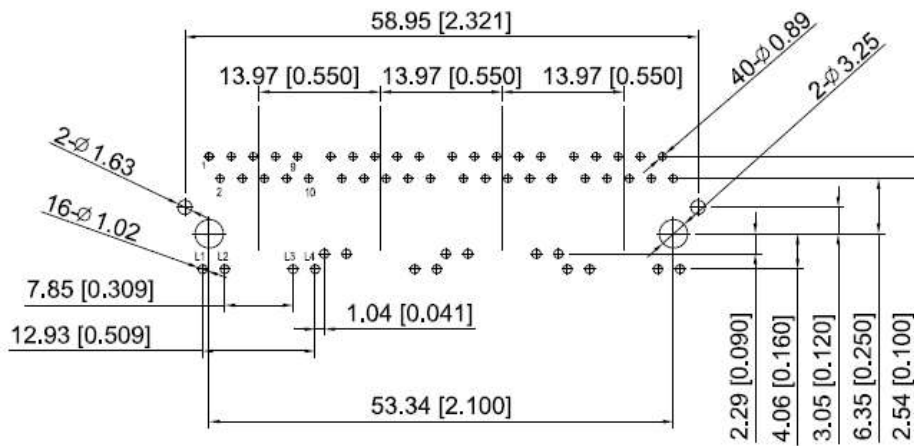

**After Change:**
**Electrical Specifications**

Parameters	Minimum	Typical	Maximum	Units	Notes
Turn Ratio ( $\pm 3\%$ )	1CT:1CT				100kHz, 0.1V
Inductance	350			$\mu\text{H}$	100kHz, 0.1V, 8mADC
Hipot	2250			VDC	1mA Max Complies with IEEE 802.3
Operating Temperature	-40		+85	$^{\circ}\text{C}$	See options
Storage Temperature	-40		+85	$^{\circ}\text{C}$	
Insertion Loss	-1.0			dB	0.3-100MHz
Return Loss			-18	dB	1-30MHz
			-16		30-60MHz
			-12		60-80MHz
			-10		80-100MHz
Crosstalk			-30	dB	1-100MHz
CMRR			-30	dB	1-100MHz

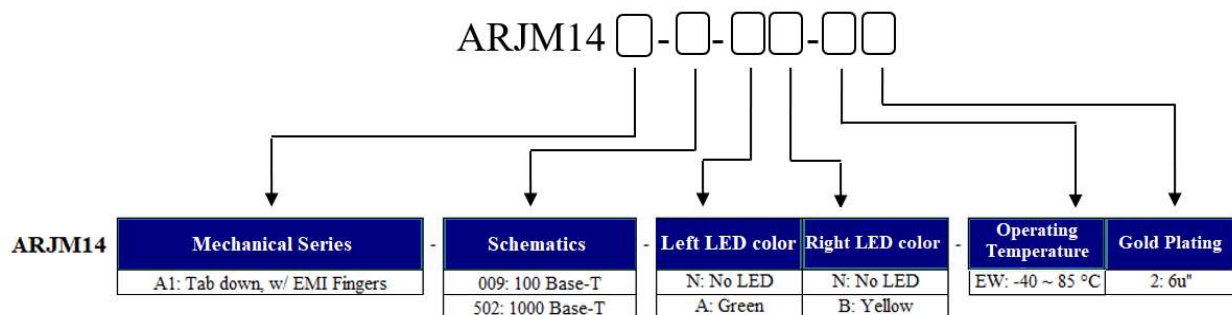
**Part Number Identification**

See Mechanical Dimension Section for Details

See Schematic Section for Details

**Mechanical Specifications**

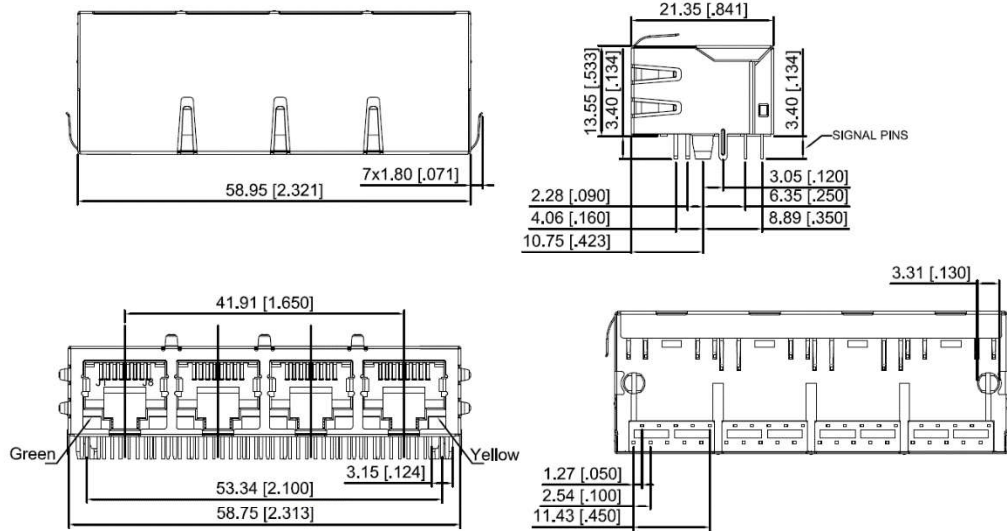

---

**A1: 1 x 4, w/ EMI Fingers**

Dimensions are in mm[inches]. Unless otherwise noted, tolerance is  $\pm 0.25\text{mm}$ [0.010]

**Recommended Layout**

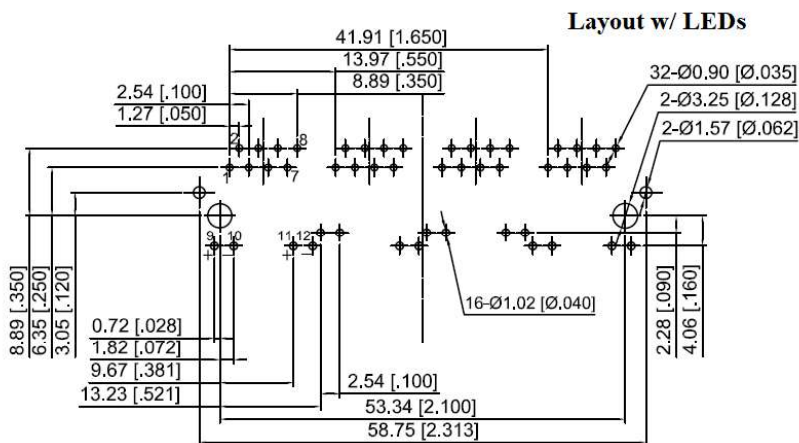
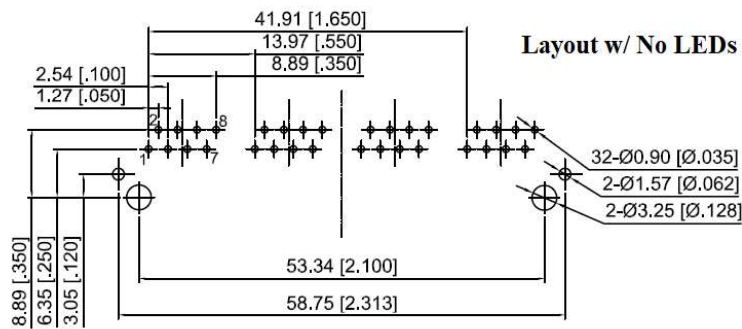
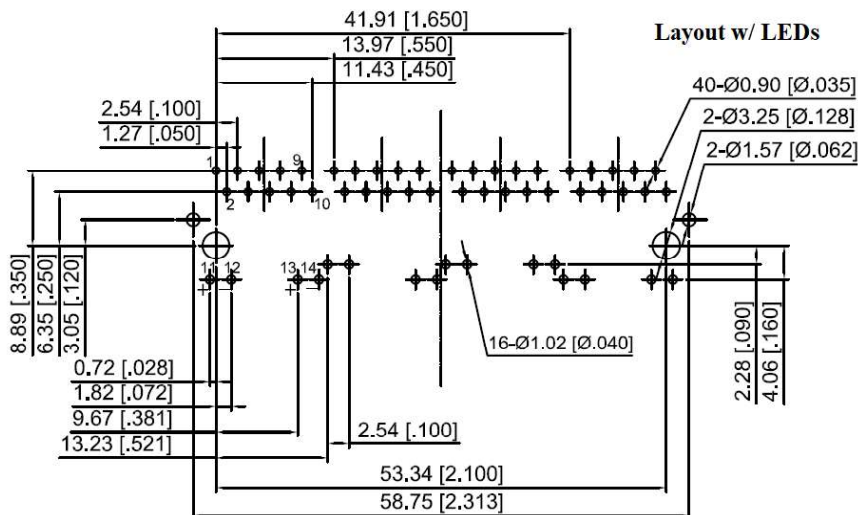
---

**10/100 Base-T**

**1000 Base-T**

Dimensions are in mm[inches]. Unless otherwise noted, tolerance is  $\pm 0.25\text{mm}[0.010]$

**Cause/Reason for Change:**

Moving to new production line.

Change Plan		
<b>Effective Date:</b> <div style="text-align: center;">3/19/2021</div>	<b>Additional Remarks:</b>	
<b>Change Declaration:</b>  Changes described in this document do not adversely affect the products form, fit or function.  <b>There is a partial EOL associated with this ECN. (Refer to Partial ECN-EOL #M1228 ARJM14 Series: <a href="https://abracon.com/downloads/ECN-PCN/Partial-ECN-EOL-M1228-ARJM14-Series.pdf">https://abracon.com/downloads/ECN-PCN/Partial-ECN-EOL-M1228-ARJM14-Series.pdf</a>.)</b>		
<b>Issued Date:</b> <div style="text-align: center;">3/19/2021</div>	<b>Issued By:</b> <div style="text-align: center;"><i>Gerald Capwell</i></div>	<b>Issued Department:</b> <div style="text-align: center;">Engineering</div>
<b>Approval:</b> <div style="text-align: center;"><i>Syed Raza</i> Engineering VP</div>	<b>Approval:</b> <div style="text-align: center;"><i>Reuben Quintanilla</i> Quality Director</div>	<b>Approval:</b> <div style="text-align: center;"><i>Ying Huang</i> Purchasing Director</div>
For Abracon EOL only		
<b>Last Time Buy (if applicable):</b>		<b>Alternate Part Number / Part Series:</b>
<b>Additional Approval:</b>	<b>Additional Approval:</b>	<b>Additional Approval:</b>
Customer Approval (If Applicable)		
<b>Qualification Status:</b> <div style="text-align: center;"> <input type="checkbox"/> Approved <input type="checkbox"/> Not accepted           </div> <i>Note: It is considered approved if there is no feedback from the customer 1 month after ECN/PCN is released.</i>		
<b>Customer Part Number:</b>		<b>Customer Project:</b>
<b>Company Name:</b>	<b>Company Representative:</b>	<b>Representative Signature:</b>
<b>Customer Remarks:</b>		