

PoESP32

SKU:U138



Description

PoESP32 Unit is an ESP32 Ethernet Unit supports PoE (Power Over Ethernet). This module adopts ESP32 as built-in MAC, and IP101G as physical layer transceiver. Default firmware with **ESP-AT** , supports TCP, MQTT, HTTP protocols. It can connect to server with simple AT commands through serial port, achieving data transmission and remote control functions. This module simplify wiring and saves labor cost with PoE power supply, and It reserves the ability for secondary development to meet your requirement.

Product Features

- Embedded ESP32 main controller
- PHY solution:
 - Transceiver model IP101G
 - IEEE 802.3/802.3u standard
- Ethernet Interface.
 - PoE standard: PoE IEEE802.3 AF / Support maximum load power 6W
 - RJ45 network port 10/100Mbps
- Communication / download interface:
 - Default firmware is ESP-AT / Support secondary development to implement TCP Client/HTTP/CoAP and other protocols
 - Programmable / support secondary development, reserve program download interface
- Power supply.
 - HY2.0-4P interface 5V DC power supply

- PoE power supply (PoE IEEE802.3 AF)
- Development method.
 - AT command, UART: 9600bps default
 - Development Platform: UIFlow(coming soon), Arduino, ESP-IDF

Included

- 1x UNIT PoESP32
- 1x HY2.0-4P Cable (20cm)
- 1x Instruction manual

Applications

- Ethernet Controller
- TCP Client data passthrough

Specification

Specifications	Parameters
ESP32-WROOM-32U	240MHz dual core, 600 DMIPS, 520KB SRAM (without integrated 3D antenna, does not support WiFi wireless function)
Flash	4MB
PHY	IP101G: IEEE 802.3/802.3u
MAC-PHY Interface Type	RMII
PoE Specifications	PoE IEEE802.3 AF Specifications / Maximum Power 6W / Voltage DC 37-57V
Ethernet Interface Specifications	RJ45 10/100Mbps
Reserved	1x HY2.0-4P interface, 1x program download interface

interface Specifications	Parameters
Communication interface	UART 9600bps 8N1 AT command control
Communication logic level	3.3V
Net Weight	26.2g
Gross Weight	32.8g
Product size	72 * 26 * 19.2mm
Packing Size	75 * 36 * 20.5mm



PinMap

- IP101G (ETH_ADDR = 1)

IPG101G (RMII PHY)	ESP32
TX_EN	G21
TX0	G19
TX1	G22
RX0	G25
RX1	G26
CRS_DV	G27

IPG101G (SMI)	ESP32
---------------	-------

MDC
IPG101G (SMD)

G23
ESP32

MDIO

G18

- HY2.0-4P

PoESP32	RXD	TXD
M5CORE	G16	G17

Schematic

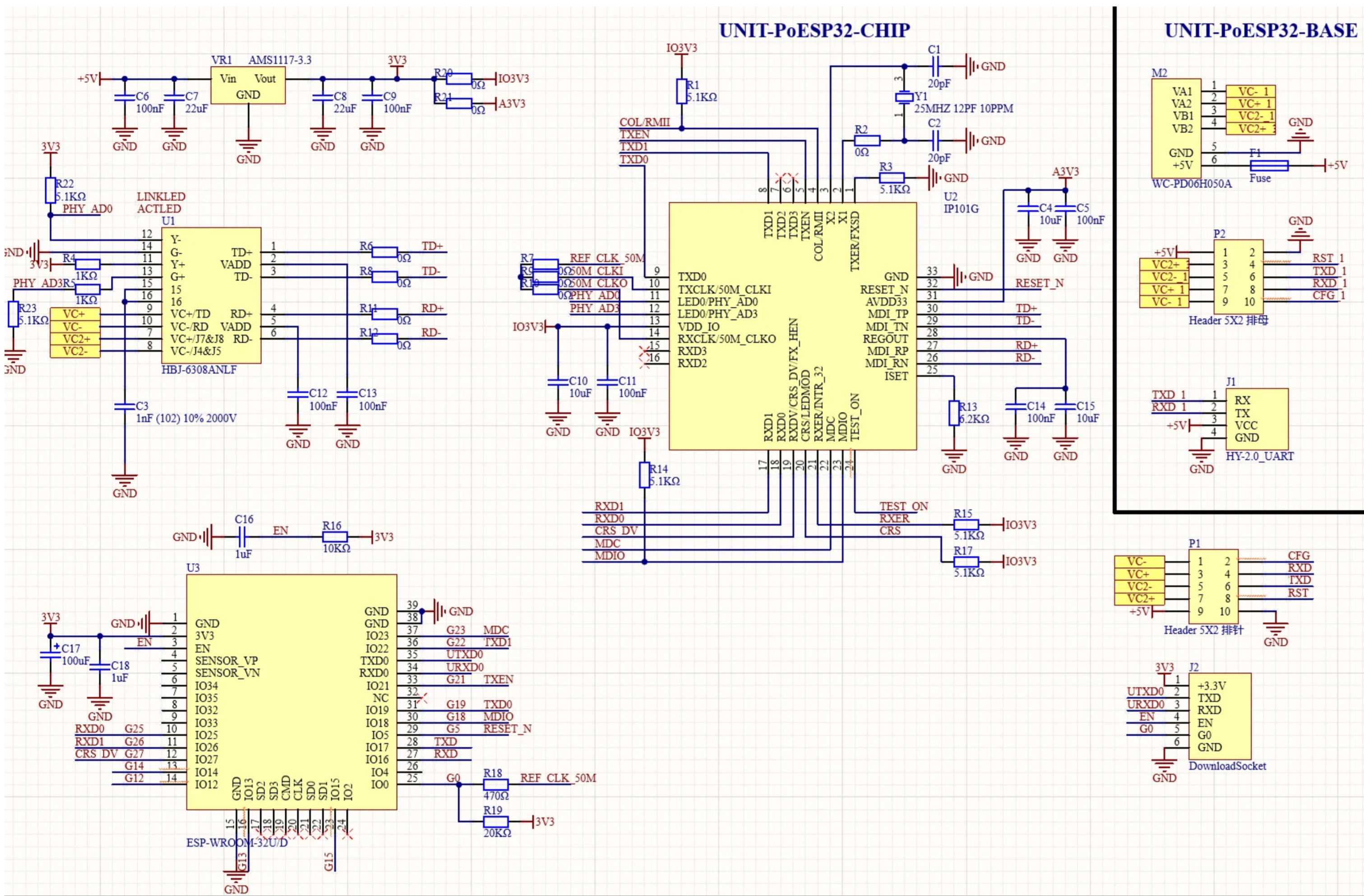

Related Link

- [Datasheet](#)
 - [ESP32-WROOM-32U/D](#)
 - [IP101G](#)

Example

Arduino

- [TCP Client](#)
 - [PoESP32 with M5Core - TCP Client](#)
 - [PoESP32 with M5Core2 - TCP Client](#)

- [PoESP32 with M5Atom - TCP Client](#)
- [PoESP32 with M5StickC - TCP Client](#)
- [PoESP32 with M5StickC Plus - TCP Client](#)
- HTTP Client
 - [PoESP32 with M5Core - MQTT Client](#)
 - [PoESP32 with M5Core2 - MQTT Client](#)
 - [PoESP32 with M5Atom - MQTT Client](#)
 - [PoESP32 with M5StickC - MQTT Client](#)
 - [PoESP32 with M5StickC Plus - MQTT Client](#)
- MQTT Client
 - [PoESP32 with M5Core - MQTT Client](#)
 - [PoESP32 with M5Core2 - MQTT Client](#)
 - [PoESP32 with M5Atom - MQTT Client](#)
 - [PoESP32 with M5StickC - MQTT Client](#)
 - [PoESP32 with M5StickC Plus - MQTT Client](#)

Firmware

- [ESP-AT Github](#)
- [ESP-AT Documentation](#)

| FAQ