



Model Number

NBN40-U1-E2-M

Features

- Sensor head bidirectional and rotatable
- 40 mm non-flush
- E1-Type approval
- Extended temperature range - 40 ... +85 °C
- 4 LEDs indicator for 360° visibility

Accessories

MHW 01

Modular mounting bracket

Technical Data

General specifications

Switching element function	PNP	NO
Rated operating distance	s_n	40 mm
Installation		non-flush
Output polarity		DC
Assured operating distance	s_a	0 ... 32.4 mm
Reduction factor r_{Al}		0.34
Reduction factor r_{Cu}		0.3
Reduction factor r_{304}		0.81
Reduction factor r_{S37}		1
Reduction factor r_{Brass}		0.4

Nominal ratings

Operating voltage	U_B	10 ... 60 V DC
Switching frequency	f	0 ... 150 Hz
Hysteresis	H	typ. 5 %
Reverse polarity protection		reverse polarity protected
Short-circuit protection		pulsing
Voltage drop	U_d	≤ 2 V
Operating current	I_L	0 ... 200 mA
Off-state current	I_r	0 ... 0.5 mA
No-load supply current	I_0	≤ 20 mA
Operating voltage indicator		LED, green
Switching state indicator		LED, yellow

Functional safety related parameters

MTTF _d	880 a
Mission Time (T_M)	20 a
Diagnostic Coverage (DC)	0 %

Ambient conditions

Ambient temperature	-40 ... 85 °C (-40 ... 185 °F)
---------------------	--------------------------------

Mechanical specifications

Connection type	screw terminals
Core cross-section	≤ 2.5 mm ²
Housing material	PA/metal with epoxy powder coating
Sensing face	PA-GF35
Housing base	plastic
Degree of protection	IP68 / IP69K
Mass	225 g
Note	Tightening torque: 1.8 Nm (housing) Tightening torque: 1.0 Nm (Screw terminal)

Compliance with standards and directives

Standard conformity	
Standards	EN 60947-5-2:2007 IEC 60947-5-2:2007

Approvals and certificates

UL approval	cULus Listed, General Purpose
CSA approval	cCSAus Listed, General Purpose
CCC approval	Certified by China Compulsory Certification (CCC)
E1 Type approval	10R-04

Dimensions

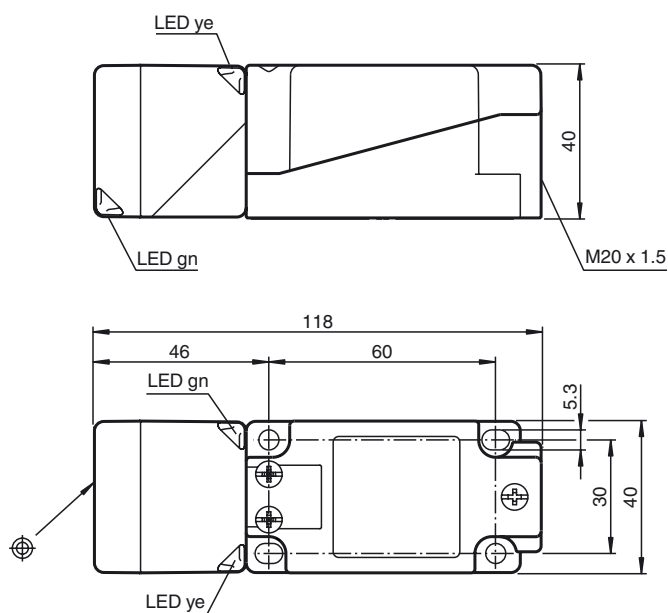

Electrical Connection

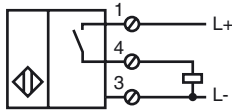

Installation Hint

Emitted interference and interference immunity in accordance with motor vehicle directive 2006/28/EG (e1 Type approval)
 Interference immunity in accordance with DIN ISO 11452-2: 100 V/m
 Frequency band 20 MHz up to 2 GHz

Mains-borne interference in accordance with ISO 7637-2: Pulse

	1	2a	2b	3a	3b	4	5
Severity level	III	III	III	III	III	III	IV
Failure criterion	C	A	C	A	A	A	C

EN 61000-4-2:	CD: 8 kV / AD: 15 kV
Severity level	IV IV
EN 61000-4-3:	30 V/m (80...2500 MHz)
Severity level	IV
EN 61000-4-4:	2 kV
Severity level	III
EN 61000-4-6:	10 V (0.01...80 MHz)
Severity level	III
EN 55011:	Class A