

MC122032CA6W-SPTLY	122 x 32	LCD Module	
Specification			
Version: 2		Date: 06/05/2021	
Revision			
1	26/11/2020	First Issue	
2	04/05/2021	Spec Update	

Display Features			
Resolution	122 x 32		
Appearance	Black on Yellow/Green		
Logic Voltage	5V		
Interface	Parallel		
Font Set	N/A		
Display Mode	Transflective		
LC Type	STN		
Module Size	59.00 x 29.30 x 5.50 mm		
Operating Temperature	-20°C ~ +70°C		
Construction	COB		
LED Backlight	Yellow

* - For full design functionality, please use this specification in conjunction with the SBN1661G specification. (Provided Separately)

Display Accessories	
Part Number	Description

Optional Variants	
Appearances	Voltage



FUNCTIONS & FEATURES

- LCD TYPE:
- Driving Scheme : 1/32 Duty, 1/5Bias
- Viewing direction : 6 O'clock
- Power Supply Voltage : 5.0V
- LCD Operation Voltage : 4.35V
- Interface : 68-type Parallel
- RoHS Compliant

MECHANICAL SPECIFICATIONS

- Module Size : 59.00(L) x 29.300 (W) x 5.5 (H) mm
- Viewing Area : 52.00(L) x 15.00(W) mm
- Active Area : 45.72(L) x 11.97 (W) mm
- Dot Pitch : 0.375(W) x 0.375(H) mm
- Dot Size : 0.345(W) x 0.345 (H) mm
- Dot Gap : 0.030*0.030mm

MIDAS
DISPLAYS

EXTERNAL DIMENSIONS

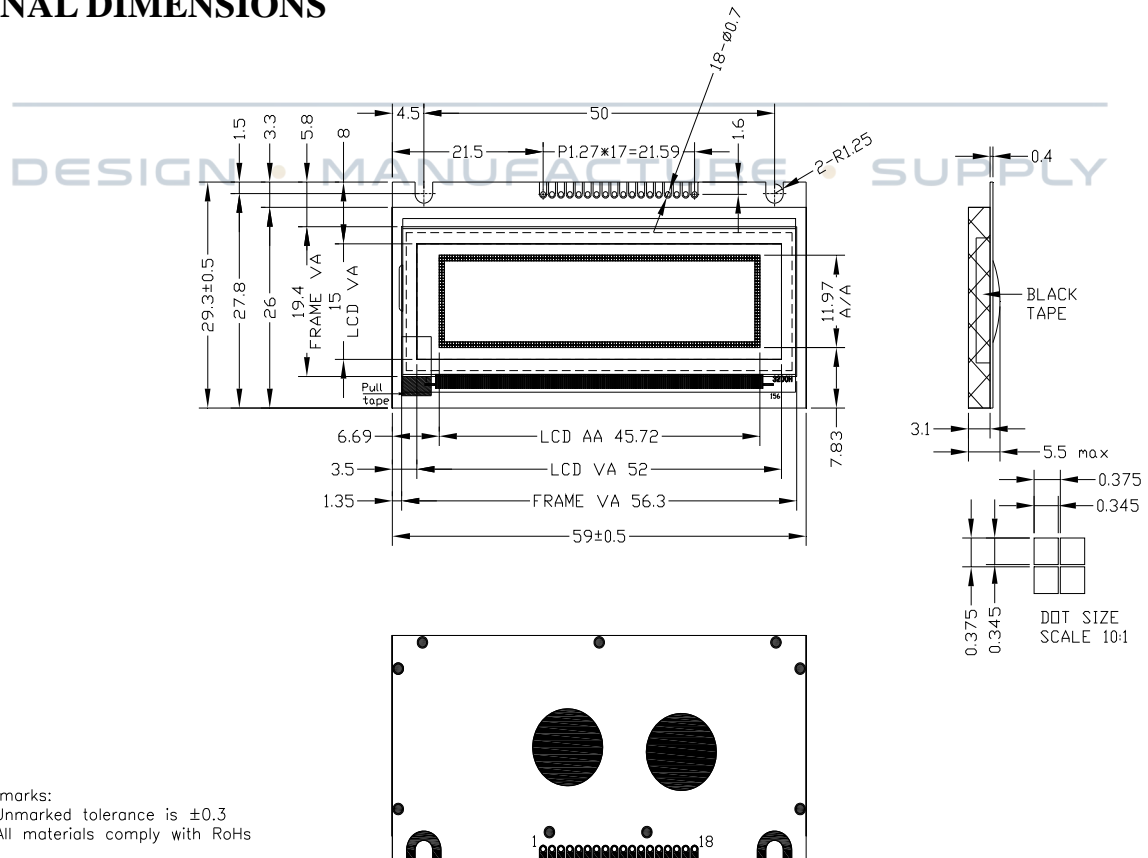

BLOCK DIAGRAM

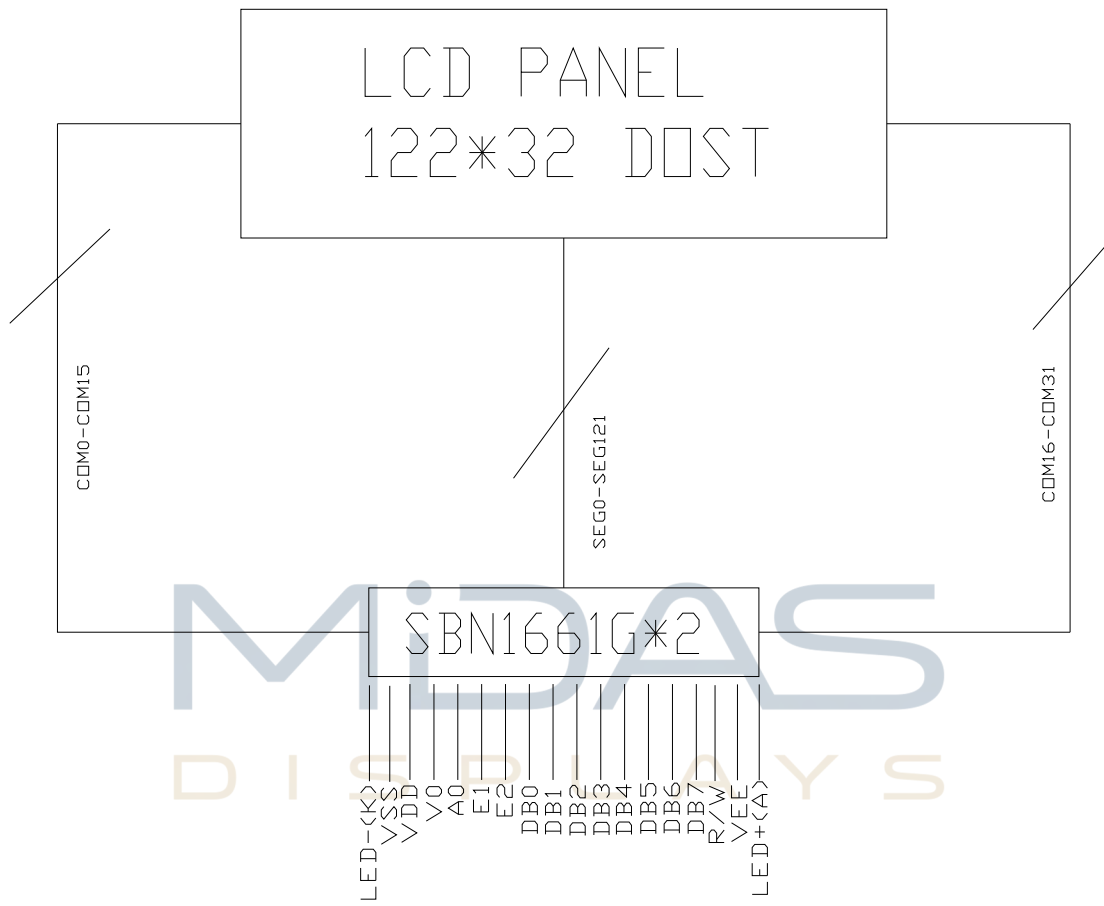

DESIGN • MANUFACTURE • SUPPLY



PIN ASSIGNMENT

Pin No.	Symbol	Level	Description
1	LED-(K)	—	Cathode of LED backlight
2	VSS	0V	Ground
3	VDD	5.0V	Power supply for logic; VLED+ supply.
4	Vo	(Variable)	Contrast Adjustment
5	A0	H/L	H : Data L : Instruction
6	E1	H/L	Chip select signal for IC1 (left 61*32 dots) active "H"
7	E2	H/L	Chip select signal for IC2 (right 61*32 dots) active "H"
8	DB0	H/L	Data bus line
9	DB1	H/L	Data bus line
10	DB2	H/L	Data bus line
11	DB3	H/L	Data bus line
12	DB4	H/L	Data bus line
13	DB5	H/L	Data bus line
14	DB6	H/L	Data bus line
15	DB7	H/L	Data bus line
16	R/W	H/L	H : Read ; L : Write
17	VEE	—	Negative voltage output
18	NC	—	No connection



Item	Symbol	MIN.	TYP.	MAX.	Unit	Condition
Forward Curret	I _f	15*2	20*2	30*2	mA	V _f =5.0V
Dominant Wave Length	λ _D	565	570	575	nm	
Uniformity	Avg		70		%	
Luminance	L _v	30	70		cd/m ²	

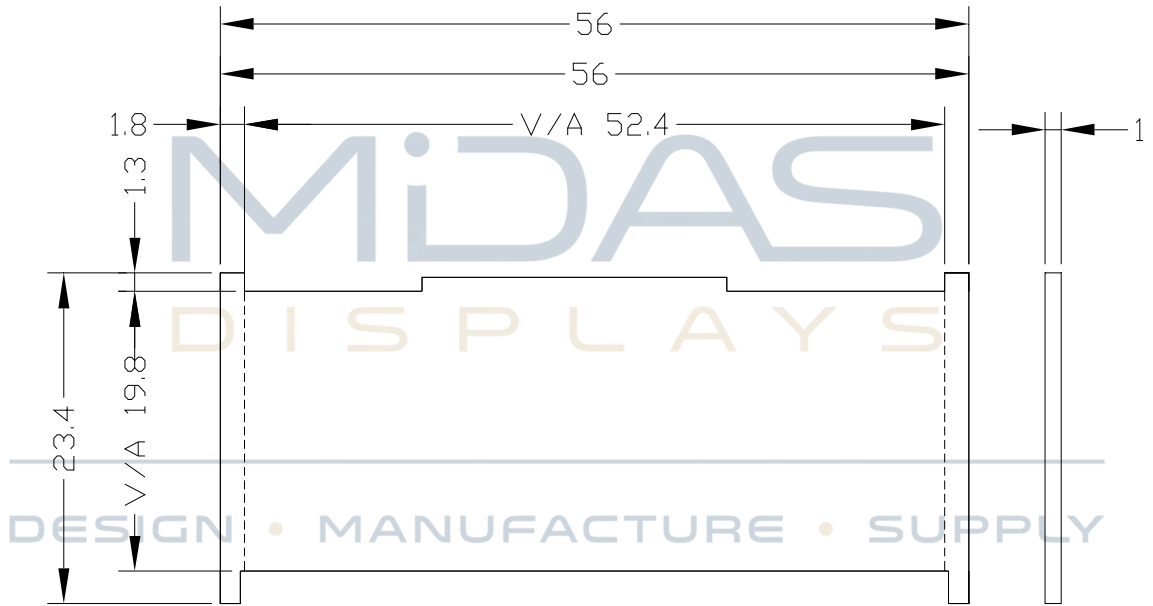

Curcuit Diagram

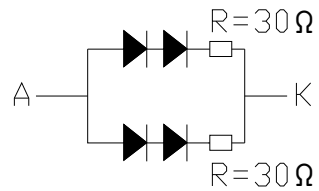

REMARKS:
 1,UNMARKED TOLERANCE IS ±0.3,
 2,COLOR: Yellow-green,
 3,THE MATERIAL COMPLY WITH ROHS.
 4,LED ON THE MODULE PCB



ABSOLUTE MAXIMUM RATINGS

PARAMETER	SYMBOL	RATING	UNIT
Supply voltage range	V_{DD}	Min.-0.3V to max.7.0V	V
Input voltage	V_{IN}	-0.3 to $V_{DD}+0.3$	V
LCD bias voltage	V_{LCD}	0 to 13	V
Operating temperature range	T_{OPR}	-20 to 70	°C
Storage temperature range	T_{STR}	-30 to 80	°C

ELECTRICAL CHARACTERISTICS

1. DC CHARACTERISTICS

ITEM	symbol	STANDARD VALUE			UNIT
		MIN	TYP	MAX	
Supply Voltage For Logic	V_{DD}	4.7	5	5.3	V
LCD Supply Voltage	V_{LCD}	4.05	4.35	4.65	
Current Consumption	I_{DD}	--	TBD	--	mA

DESIGN • MANUFACTURE • SUPPLY



2. AC CHARACTERISTICS

2-1. AC timing for interface with an 68-type microcontroller –

symbol	parameter	min.	max.	test conditons	unit
t_{AS1}	Address set-up time with respect to R/\overline{W}	20			ns
t_{AS2}	Address set-up time with respect to $\overline{C/D}, \overline{CS}$	20			ns
t_{AH1}	Address hold time with respect to R/\overline{W}	10			ns
t_{AH2}	Address hold time respect with to $\overline{C/D}, \overline{CS}$	10			ns
t_F, t_R	Enable (E) pulse falling/rising time		15		ns
t_{CYC}	System cycle time	1000		Note 1	ns
t_{EWR}	Enable pulse width for READ	100			ns
t_{EWW}	Enable pulse width for WRITE	80			ns
t_{DS}	Data setup time	80			ns
t_{DH}	Data hold time	10			ns
t_{ACC}	Data access time		90	CL= 100 pF.	ns
t_{OH}	Data output hold time	10	60	Refer to Fig. 23.	ns

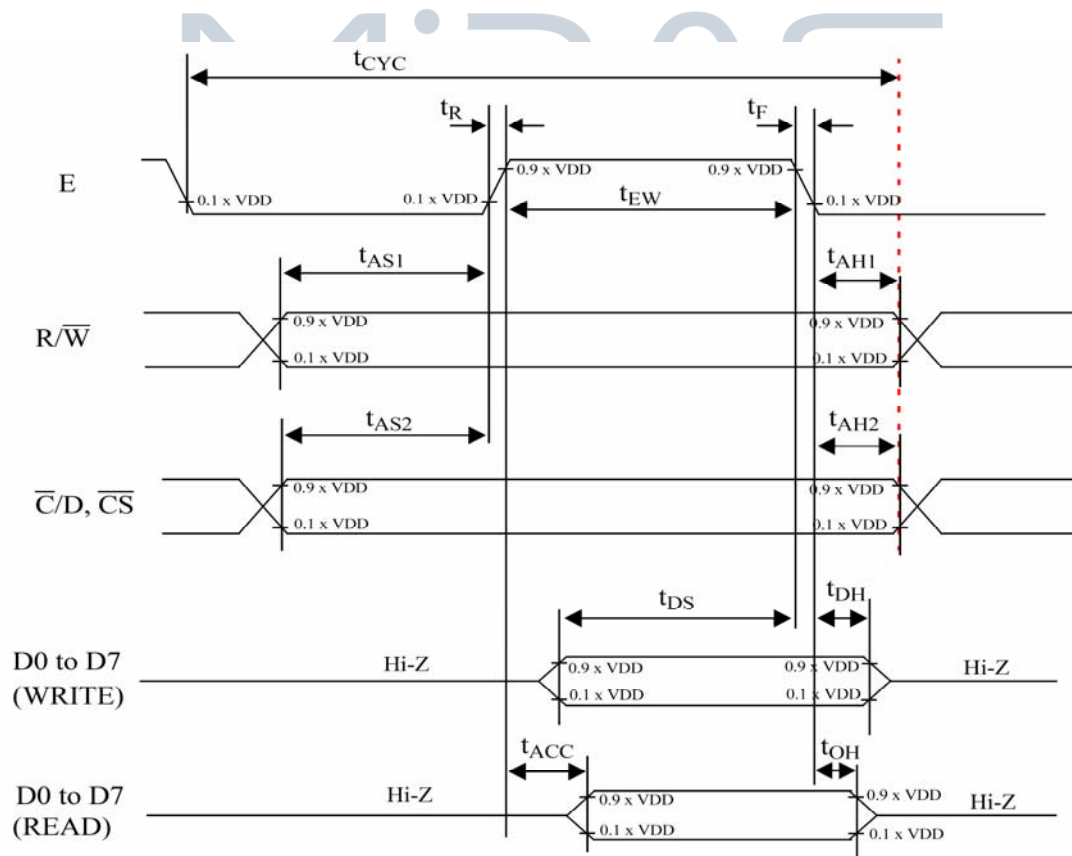

COMMANDS

The host microcontroller can issue commands to the SBN1661G_X. Table 1 lists all the commands. When issuing a command, the host microcontroller should put the command code on the data bus. The host microcontroller should also give the control bus C/D, E(RD), and R/W(WR) proper value and timing.

Commands COMMAND	. COMMAND CODE											FUNCTION
	/CS	E	W/R	DB7	DB6	DB5	DB4	DB3	DB2	DB1	DB0	
Display ON/OFF	0	1	0	1	0	1	0	1	1	1	0/1	Turns display on or off
Display start line	0	1	0	1	1	0	A4	A3	A2	A1	A0	Specifies RAM line corresponding to top line of display
Page address	0	1	0	1	0	1	1	1	0	A1	A0	Sets display RAM page in page address register
Column address	0	1	0	0	A6	A5	A4	A3	A2	A1	A0	Sets display RAM column address in column address register
Static drive ON/OFF	0	1	0	1	0	1	0	0	1	0	0/1	Selects static driving operation
Duty select	0	1	0	1	0	1	0	1	0	0	0/1	Writes/Read data select
Column/segment mapping	0	1	0	1	0	1	0	0	0	0	0/1	Selects column/segment mapping operation
Status	0	0	1	busy	mapping	on/off	reset	0	0	0	0	Shows the current state
Write Display Data	Data to be written into the Display Data Memory											Write a byte of data to the Display Data Memory.
Read Display Data	Data read from the Display Data Memory.											Read a byte of data from the Display Data Memory.
Read-Modify-Write	0	1	0	1	1	1	0	0	0	0	0	Start Read-Modify-Write operation.
END	0	1	0	1	1	1	0	1	1	1	0	Stop Read-Modify-Write operation.
Software Reset	0	1	0	1	1	1	0	0	0	1	0	Software Reset.

ACCEPT QUALITY LEVEL (AQL).

Inspection Plan: ANSI Z-1.4, Normal Inspection Level II, Single Sampling Plan.

RELIABILITY TEST

Operating life time: 50K hours

(at room temperature without direct irradiation of sunlight)

Reliability characteristics shall meet following requirements.

Test Item	Test Condition
High temperature storage	+80°C×96HR
Low temperature storage	-30°C×96HR
High temperature operation	+70°C×96HR
Low temperature operation	-20°C×96HR
High temperature, High humidity	60°C×90%RH×4 Weeks
Thermal shock	-20°C×30min → 25°C×10s → +70°C×30min ×5 Cycles
Vibration test	Frequency × Swing ×Time 40Hz×4mm×4hrs
Drop test	Height × no. of drop 1.0m×6 drops

MIDAS
DISPLAYS

DESIGN • MANUFACTURE • SUPPLY

