

MVAS. | Vertical toggle clamps

with folded base and safety stop, steel or stainless steel



- 1
- 2
- 3
- 4
- 5
- 6
- 7
- 8
- 9
- 10
- 11
- 12
- 13
- 14
- 15
- 16
- 17
- 18

STANDARD EXECUTIONS

- Open clamping lever and two folded washers:
- **MVAS-AL**: C10 zinc-plated steel, zinc-plated steel rivets.
 - **MVAS-ALX**: AISI 304 stainless steel body and rivets.
- Solid clamping lever and bolt retainer:
- **MVAS-EL**: C10 zinc-plated steel, zinc-plated steel rivets.
 - **MVAS-ELX**: AISI 304 stainless steel body and rivets.

SUPPORT BUSHINGS

Ground and hardened steel.

HANDLE

Polyurethane, red colour.

LEVER ANTI-RELEASE COVERING

Polyvinylchloride (PVC).

SPRING

AISI 302 stainless steel.

CLAMPING BOLT

To be ordered separately.

FEATURES AND APPLICATIONS

Safety stop to prevent accidental opening or closing in the presence of strong vibrations.
The operator's fingers cannot be hit by the lever while opening.
During clamping, the lever is controlled to prevent impact on functioning due to side thrust.

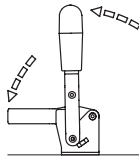

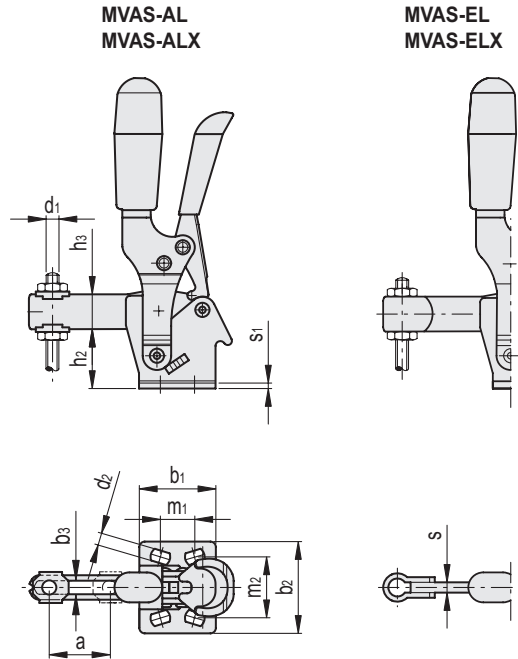
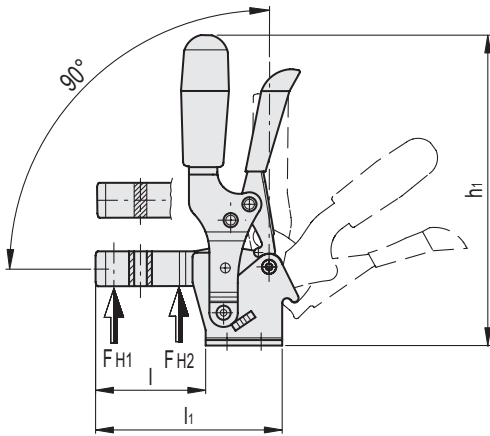

MVAS-AL

Code	Description	a	b1	b2	b3	d1	d2	h1	h2	h3	l	l1	m1	m2	s1	FH1 [N]*	FH2 [N]*	⚖
GG.AA582	MVAS.130/AL	28	35	42	6.2	M6	5.5	142	28	16	50	85	12.5+19	27+29	2.5	1050	1750	275
GG.AA590	MVAS.230/AL	40	43	45	8.5	M8	6.7	168	33.5	18	67.5	110.5	18+21	32	3	2000	3200	380

MVAS-ALX

INOX STAINLESS STEEL

Code	Description	a	b1	b2	b3	d1	d2	h1	h2	h3	l	l1	m1	m2	s1	FH1 [N]*	FH2 [N]*	⚖
GG.AS200	MVAS.130/ALX	28	35	42	6.2	M6	5.5	142	28	16	50	85	12.5+19	27+29	2.5	1050	1750	275
GG.AS210	MVAS.230/ALX	40	43	45	8.5	M8	6.7	168	33.5	18	67.5	110.5	18+21	32	3	2000	3200	380

MVAS-EL

Code	Description	b1	b2	d1	d2	h1	h2	h3	l	l1	m1	m2	s	s1	FH1 [N]*	FH2 [N]*	⚖
GG.AA586	MVAS.130/EL	35	42	M6	5.5	142	28	16	51	86	12.5+19	27+29	5	2.5	1050	1750	280
GG.AA594	MVAS.230/EL	43	45	M8	6.7	168	33.5	18	69	112	18+21	32	6	3	2000	3200	390

MVAS-ELX

INOX STAINLESS STEEL

Code	Description	b1	b2	d1	d2	h1	h2	h3	l	l1	m1	m2	s	s1	FH1 [N]*	FH2 [N]*	⚖
GG.AS204	MVAS.130/ELX	35	42	M6	5.5	142	28	16	51	86	12.5+19	27+29	5	2.5	1050	1750	280
GG.AS214	MVAS.230/ELX	43	45	M8	6.7	168	33.5	18	69	112	18+21	32	6	3	2000	3200	390

* Holding force.

