

# PN2699

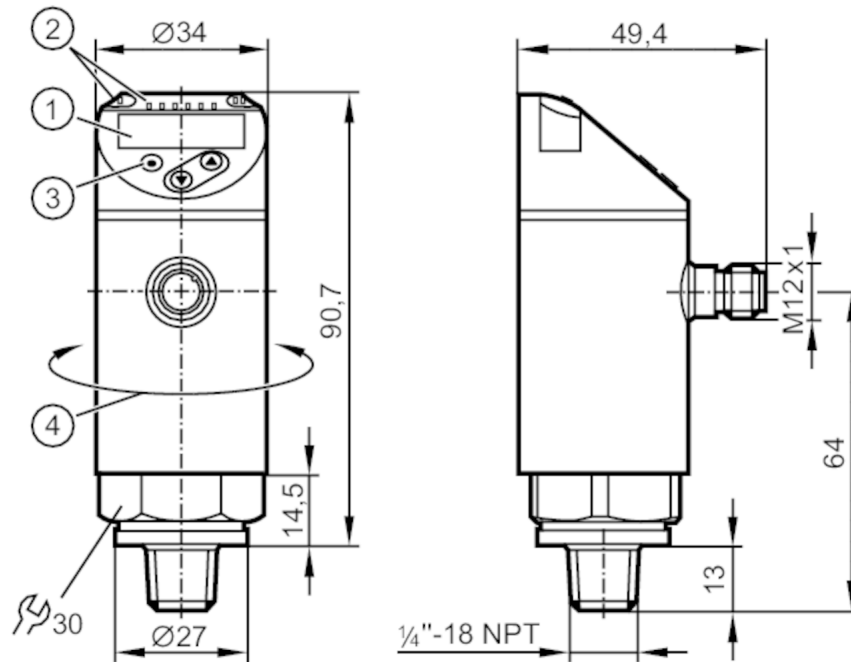

## Pressure sensor with display

PN-1-1BREN14-MFRKG/US/ IV



- 1 alphanumeric display 4-digit red/green
- 2 LEDs Display unit / switching status
- 3 programming button
- 4 upper part of the housing can be rotated 345°



### Product characteristics

Output signal	switching signal; analogue signal; IO-Link; (configurable)			
Measuring range	-1...1 bar	-1000...1000 mbar	-14.5...14.5 psi	-100...100 kPa
Process connection	threaded connection 1/4 NPT external thread			

### Application

Special feature	Gold-plated contacts			
Measuring element	ceramic-capacitive pressure measuring cell			
Application	for industrial applications			
Media	liquids and gases			
Medium temperature [°C]	-25...80			
Pressure rating	10000 mbar	145 psi	1000 kPa	
Min. bursting pressure	30000 mbar	450 psi	3000 kPa	
Vacuum resistance [mbar]	-1000			
Type of pressure	relative pressure; vacuum			
MAWP (for applications according to CRN)	20 bar	20000 mbar	290 psi	2000 kPa



## Pressure sensor with display

PN-1-1BREN14-MFRKG/US/ IV

Electrical data					
Operating voltage	[V]	18...30 DC; (according to EN 50178 SELV/PELV)			
Current consumption	[mA]	< 35			
Min. insulation resistance	[MΩ]	100; (500 V DC)			
Protection class		III			
Reverse polarity protection		yes			
Power-on delay time	[s]	0.3			
Integrated watchdog		yes			
Inputs / outputs					
Number of inputs and outputs		Number of digital outputs: 2; Number of analogue outputs: 1			
Outputs					
Total number of outputs		2			
Output signal		switching signal; analogue signal; IO-Link; (configurable)			
Electrical design		PNP/NPN			
Number of digital outputs		2			
Output function		normally open / normally closed; (parameterisable)			
Max. voltage drop switching output DC	[V]	2			
Permanent current rating of switching output DC	[mA]	250			
Switching frequency DC	[Hz]	< 500			
Number of analogue outputs		1			
Analogue current output	[mA]	4...20; (scalable 1:5)			
Max. load	[Ω]	500			
Analogue voltage output	[V]	0...10; (scalable 1:5)			
Min. load resistance	[Ω]	2000			
Short-circuit protection		yes			
Type of short-circuit protection		pulsed			
Overload protection		yes			
Measuring/setting range					
Measuring range		-1...1 bar	-1000...1000 mbar	-14.5...14.5 psi	-100...100 kPa
Set point SP		-985...1000 mbar		-14.3...14.5 psi	-98.5...100 kPa
Reset point rP		-995...990 mbar		-14.45...14.4 psi	-99.5...99 kPa
Analogue start point		-1000...600 mbar		-14.5...8.7 psi	-100...60 kPa
Analogue end point		-600...1000 mbar		-8.7...14.5 psi	-60...100 kPa
In steps of		5 mbar		0.05 psi	0.5 kPa
Accuracy / deviations					
Switch point accuracy		< ± 0,4; (Turn down 1:1)			
	[% of the span]				
Repeatability		< ± 0,1; (with temperature fluctuations < 10 K; Turn down 1:1)			
	[% of the span]				
Characteristics deviation		< ± 0,25 (BFSL) / < ± 0,5 (LS); (Turn down 1:1; BFSL = Best Fit Straight Line; LS = limit value setting)			
	[% of the span]				
Hysteresis deviation		< ± 0,1; (Turn down 1:1)			
	[% of the span]				
Long-term stability		< ± 0,05; (Turn down 1:1; per 6 months)			

# PN2699



## Pressure sensor with display

PN-1-1BREN14-MFRKG/US/ IV

	[% of the span]	
Temperature coefficient zero point	[% of the span / 10 K]	< ± 0,2; (-0...80 °C)
Temperature coefficient span	[% of the span / 10 K]	< ± 0,2; (-0...80 °C)

### Response times

Response time	[ms]	< 1.5
Delay time programmable dS, dr	[s]	0...50
Damping for the switching output dAP	[s]	0...4
Damping for the analogue output dAA	[s]	0...4
Max. response time analogue output	[ms]	3

### Software / programming

Parameter setting options	hysteresis / window; normally open / normally closed; switch-on/ switch-off delay; Damping; Display unit; current/voltage output
---------------------------	--

### Interfaces

Communication interface	IO-Link
Transmission type	COM2
IO-Link revision	1.1
SDCI standard	IEC 61131-9
IO-Link device ID	477 d / 00 01 dd h
Profiles	Smart Sensor: Process Data Variable; Device Identification, Device Diagnosis
SIO mode	yes
Required master port type	A
Process data analogue	1
Process data binary	2
Min. process cycle time	[ms] 2.3

### Operating conditions

Ambient temperature	[°C]	-25...80
Storage temperature	[°C]	-40...100
Protection		IP 65; IP 67

### Tests / approvals

EMC	DIN EN 61000-6-2	
	DIN EN 61000-6-3	
Shock resistance	DIN EN 60068-2-27	50 g (11 ms)
Vibration resistance	DIN EN 60068-2-6	20 g (10...2000 Hz)
MTTF	[years]	138
UL approval	UL Approval no.	J012
Pressure Equipment Directive	Sound engineering practice; can be used for group 2 fluids; group 1 fluids on request	

# PN2699



## Pressure sensor with display

PN-1-1BREN14-MFRKG/US/ IV

Mechanical data	
Weight [g]	246
Materials	stainless steel (1.4404 / 316L); PBT+PC-GF30; PBT-GF20; PC
Materials (wetted parts)	stainless steel (1.4404 / 316L); Al <sub>2</sub> O <sub>3</sub> (96%; ceramics); FKM
Min. pressure cycles	100 million
Tightening torque [Nm]	> 50; (depends on lubrication, seal and pressure rating)
Process connection	threaded connection 1/4 NPT external thread
Restrictor element integrated	no (can be retrofitted)

Displays / operating elements		
Display	Display unit	5 x LED, green (mbar, psi, kPa, inH <sub>2</sub> O, inHg)
	switching status	2 x LED, yellow
	measured values	alphanumeric display, red/green 4-digit

Remarks	
Pack quantity	1 pcs.

### Electrical connection

Connector: 1 x M12; Contacts: gold-plated



# PN2699



## Pressure sensor with display

PN-1-1BREN14-MFRKG/US/ IV

### Connection



OUT1            switching output

OUT2            switching output

analogue output

Core colours :

BK =            black

BN =            brown

BU =            blue

WH =            white