



DC/DC CONVERTER

- 24V DC Input
- Quick-connect Spring-clamp Connection Terminals
- Isolated 24Vdc Output
- Efficiency up to 90.2%
- Width only 32mm
- 20% Output Power Reserves
- Full Power Between -25°C and +60°C
- Soft-start Function Included
- Minimal Inrush Current Surge
- Reverse Input Polarity Protection
- DC-OK and Input-low Relay Contact
- 3 Year Warranty

PRODUCT DESCRIPTION

The Dimension CD-Series offer DIN rail DC/DC converters in the 92-120W output power range in a very compact housing. These DC/DC converters are allowed to run with a battery or similar sources or can also be used to refresh and stabilize the 24Vdc on the end of long cable runs. The basic units include all the essential basic functions while the -S1 version is equipped with quick-connect spring clamp terminals, a DC-OK contact which monitors the output and an input-low-relay-contact. The -L1 version additionally fulfills the NEC Class 2 requirements. All devices except the CD5.241-L1 have a PowerBoost of 20% incorporated. This extra power can even be used continuously up to +45°C.

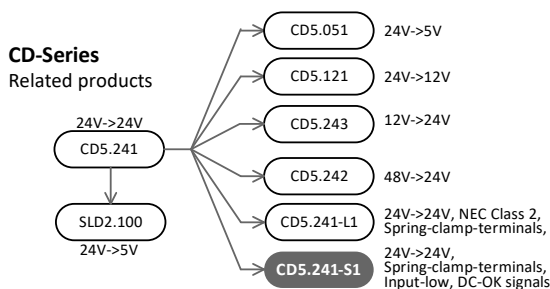

SHORT-FORM DATA

Output voltage	DC 24V	
Adjustment range	24 - 28V	*)
Output current	5 – 4.3A	ambient <60°C
	6 – 5.2A	ambient <45°C
Output power	120W	ambient <60°C
	144W	ambient <45°C
Output ripple	< 50mVpp	20Hz to 20MHz
Input voltage	DC 24V	
Input voltage range	18 to 32.4Vdc	full specified
	14.4 to 18Vdc	with derating
Input current	typ. 5.5A	at 24Vdc input
Input inrush current	typ. 1.2A peak	
Efficiency	90.2%	at 24Vdc input
Losses	13.3W	at 24Vdc input
Temperature range	-25°C to +70°C	operational
Derating	3W/°C	+60 to +70°C
Hold-up time	typ. 6ms	at 24Vdc input
Dimensions	32x124x102mm	WxHxD
Weight	450g / 0.99lb	

*) extended guaranteed adjustment range down to 23V.

ORDER NUMBERS

DC/DC Converter	CD5.241-S1	Standard unit
Accessory	ZM1.WALL	Wall mount bracket
	ZM10.WALL	Wall mount bracket
	ZM11.SIDE	Side mount bracket
	YR2.DIODE	Redundancy module

MAIN APPROVAL

For details and the complete approval list, see chapter 20



UL 508



ATEX



UL 60950-1



Marine



Class I Div 2



Marine

INDEX

	Page		Page
1. Intended Use	3	22. Physical Dimensions and Weight.....	20
2. Installation Instructions	3	23. Accessories	21
3. Input Voltage	5	23.1. ZM1.WALL - Wall mounting bracket	21
4. Soft-start and Input Inrush Current Surge	6	23.2. ZM10.WALL - Wall/Panel Mount Bracket	21
5. Output	7	23.3. ZM11.SIDE - Side mounting bracket	22
6. Hold-up Time.....	8	23.4. YR2.DIODE Redundancy Module	22
7. Efficiency and Power Losses.....	9	24. Application Notes	23
8. Functional Diagram.....	10	24.1. Peak Current Capability	23
9. Front Side and User Elements.....	10	24.2. Back-feeding Loads	23
10. Terminals and Wiring.....	11	24.3. Inductive and Capacitive Loads.....	23
11. Lifetime Expectancy	12	24.4. Charging of Batteries	24
12. MTBF.....	12	24.5. External Input Protection.....	24
13. DC-OK Relay Contact	13	24.6. Requirements for the Supplying Source.....	24
14. Input-low Relay Contact	13	24.7. Parallel Use to Increase Output Power	25
15. EMC	14	24.8. Parallel Use for Redundancy	25
16. Environment.....	15	24.9. Daisy Chaining of Outputs	26
17. Protection Features.....	16	24.10. Series Operation	26
18. Safety Features.....	16	24.11. Use in a Tightly Sealed Enclosure	26
19. Dielectric Strength	17	24.12. Mounting Orientations	27
20. Approved, Fulfilled or Tested Standards.....	18		
21. Regulatory Product Compliance.....	19		

The information presented in this document is believed to be accurate and reliable and may change without notice. Some parts of this unit are patent by PULS (US patent No 091662,063, Des. 424,529, ...).

No part of this document may be reproduced or utilized in any form without permission in writing from PULS GmbH.

TERMINOLOGY AND ABBREVIATIONS

PE and \oplus symbol	PE is the abbreviation for Protective Earth and has the same meaning as the symbol \oplus .
Earth, Ground	This document uses the term "earth" which is the same as the U.S. term "ground".
T.b.d.	To be defined, value or description will follow later.
DC 24V	A figure displayed with the AC or DC before the value represents a nominal voltage with standard tolerances included. E.g.: DC 12V describes a 12V battery disregarding whether it is full (13.7V) or flat (10V)
24Vdc	A figure with the unit (Vac) at the end is a momentary figure without any additional tolerances included.

1. INTENDED USE

This device is designed for installation in an enclosure and is intended for commercial use, such as in industrial control, process control, monitoring and measurement equipment or the like. Do not use this device in equipment where malfunction may cause severe personal injury or threaten human life.

If this device is used in a manner outside of its specification, the protection provided by the device may be impaired.

2. INSTALLATION INSTRUCTIONS

WARNING Risk of electrical shock, fire, personal injury or death.

- Turn power off before working on the device and protect against inadvertent re-powering.
- Do not open, modify or repair the device.
- Use caution to prevent any foreign objects from entering into the housing.
- Do not use in wet locations or in areas where moisture or condensation can be expected.
- Do not touch during power-on, and immediately after power-off. Hot surface may cause burns.

Obey the following installation instructions:

This device may only be installed and put into operation by qualified personnel.

This device does not contain serviceable parts. The tripping of an internal fuse is caused by an internal defect.

If damage or malfunction should occur during installation or operation, immediately turn power off and send unit to the factory for inspection.

Install device in an enclosure providing protection against electrical, mechanical and fire hazards.

Install the device onto a DIN rail according to EN 60715 with the input terminals on the bottom of the device. Other mounting orientations require a reduction in output current.

Make sure that the wiring is correct by following all local and national codes. Use appropriate copper cables that are designed for a minimum operating temperature of 60°C for ambient temperatures up to +45°C, 75°C for ambient temperatures up to +60°C and 90°C for ambient temperatures up to +70°C.

Ensure that all strands of a stranded wire enter the terminal connection. Unused screw terminals should be securely tightened.

The device is designed for pollution degree 2 areas in controlled environments. No condensation or frost is allowed.

The enclosure of the device provides a degree of protection of IP20. The enclosure does not provide protection against spilled liquids.

The isolation of the device is designed to withstand impulse voltages of 1.5kV according to IEC 60664-1.

The input can be powered from batteries or similar DC sources. The voltage between the input terminals and ground must not exceed 60Vdc continuously. The ripple voltage in the low frequency range between 50Hz and 10kHz must be negligible when used in marine applications.

The input must be powered from a PELV or SELV source or an "Isolated Secondary Circuit" in order to maintain a SELV or PELV output.

Check for correct input polarity. The device will not operate when the voltage is reversed.

A disconnecting means shall be provided for the input of the device.

The device is designed as "Class of Protection III" equipment according to IEC 61140. A PE (ground) connection is not required. However, connecting the chassis ground terminal to ground can be beneficial to gain a high EMI immunity.

The device is designed for convection cooling and does not require an external fan. Do not obstruct airflow and do not cover ventilation grid!

The device is designed for altitudes up to 5000m (16400ft). Above 2000m (6560ft) a reduction in output current is required.

Keep the following minimum installation clearances: 40mm on top, 20mm on the bottom, 5mm left and right side. Increase the 5mm to 15mm in case the adjacent device is a heat source. When the device is permanently loaded with less than 50%, the 5mm can be reduced to zero.

The device is designed, tested and approved for branch circuits up to 50A without additional protection device. If an external fuse is utilized, do not use circuit breakers smaller than 10A B- or 8A C-Characteristic to avoid a nuisance tripping of the circuit breaker.

The maximum surrounding air temperature is +70°C (+158°F). The operational temperature is the same as the ambient or surrounding air temperature and is defined 2cm below the device.

The device is designed to operate in areas between 5% and 95% relative humidity.

Installation Instructions for Hazardous Location Areas

The device is suitable for use in Class I Division 2 Groups A, B, C, D locations and for use in Group II Category 3 (Zone 2) environments.

Classification: ATEX: EPS 08 ATEX 1 142 X, II 3G EX ec nC IIC T4 Gc / IECEx EPS 14.0001X

WARNING EXPLOSION HAZARDS!

Substitution of components may impair suitability for this environment.

Do not disconnect the device or operate the voltage adjustment unless power has been switched off or the area is known to be non-hazardous.

A suitable enclosure must be provided for the end product which has a minimum protection of IP54 and fulfils the requirements of the EN 60079-0.

Reduced output current conditions must be considered for high ambient temperatures and non-standard mounting orientations.

3. INPUT VOLTAGE

Input voltage	nom.	DC 24V	
Input voltage range		18.0-32.4Vdc	full specified
		14.4-18.0Vdc	maximal 60 seconds or with de-rating see Fig. 3-2
	max.	36.0Vdc	absolute maximum continuous input voltage with no damage to the DC/DC converter
Allowed voltage between input and earth	max.	60Vdc or 42.2Vac	in case the output voltage is not grounded.
Allowed input ripple voltage	max.	5Vpp	47Hz-500Hz, the momentary input voltage must always be within the specified limits.
Turn-on voltage	typ.	17.5Vdc	steady-state value, see Fig. 3-1
Shut-down voltage	typ.	14.0Vdc	steady-state value, see Fig. 3-1
	typ.	35.0Vdc	steady-state value, see Fig. 3-1
Input current	typ.	5.5A	at 24Vdc input and output 24V, 5A, see Fig. 3-4
Start-up delay	typ.	650ms	see Fig. 3-3
Rise time	typ.	80ms	0mF, 24V, constant current load 5A, see Fig. 3-3
	typ.	150ms	5mF, 24V, constant current load 5A, see Fig. 3-3
Turn-on overshoot	max.	500mV	see Fig. 3-3
Input capacitance	typ.	3 000µF	external capacitors on the input voltage bus are allowed without any limitations.

Fig. 3-1 **Input voltage range**

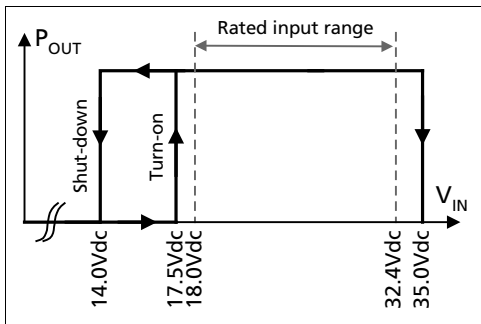

Fig. 3-2 **Allowable output current below 18V input voltage**

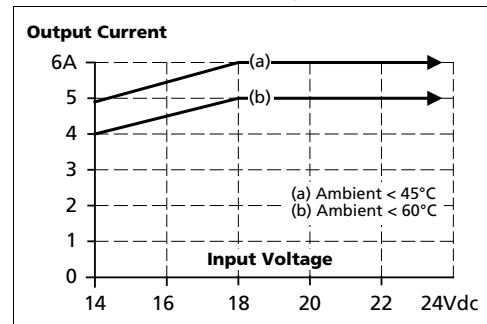

Fig. 3-3 **Turn-on behavior, definitions**

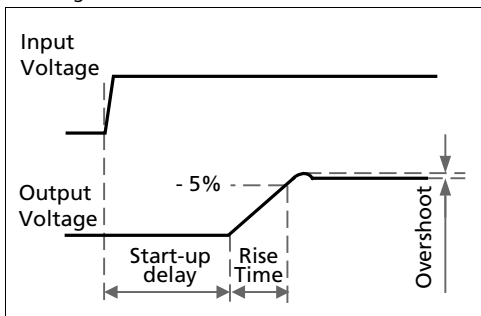
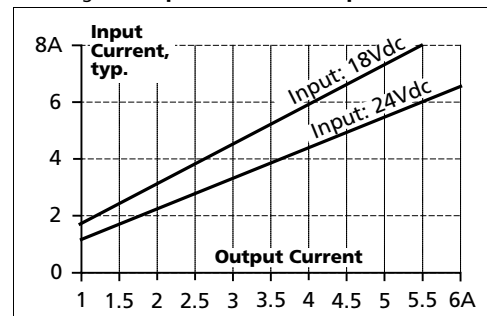

Fig. 3-4 **Input current vs. output load**



4. SOFT-START AND INPUT INRUSH CURRENT SURGE

Inrush current limitation

An active inrush limitation circuit (inrush limiting resistor which is bypassed by a relay contact) limits the input inrush current after turn-on of the input voltage.

The charging current into EMI suppression capacitors is disregarded in the first microseconds after switch-on.

Inrush current	max.	1.6A _{peak}	-25°C to +70°C, input: 24Vdc
	typ.	1.2A _{peak}	-25°C to +70°C, input: 24Vdc
Inrush energy	typ.	negligible	-25°C to +70°C, input: 24Vdc

Fig. 4-1 Input inrush current, typical behavior

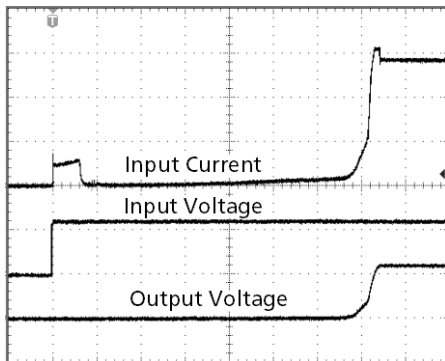

Input: 24Vdc
 Output: 24V, 5A, constant current load
 Ambient: 25°C

Upper curve: Input current 2A / DIV
 Middle curve: Input voltage 20V / DIV
 Lower curve: Output voltage 20V / DIV
 Time basis: 100ms / DIV

Soft-start function:

After the DC/DC converter is turned on, the internal output current rises slowly to its nominal value. This method charges the output capacitors (internal and external capacitors) slowly and avoids high input currents during turn-on. High input currents can produce a high voltage drop on the input wiring (especially with long and thin cables) which reduces the terminal voltage on the DC/DC converter. If the terminal voltage is below the shut-down voltage, the DC/DC converter will turn-off and will make a new start-up attempt. This effect is avoided with the integrated soft-start function. Please note, that this function increases the rise time of the output voltage by a small amount.

Fig. 4-2 Soft-start behavior

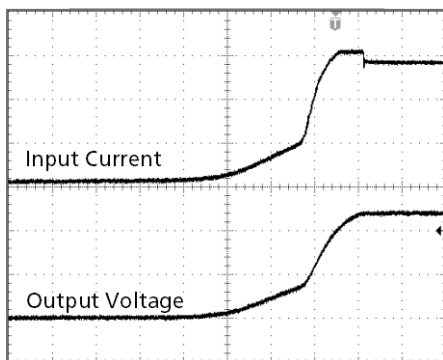

Input: 24Vdc
 Output: 24V, 5A, constant current load
 Ambient: 25°C
 No additional external output capacitors

Upper curve: Input current 2A / DIV
 Lower curve: Output voltage 10V / DIV
 Time basis: 20ms / DIV

5. OUTPUT

Output voltage	nom.	24V	
Adjustment range		24-28V	*)
	max.	30V	at clockwise end position of potentiometer
Factory setting		24.1V	±0.2%, at full load, cold unit
Line regulation	max.	25mV	Input voltage variations between 18 to 32.4Vdc
Load regulation	max.	150mV	static value, 0A → 5A
Ripple and noise voltage	max.	50mVpp	20Hz to 20MHz, 50Ohm
Output capacitance	typ.	2 200µF	
Output current	nom.	6A	at 24V, ambient < 45°C, see Fig. 5-1
	nom.	5A	at 24V, ambient < 60°C, see Fig. 5-1
	nom.	5.2A	at 28V, ambient < 45°C, see Fig. 5-1
	nom.	4.3A	at 28V, ambient < 60°C, see Fig. 5-1
Output power	nom.	144W	for ambient temperatures < 45°C
	nom.	120W	for ambient temperatures < 60°C
Short-circuit current	min.	7A	continuous current, short circuit impedance 200mOhm
	max.	10A	continuous current, short circuit impedance 200mOhm

*) extended guaranteed adjustment range down to 23V.

Fig. 5-1 **Output voltage vs. output current at 24Vdc input voltage, typ.**

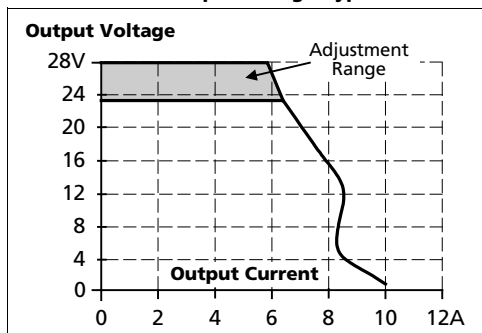
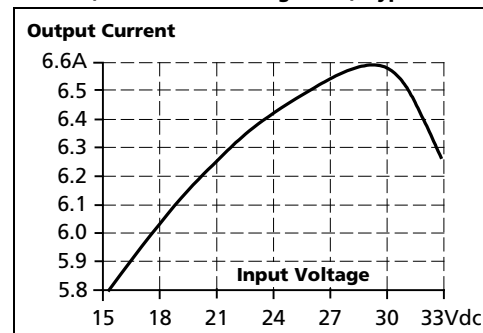

Fig. 5-2 **Current limitation vs. input voltage, (23V constant voltage load), typ.**



Peak current capability (up to several milliseconds)

The DC/DC converter can deliver a peak current, which is higher than the specified short term current. This helps to start current demanding loads or to safely operate subsequent circuit breakers.

The extra current is supplied by the output capacitors inside the DC/DC converter. During this event, the capacitors will be discharged and causes a voltage dip on the output. Detailed curves can be found in chapter 24.1.

Peak current voltage dips	typ.	from 24V to 18V	at 10A for 50ms, resistive load
	typ.	from 24V to 15V	at 20A for 2ms, resistive load
	typ.	from 24V to 11.5V	at 20A for 5ms, resistive load

6. HOLD-UP TIME

The input side of the DC/DC converter is equipped with a bulk capacitor which keeps the output voltage alive for a certain period of time when the input voltage dips or is removed. The bulk capacitor can be discharged by loading the DC/DC converter on the output side or through a load which is parallel to the input. There is no protection in the DC/DC converter which prevents current from flowing back to the input terminals. If prevention is needed, an external diode should be used.

Hold-up Time	typ.	11.8ms	input 24Vdc, output: 24Vdc, 2.5A, see Fig. 6-1
	typ.	6ms	input 24Vdc, output: 24Vdc, 5A, see Fig. 6-1

Fig. 6-1 Hold-up time vs. input voltage

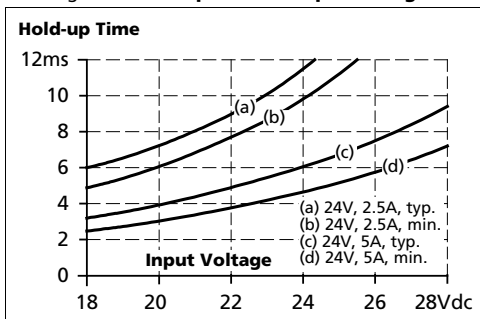

Fig. 6-2 Shut-down test setup

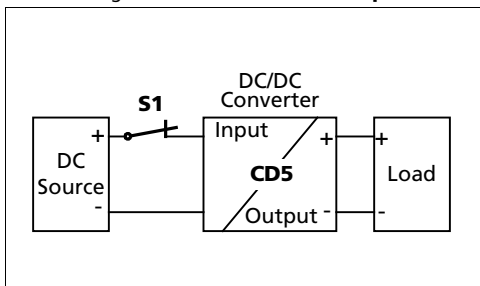
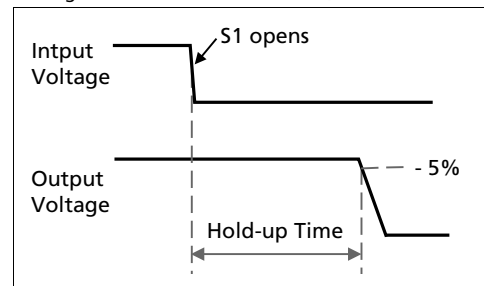

Fig. 6-3 Shut-down behavior, definitions



Note: At no load, the hold-up time can be up to several seconds. The green DC-OK LED is also on during this time.

7. EFFICIENCY AND POWER LOSSES

Input 24Vdc			
Efficiency	typ.	90.2%	at 24V, 5A
Power losses	typ.	1.1W	at no output load
	typ.	6.6W	at 24V, 2.5A
	typ.	13.3W	at 24V, 5A
	typ.	16.7W	at 24V, 6A

Fig. 7-1 Efficiency vs. output current at 24V, typ.

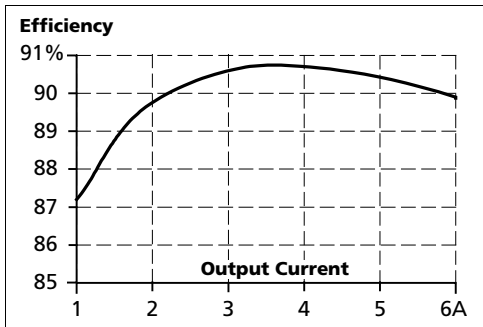

Fig. 7-2 Losses vs. output current at 24V, typ.

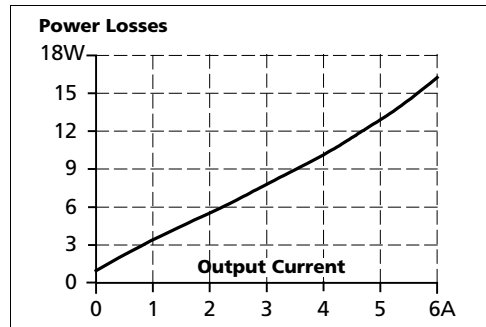

Fig. 7-3 Efficiency vs. input voltage at 24V, 5A, typ.

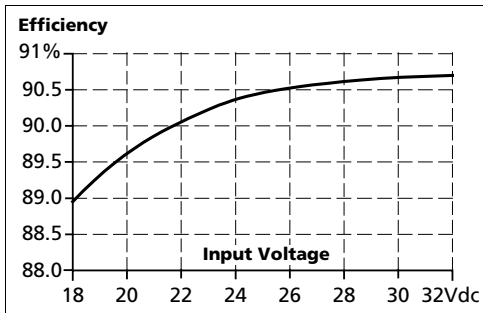
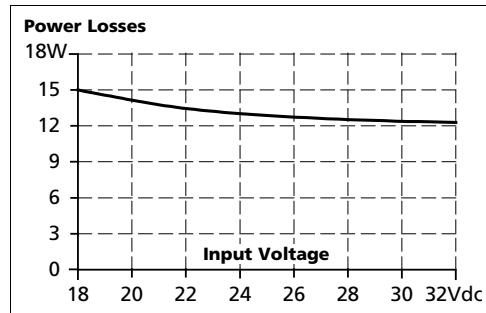
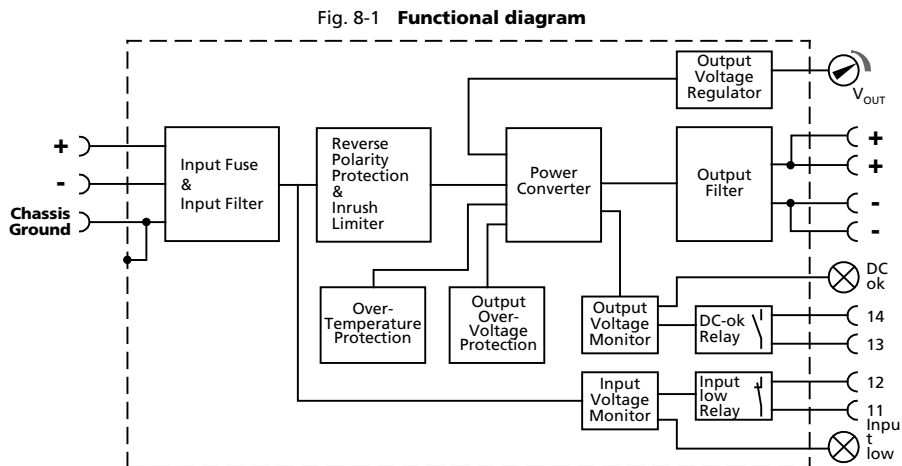

Fig. 7-4 Losses vs. input voltage at 24V, 5A, typ.



8. FUNCTIONAL DIAGRAM



9. FRONT SIDE AND USER ELEMENTS

Fig. 9-1 Front side



- A** Input terminals
Screw terminals
+ Positive input
- Negative (return) input
Chassis ground: can be used to bond the housing to PE
Ground this terminal to minimize high-frequency emissions.
- B** Output terminals
Screw terminals, dual terminals per pole, both pins are equal
+ Positive output
- Negative (return) output
- C** Output voltage potentiometer
Open the flap to set the output voltage. Factory set: 24.1V
- D** DC-OK LED (green)
Monitors the output voltage, which is produced by the DC/DC converter itself and is on when the voltage is higher than 90% of the adjusted output voltage.
DC-OK LED and DC-OK contact functions are synchronized
- E** Signal terminals
Plug Connector for DC-OK and Input-low relay contact
- F** Input-low LED (yellow) see also chapter 14.
On when the input voltage is between 4Vdc and 20Vdc.
Input-low LED and Input-low contact functions are synchronized.

10. TERMINALS AND WIRING

	Input	Output	DC-OK and Input-low Signal
Type	spring-clamp terminals	spring-clamp terminals	Plug-connector, screw type
Solid wire	max. 6mm ²	max. 6mm ²	max. 1.5mm ²
Stranded wire	max. 4mm ²	max. 4mm ²	max. 1.5mm ²
American Wire Gauge	20-10 AWG	20-10 AWG	22-14 AWG
Wire stripping length	10mm / 0.4inch	10mm / 0.4inch	6mm / 0.25inch
Screwdriver	not applicable	not applicable	3.5mm slotted or Pozidrive No 2
Recommended tightening torque	not applicable	not applicable	0.4Nm, 3.5lb.in

Instructions:

- a) The external circuitry of all terminals (including signalling contacts) must meet the safety requirements stipulated by IEC/EN/UL 60950-1: SELV.
- b) Use appropriate copper cables that are designed for an operating temperature of:
60°C for ambient up to 45°C and
75°C for ambient up to 60°C minimum.
- c) Follow national installation codes and installation regulations!
- d) Ensure that all strands of a stranded wire enter the terminal connection!
- e) Do not load the terminals with more than 25A! See section 24.9
- f) Screws of unused terminal compartments should be securely tightened.
- g) Ferrules are allowed.
- h) Do not connect or disconnect the wires from the terminals below -25°C (-13°F).

11. LIFETIME EXPECTANCY

The Lifetime expectancy shown in the table indicates the minimum operating hours (service life) and is determined by the lifetime expectancy of the built-in electrolytic capacitors. Lifetime expectancy is specified in operational hours and is calculated according to the capacitor's manufacturer specification. The prediction model allows only a calculation of up to 15 years from date of shipment.

	Input 24Vdc	
Lifetime expectancy	180 000h	at 24V, 2.5A and 40°C
	60 000h	at 24V, 5A and 40°C
	33 000h	at 24V, 6A and 40°C
	169 000h	at 24V, 5A and 25°C

12. MTBF

MTBF stands for **Mean Time Between Failure**, which is calculated according to statistical device failures, and indicates reliability of a device. It is the statistical representation of the likelihood of a unit to fail and does not necessarily represent the life of a product.

The MTBF figure is a statistical representation of the likelihood of a device to fail. A MTBF figure of e.g. 1 000 000h means that statistically one unit will fail every 100 hours if 10 000 units are installed in the field. However, it can not be determined if the failed unit has been running for 50 000h or only for 100h.

	Input 24Vdc	
MTBF SN 29500, IEC 61709	1 048 000h	at 24V, 5A and 40°C
	1 719 000h	at 24V, 5A and 25°C
MTBF MIL HDBK 217F	602 000h	at 24V, 5A and 40°C; Ground Benign GB40
	807 000h	at 24V, 5A and 25°C; Ground Benign GB25

13. DC-OK RELAY CONTACT

This feature is only available on the model CD5.241-S1 and monitors the output voltage, which is produced by the DC/DC converter itself. It is independent of a back-fed voltage from a unit which is connected in parallel to the DC/DC converter output. It is a "Normally Open" contact.

Contact closes	As soon as the output voltage reaches the adjusted output voltage.
Contact opens	As soon as the output voltage dips more than 10% below the adjusted output voltage. Short dips will be extended to a signal length of 250ms. Dips shorter than 1ms will be ignored.
Contact re-closes	As soon as the output voltage exceeds 90% of the adjusted voltage.
Contact ratings	max 60Vdc 0.3A, 30Vdc 1A, 30Vac 0.5A, resistive load min 1mA at 5Vdc (minimum permissible load)
Isolation voltage	See dielectric strength table in section 19.

Note:

The DC-OK feature requires that the output voltage reaches the nominal (=adjusted) level after turn-on in order to function according to specification. If this level cannot be achieved, the overload LED will be on and the DC-OK contact will be open. The overload signal will only shut off as soon as the adjusted voltage is reached. This is an important condition to consider particularly, if the load is a battery, the DC/DC converter is used in parallel or the DC/DC converter is used for N+1 redundant systems.

Fig. 13-1 DC-OK relay contact behavior

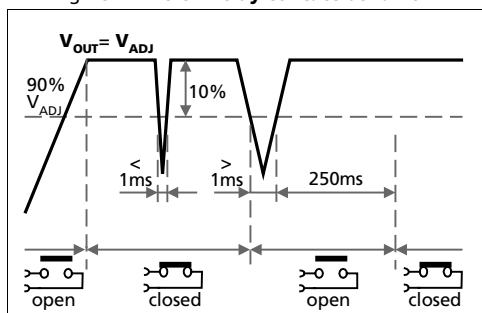

14. INPUT-LOW RELAY CONTACT

This feature monitors the input voltage of the DC/DC converter. It is a "Normally Closed" contact. It can be used to get an alarm signal when the supplying battery becomes flat (under-voltage logout)

Contact is closed	When the input voltage falls below 19.5Vdc (typ.)
Contact opens	As soon as the input voltage reaches 20.5 Vdc (typ.)
Contact ratings	max 60Vdc 0.3A, 30Vdc 1A, 30Vac 0.5A, resistive load min 1mA at 5Vdc (minimum permissible load)
Isolation voltage	See dielectric strength table in chapter 19.

15. EMC

The DC/DC converter is suitable for applications in industrial environment as well as in residential, commercial and light industry environment without any restrictions.

EMC Immunity		Generic standards: EN 61000-6-1 and EN 61000-6-2		
Electrostatic discharge	EN 61000-4-2	Contact discharge	8kV	Criterion A
		Air discharge	15kV	Criterion A
Electromagnetic RF field	EN 61000-4-3	80MHz-2.7GHz	10V/m	Criterion A
Fast transients (Burst)	EN 61000-4-4	Input lines	4kV	Criterion A
		Output lines	2kV	Criterion A
		Signal lines	2kV	Criterion A
Surge voltage on input	EN 61000-4-5	+ → -	1kV	Criterion A
		+/- → chassis ground	2kV	Criterion A
Surge voltage on output	EN 61000-4-5	+ → -	500V	Criterion A
		+ / - → chassis ground	1kV	Criterion A
Conducted disturbance	EN 61000-4-6	0.15-80MHz	10V	Criterion A

Criteria:

- A:** DC/DC converter shows normal operation behavior within the defined limits.
- C:** Temporary loss of function is possible. DC/DC converter may shut-down and restarts by itself. No damage or hazards for the DC/DC converter will occur.

EMC Emission		Generic standards: EN 61000-6-3 and EN 61000-6-4	
Conducted emission on input	IEC/CISPR 16-1-2, IEC/CISPR 16-2-1	Limits for DC power ports acc. EN 61000-6-3 fulfilled	
Radiated emission	EN 55011, EN 55032	Class B	

This device complies with FCC Part 15 rules.

Operation is subjected to following two conditions: (1) this device may not cause harmful interference, and (2) this device must accept any interference received, including interference that may cause undesired operation.

Switching frequency

Variable between 90kHz and 135kHz depending on load and input voltage (output current > 0.5A)

16. ENVIRONMENT

Operational temperature *)	-25°C to +70°C (-13°F to 158°F)	Reduce output power according Fig. 16-1
Storage temperature	-40 to +85°C (-40°F to 185°F)	For storage and transportation
Output de-rating	1.6W/°C 3W/°C	45-60°C (113°F to 140°F) 60-70°C (140°F to 158°F)
Humidity **)	5 to 95% r.H.	IEC 60068-2-30
Vibration sinusoidal ***)	2-17.8Hz: ±1.6mm; 17.8-500Hz: 2g 2 hours / axis	IEC 60068-2-6
Shock ****)	30g 6ms, 20g 11ms 3 bumps / direction, 18 bumps in total	IEC 60068-2-27
Altitude	0 to 6000m (0 to 20 000ft)	Reduce output power or ambient temperature above 2000m sea level.
Altitude de-rating	7.5W/1000m or 5°C/1000m	above 2000m (6500ft), see Fig. 16-2
Over-voltage category	III II	IEC 62477-1, EN 50178, altitudes up to 2000m Altitudes from 2000m to 6000m
Degree of pollution	2	IEC 62477-1, EN 50178, not conductive

*) Operational temperature is the same as the ambient temperature and is defined as the air temperature 2cm below the unit.

***) Do not energize while condensation is present

****) Tested in combination with DIN rails according to EN 60715 with a height of 15mm and a thickness of 1.3mm and standard mounting orientation.

Fig. 16-1 Output current vs. ambient temp.

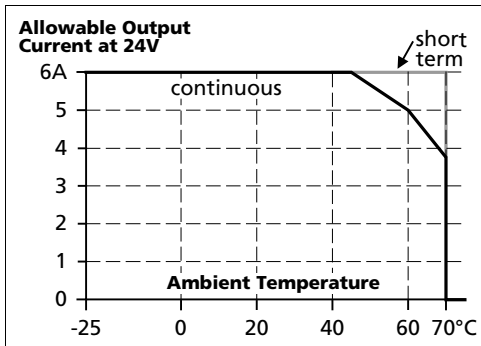
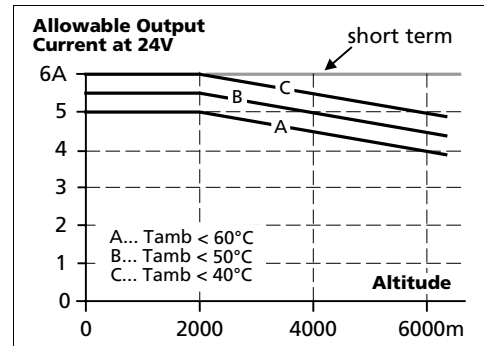

Fig. 16-2 Output current vs. altitude at 24V



17. PROTECTION FEATURES

Output protection	Electronically protected against overload, no-load and short-circuits *)	
Output over-voltage protection	typ. 31Vdc max. 32Vdc	in case of an internal power supply defect, a redundant circuit limits the maximum output voltage. The output shuts down and automatically attempts to restart.
Reverse input polarity protection	Included	unit does not start when input voltage is reversed
Output over-current protection	electronically limited *)	see Fig. 5-1
Degree of protection	IP 20	EN/IEC 60529
Penetration protection	> 3.5mm	e.g. screws, small parts
Over-temperature protection	yes	output shut-down with automatic restart
Input transient protection	MOV	Metal Oxide Varistor
Internal input fuse	included	not user replaceable

*) In case of a protection event, audible noise may occur.

18. SAFETY FEATURES

Classification of output voltage	SELV PELV	IEC/EN 60950-1 IEC/EN 60204-1, EN 50178, IEC 62477-1, IEC 60364-4-41
Class of protection	III	PE (Protective Earth) connection not required. A connection of the "Chassis Ground" pin to earth is recommended for best EMI performance
Isolation resistance	> 5M Ω	input to output, 500Vdc
PE resistance	< 0.1 Ω	between housing and Chassis Ground terminal
Touch current (leakage current)	The leakage current which is produced by the DC/DC converter itself depends on the input voltage ripple and need to be investigated in the final application. For a smooth DC input voltage, the produced leakage current is less than 100 μ A.	

*) provided, that the input voltage meets the requirements of chapter 2.

19. DIELECTRIC STRENGTH

The output voltage is floating and has no ohmic connection to the ground.

Type and factory tests are conducted by the manufacturer. Field tests may be conducted in the field using the appropriate test equipment which applies the voltage with a slow ramp (2s up and 2s down). Connect all input terminals together as well as all output poles before conducting the test. When testing, set the cut-off current settings to the value in the table below.



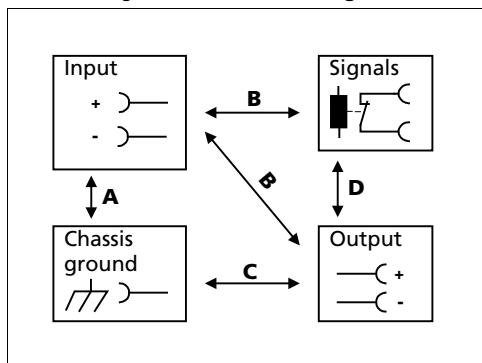



Fig. 19-1 Dielectric strength



		A	B	C	D
Type test	60s	1500Vac	1000Vac	500Vac	500Vac
Factory test	5s	1500Vac	1000Vac	500Vac	500Vac
Field test	5s	1000Vac	1000Vac	500Vac	500Vac
Cut-off current setting		> 30mA	> 30mA	> 12mA	> 1mA



To fulfill the PELV requirements according to EN60204-1 § 6.4.1, we recommend that either the + pole, the - pole or any other part of the output circuit shall be connected to the protective earth system. This helps to avoid situations in which a load starts unexpectedly or can not be switched off when unnoticed earth faults occur.

20. APPROVED, FULFILLED OR TESTED STANDARDS

UL 508		UL Certificate Listed equipment for category NMTR - Industrial Control Equipment Applicable for US and Canada E-File: E198865
IEC 61010-1	CB Report	CB Scheme Certificate Safety requirements for electrical equipment for measurement, control and laboratory use - General requirements
UL 61010-1		UL Certificate Recognized component for category QQHC - Safety Requirements for Electrical Equipment for Measurement, Control, and Laboratory Use - General Requirements Applicable for US and Canada E-File: E326782
IEC 60950-1	CB Report	CB Scheme Certificate General safety requirements for Information Technology Equipment (ITE)
UL 60950-1		UL Certificate Recognized component for category QQGQ - Information Technology Equipment (ITE) Applicable for US and Canada E-File: E137006
ATEX		Agency Certificate (Bureau Veritas) EN 60079-0 Explosive atmospheres - General requirements EN 60079-7, EN 60079-15 Equipment protection by type of protection "e" and "n" Certificate: EPS 08 ATEX 1 142 X Temperature Code: T4 Type of Protection: ec nC
IECEX	IECEX	IECEX Certificate IEC 60079-0 Explosive atmospheres - General requirements IEC 60079-15 Equipment protection by type of protection "n" Certificate: IECEX EPS 14.0001X Temperature Code: T4 Type of Protection: ec nC
Class I Div 2		CSA Certificate Power Supplies for Hazardous Location Applicable for Canada and US CSA Class: 5318-01 (Canada), 5318-81 (USA) Temperature Code: T4 Groups: A, B, C and D
Marine (DNV)		DNV Certificate DNV Type approved product Certificate: TAA00001ST Temperature: Class D Humidity: Class B Vibration: Class C EMC: Class A Enclosure: Class A
Marine (ABS)	ABS	ABS Design Assessment Certificate ABS (American Bureau of Shipment) assessed product Certificate: 17-HG1599236-PD

IEC 60068-2-60	<p>Corrosion IEC 60068-2-60 Method 4 ✓</p>	<p>Manufacturer's Declaration (Online Document) Environmental Tests, Flowing Mixed Gas Corrosion Test Test Ke - Method 4 H2S: 10ppb NO2: 200ppb Cl2: 10ppb SO2: 200ppb Test Duration: 3 weeks, which simulates a service life of 10 years.</p>
ISA-71.04 G3	<p>Corrosion G3-ISA-71.04 ✓</p>	<p>Manufacturer's Declaration (Online Document) Airborne Contaminants Corrosion Test Severity Level: G3 Harsh H2S: 100ppb NOx: 1250ppb Cl2: 20ppb SO2: 300ppb Test Duration: 3 weeks, which simulates a service life of 10 years</p>
VDMA 24364	<p>LABS VDMA 24364-C1-LW</p>	<p>Paint Wetting Impairment Substances Test (or LABS-Test) Tested for Zone 2 and test class C1 according to VDMA 24364-C1-LW for solvents and water-based paints</p>

21. REGULATORY PRODUCT COMPLIANCE

EU Declaration of Conformity		<p>The CE mark indicates conformance with the - EMC directive - ATEX directive - RoHS directive</p>
REACH Directive	<p>REACH ✓</p>	<p>Manufacturer's Statement EU-Directive regarding the Registration, Evaluation, Authorization and Restriction of Chemicals</p>
WEEE Directive		<p>Manufacturer's Statement EU-Regulation on Waste Electrical and Electronic Equipment Registered in Germany as business to business (B2B) products.</p>
EAC TR Registration		<p>EAC Certificate EAC EurAsian Conformity - Registration Russia, Kazakhstan and Belarus 8504408200, 8504409000</p>

22. PHYSICAL DIMENSIONS AND WEIGHT

Weight	450g / 0.99lb
DIN rail	Use 35mm DIN rails according to EN 60715 or EN 50022 with a height of 7.5 or 15mm. The DIN rail depth must be added to the unit depth (102mm) to calculate the total required installation depth.
Installation Clearances	See chapter 2

Fig. 22-1 **Front view**

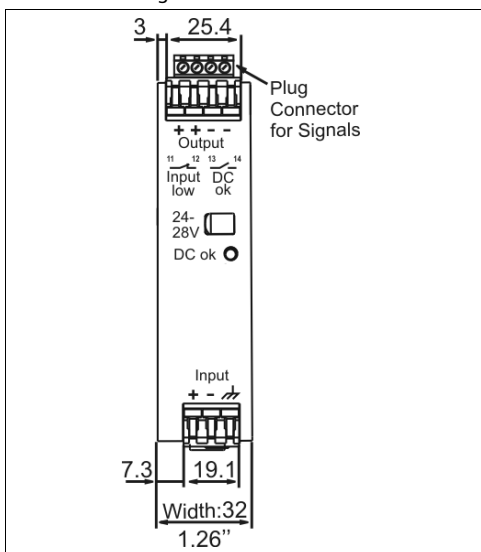
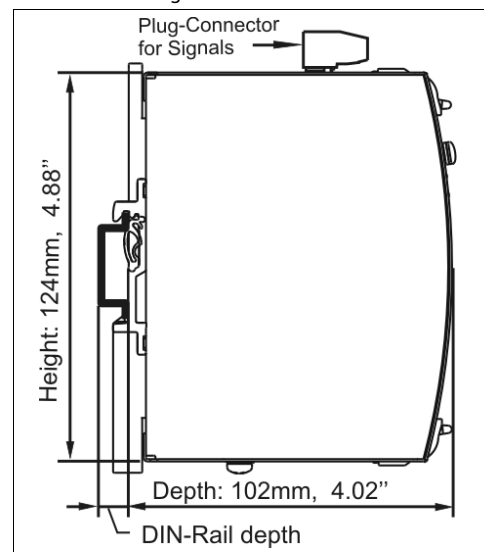

Fig. 22-2 **Side view**



23. ACCESSORIES

23.1. ZM1.WALL - WALL MOUNTING BRACKET

This bracket is used to mount specific Dimension units onto a flat surface without utilizing a DIN rail. The two aluminum brackets and the black plastic slider of the unit have to be removed, so that the two steel brackets can be mounted.

Fig. 23-1 ZM1.Wall Wall mounting bracket*)

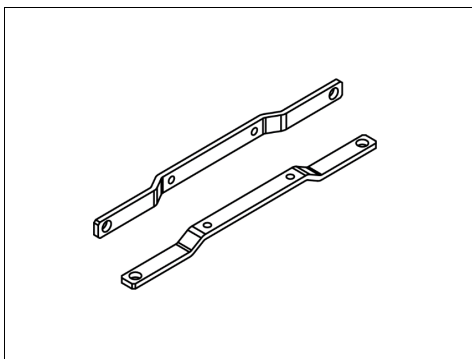

*) PSU for illustration purpose only.

Fig. 23-2 Wall mounting with DIN rail brackets*)

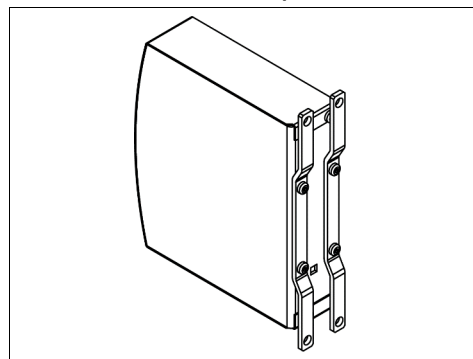

23.2. ZM10.WALL - WALL/PANEL MOUNT BRACKET

This bracket is used to mount the devices on a wall/panel without utilizing the DIN rail. The bracket can be mounted without detaching the DIN rail brackets from the power supply.

Fig. 23-2 ZM10.Wall Wall mounting bracket*)

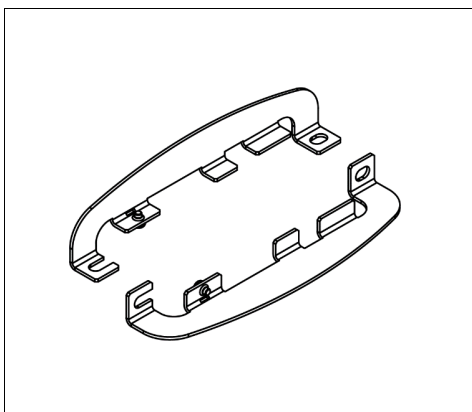

*) PSU for illustration purpose only.

Fig. 23-4 Side mounting with DIN rail brackets*)

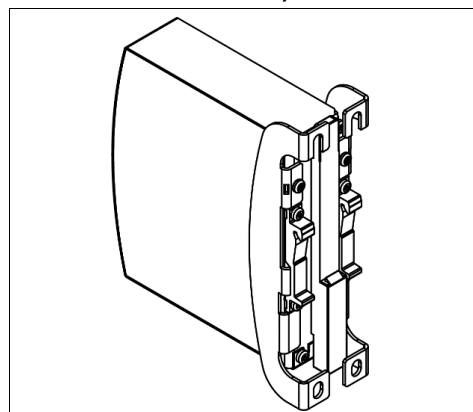

23.3. ZM11.SIDE - SIDE MOUNTING BRACKET

This bracket is used to mount Dimension units sideways with or without utilizing a DIN rail. The two aluminum brackets and the black plastic slider of the unit have to be detached, so that the steel brackets can be mounted.

For sideways DIN rail mounting, the removed aluminum brackets and the black plastic slider need to be mounted on the steel bracket.

Fig. 23-5 **ZM11.SIDE Side mounting bracket*)**

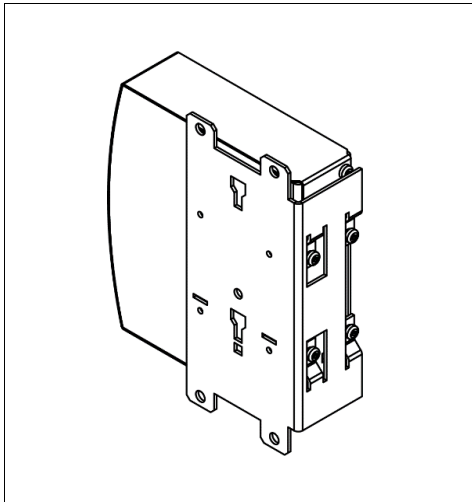

*) PSU for illustration purpose only.

Fig. 23-6 **Side mounting with DIN rail brackets*)**

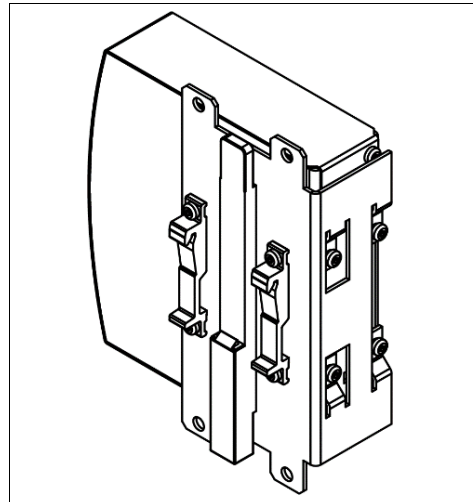

23.4. YR2.DIODE REDUNDANCY MODULE



The YR2.DIODE is a dual redundancy module, which has two diodes as decoupling devices included. It can be used for various purposes.

The most popular application is to configure highly reliable and true redundant power supply systems. Another interesting application is the separation of sensitive loads from non-sensitive loads.

This avoids the distortion of the power quality for the sensitive loads which can cause controller failures.

Due to the compact design, the unit is very slender and only requires 32mm width on the DIN rail.

24. APPLICATION NOTES

24.1. PEAK CURRENT CAPABILITY

Solenoids, contactors and pneumatic modules often have a steady state coil and a pick-up coil. The inrush current demand of the pick-up coil is several times higher than the steady-state current and usually exceeds the nominal output current (including the PowerBoost) The same situation applies, when starting a capacitive load.

Branch circuits are often protected with circuit breakers or fuses. In case of a short or an overload in the branch circuit, the fuse needs a certain amount of over-current to trip or to blow. The peak current capability ensures the safe operation of subsequent circuit breakers.

Assuming the input voltage is turned on before such an event, the built-in large sized output capacitors inside the DC/DC converter can deliver extra current. Discharging this capacitor causes a voltage dip on the output. The following two examples show typical voltage dips:

Fig. 24-1 **Peak loading with 2x nominal current for 50ms, typ.**

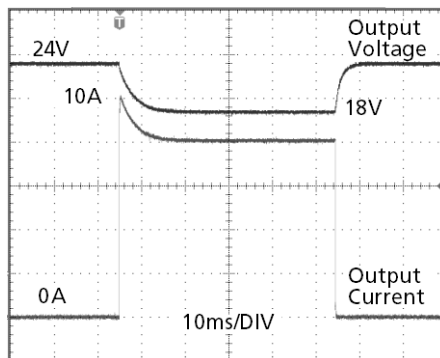

Peak load 10A (resistive load) for 50ms
Output voltage dips from 24V to 18V.

Fig. 24-2 **Peak loading with 4x nominal current for 5ms, typ.**

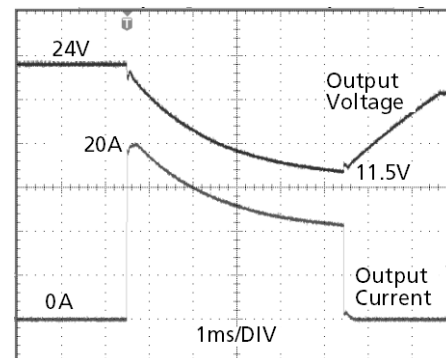

Peak load 20A (resistive load) for 5ms
Output voltage dips from 24V to 11.5V.

24.2. BACK-FEEDING LOADS

Loads such as decelerating motors and inductors can feed voltage back to the DC/DC converter. This feature is also called return voltage immunity or resistance against Back- E.M.F. (Electro Magnetic Force).

This DC/DC converter is resistant and does not show malfunctioning when a load feeds back voltage to the DC/DC converter. It does not matter, whether the DC/DC converter is on or off.

The maximum allowed feed-back-voltage is 30Vdc. The absorbing energy can be calculated according to the built-in large sized output capacitance which is specified in chapter 5.

24.3. INDUCTIVE AND CAPACITIVE LOADS

The unit is designed to supply any kind of loads, including unlimited capacitive and inductive loads.

24.4. CHARGING OF BATTERIES

The DC/DC converter can be used to charge lead-acid or maintenance free batteries. (Two 12V batteries in series)

Instructions for charging batteries:

- a) Ensure that the ambient temperature of the DC/DC converter is below 45°C
- b) Do not use DC/DC converters in mounting orientations other than the standard mounting orientation (input terminals on the bottom and output terminals on top of the unit).
- c) Set output voltage (measured at no load and at the battery end of the cable) very precisely to the end-of-charge voltage.

End-of-charge voltage	27.8V	27.5V	27.15V	26.8V
Battery temperature	10°C	20°C	30°C	40°C

- d) Use a 6A or 10A circuit breaker (or blocking diode) between the DC/DC converter and the battery.
- e) Ensure that the output current of the DC/DC converter is below the allowed charging current of the battery.
- f) Use only matched batteries when putting 12V types in series.
- g) The return current to the DC/DC converter (battery discharge current) is typ. 26.4mA when the DC/DC converter is switched off (except in case a blocking diode is utilized).

24.5. EXTERNAL INPUT PROTECTION

The unit is tested and approved for branch circuits up to 50A. An external protection is only required, if the supplying branch has an ampacity greater than this. Check also local codes and local requirements. In some countries local regulations might apply.

If an external fuse is necessary or utilized, minimum requirements need to be considered to avoid nuisance tripping of the circuit breaker. A minimum value of 10A B- or 8A C-Characteristic breaker should be used.

24.6. REQUIREMENTS FOR THE SUPPLYING SOURCE

In certain circumstances, the input filter of the DC/DC converter can show a resonant effect which is caused by the supplying network. Especially when additional external input filters are utilized, a superimposed AC voltage can be generated on the input terminals of the DC/DC converter which might cause a malfunction of the unit. Therefore, additional input filters are not recommended. To avoid the resonant effects, the minimal resistance of the supplying network which depends on the inductance of the input network, shall be above the boundary curve in Fig. 24-3.

Fig. 24-3 External input filter requirements to avoid filter instabilities

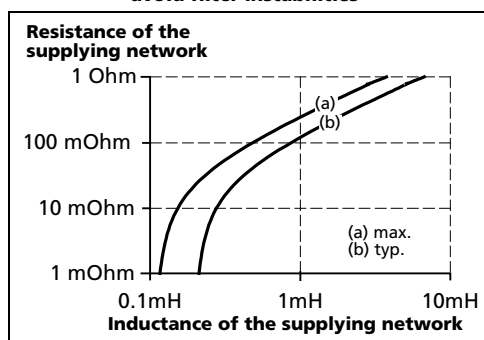

24.7. PARALLEL USE TO INCREASE OUTPUT POWER

The DC/DC-converter can be paralleled to increase the output power. There are no feature included which balances the load current between the DC/DC converters. Therefore some restrictions and limitations apply. The DC/DC converter with the higher adjusted output voltage draws current until it goes into current limitation. This means no harm or switch-off to this DC/DC converter as long as the ambient temperature stays below 45°C. The CD5.241-S1 can also be paralleled with power supplies from the DIMENSION CT, QS or QT-series. For other power supplies consult PULS. Set the "single use / parallel use" jumper to "parallel use" if such an option is available.

The output voltages of all DC/DC converters shall be adjusted to the same value ($\pm 100\text{mV}$) at full load. A fuse or diode on the output of each unit is only required if more than three units are connected in parallel. This avoid that more than 2 times of the nominal output current can flow backwards into the DC/DC converter in case the output stage of the DC/DC converter has a defect. If a fuse (or circuit breaker) is used, choose one with approximately 150% of the rated output current of one DC/DC converter. Keep an installation clearance of 15mm (left / right) between two DC/DC converters and avoid installing the DC/DC converters on top of each other. Do not use DC/DC converters in parallel in mounting orientations other than the standard mounting orientation (input terminals on the bottom and output terminals on top of the unit).

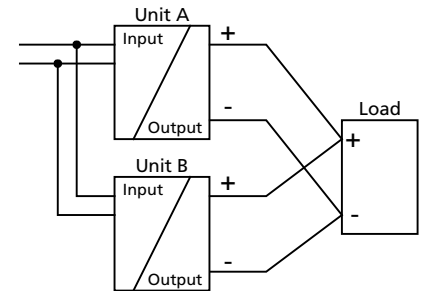

24.8. PARALLEL USE FOR REDUNDANCY

The DC/DC converters can be paralleled for redundancy to gain higher system availability. Redundant systems require a certain amount of extra power to support the load in case one DC/DC converter fails. The simplest way is to put two DC/DC converters in parallel. This is called a 1+1 redundancy. In case one DC/DC converter fails, the other one is automatically able to support the load current without any interruption. Redundant systems for a higher power demand are usually built in an N+1 method. E.g. five DC/DC converters, each rated for 5A are paralleled to build a 20A redundant system.

Furthermore, 1+1 redundant systems can be built by using a DC/DC converter powered from a battery and a power supply with AC input.

Please note: This simple way to build a redundant system does not cover failures such as an internal short circuit in the secondary side of the DC/DC converter. In such a case, the defect unit becomes a load for the other DC/DC converters and the output voltage can not be maintained any more. This can only be avoided by utilizing decoupling diodes which are included in the decoupling module YR2.DIODE.

Recommendations for building redundant power systems:

- a) Use separate input fuses for each DC/DC converter.
- b) Monitor the individual DC/DC converter units. A DC-OK LED and a DC-OK contact is included in the DC/DC-converter. This feature reports a faulty unit.
- c) 1+1 Redundancy is allowed up to an ambient temperature of 60°C
N+1 Redundancy is allowed up to an ambient temperature of 45°C
- d) It is desirable to set the output voltages of all units to the same value ($\pm 100\text{mV}$) or leave it at the factory setting.

24.9. DAISY CHAINING OF OUTPUTS

Daisy chaining (jumping from one DC/DC converter output to the next) is allowed as long as the average output current through one terminal pin does not exceed 25A. If the current is higher, use a separate distribution terminal block.

Fig. 24-4 Daisy chaining of outputs

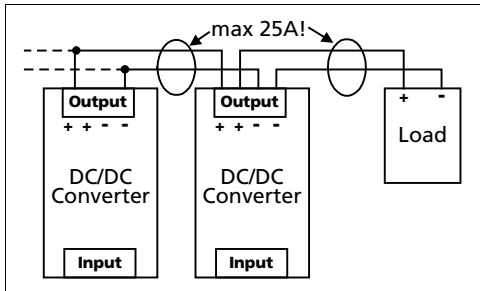
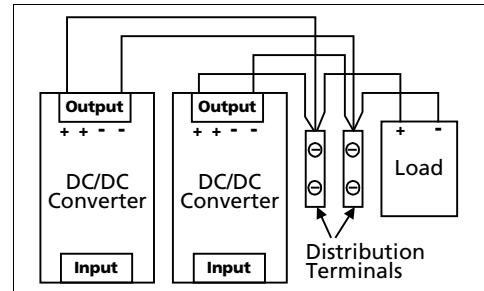
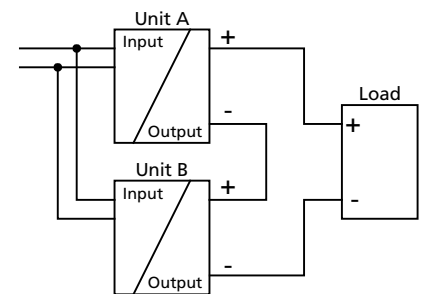

Fig. 24-5 Using distribution terminals



24.10. SERIES OPERATION

DC/DC converters of the exact same type can be connected in series for higher output voltages. It is possible to connect as many units in series as needed, providing the sum of the output voltage does not exceed 150Vdc. Voltages with a potential above 60Vdc are not SELV any more and can be dangerous. Such voltages must be installed with a protection against touching. Earthing of the output is required when the sum of the output voltage is above 60Vdc. Avoid return voltage (e.g. from a decelerating motor or battery) which is applied to the output terminals. Keep an installation clearance of 15mm (left / right) between two DC/DC converters and avoid installing the DC/DC converters on top of each other. Do not use DC/DC converters in series in mounting orientations other than the standard mounting orientation (input terminals on the bottom and output terminals on top of the unit).



24.11. USE IN A TIGHTLY SEALED ENCLOSURE

When the DC/DC converter is installed in a tightly sealed enclosure, the temperature inside the enclosure will be higher than outside. In such situations, the inside temperature defines the ambient temperature for the DC/DC converter.

The following measurement results can be used as a reference to estimate the temperature rise inside the enclosure.

The DC/DC converter is placed in the middle of the box, no other heat producing items are inside the box

Enclosure:	Rittal Typ IP66 Box PK 9516 100, plastic, 110x180x165mm
Load:	24V, 4A; (=80%) load is placed outside the box
Input:	24Vdc
Temperature inside enclosure:	42.8°C (in the middle of the right side of the DC/DC converter with a distance of 2cm)
Temperature outside enclosure:	24.0°C
Temperature rise:	18.8K

24.12. MOUNTING ORIENTATIONS

Mounting orientations other than input terminals on the bottom and output on the top require a reduction in continuous output power or a limitation in the max. allowed ambient temperature. The amount of reduction influences the lifetime expectancy of the DC/DC converter. Therefore, two different derating curves for continuous operation can be found below:

Curve A1 Recommended output current.

Curve A2 Max allowed output current (results in approximately half the lifetime expectancy of A1).

Fig. 24-6
Mounting Orientation A
(Standard orientation)

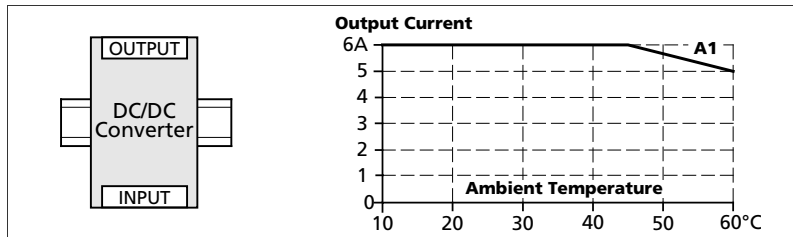

Fig. 24-7
Mounting Orientation B
(Upside down)

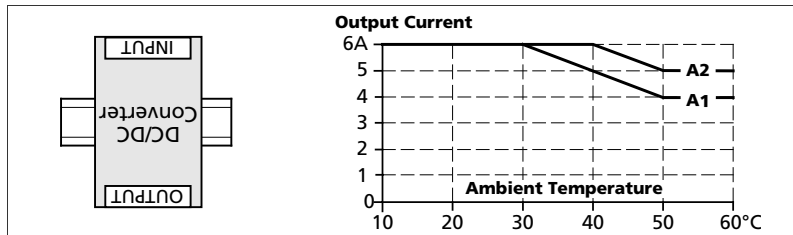

Fig. 24-8
Mounting Orientation C
(Table-top mounting)

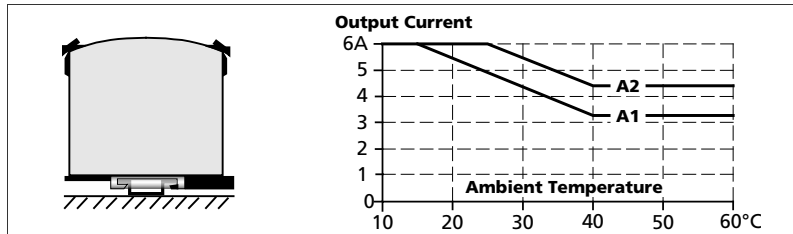

Fig. 24-9
Mounting Orientation D
(Horizontal cw)

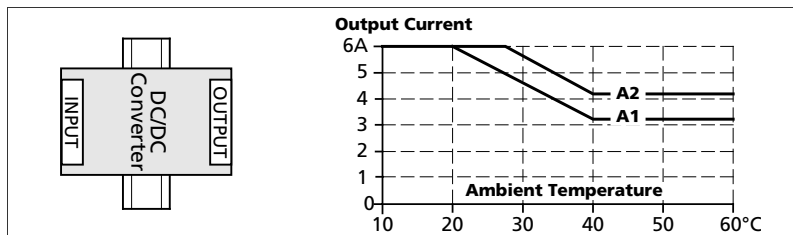

Fig. 24-10
Mounting Orientation E
(Horizontal ccw)

