

Visual Signals

LIGHT EMITTING DIODE BEACONS

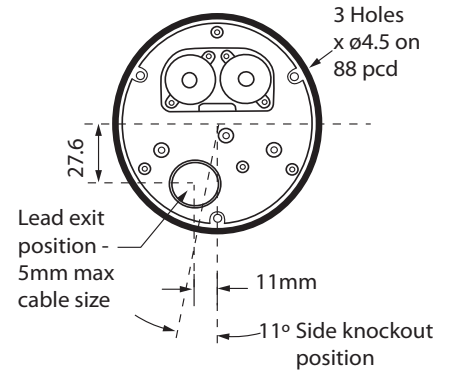
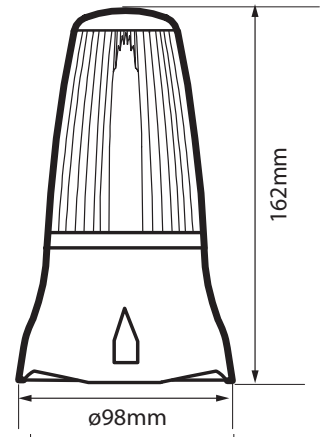

LED Tri-Colour Visual & Audible Beacon > LEDA125-01 PLC Controllable Series

Product overview

The LEDA125-01 offers maximum flexibility in terms of visual and audible requirements.

The beacon can produce 3 colours, Amber, Green and Red in conjunction with an audible signal. Two piezo sounders situated in the base of the unit can be

synchronised with any colour and flash rate required. The unit requires high or low voltage inputs to function (plc / relays etc).

Ideally suited to status control the beacon is a cost effective alternative to the traditional tower light. An M12 sealing grommet in the base allows for cable entry and termination inside the enclosure. Maximum cable size is 5mm.

Features

- Continuously rated
- LED long life and extra bright
- Suitable for surface or wall mounting
- Optional wall bracket & guard available - see accessories
- 3 point fix
- 360° light output around the vertical axis
- Dustproof and Weatherproof

Material

UV Stable Polycarbonate Lens
UV Stable ABS Plastic Base

LEDA125-01 Series > Ordering Information

Code No:	Voltage:	Light Source:	Current:
LEDA125-01	24v Dc ---	48 SM LEDs	Amber 350mA Green/Red 250mA

Kg 0.33

°C -20+45

IP 65

dB 90

INDUSTRIAL

APPROVALS and CONFORMITIES

