

SIRIUS

Überwachungsrelais zur mehrphasigen Stromüberwachung S00 / S0

Monitoring relays for multi-phase current monitoring S00 / S0

Relais de surveillance pour surveillance de courants polyphasés S00 / S0

Relé de vigilancia para vigilar corrientes polifásicas S00 / S0

Relè di sorveglianza per la sorveglianza di correnti polifase S00 / S0

Relés de monitoramento para o monitoramento de corrente multifase S00 / S0

Çok fazlı akım kontrolü için kontrol rölesi S00 / S0

Контрольные реле для контроля силы тока в многофазных сетях S00 / S0

用于监视多相电流的监控继电器 S00 / S0



IEC / EN 60947-4-1

IEC / EN 60947-5-1

Betriebsanleitung	Operating Instructions	Instructions de service	Instructivo	Istruzioni operative
Instruções de Serviço	İşletme kılavuzu	Руководство по эксплуатации	使用说明	

	Deutsch	English	Français
	Vor der Installation, dem Betrieb oder der Wartung des Geräts muss diese Anleitung gelesen und verstanden werden.	Read and understand these instructions before installing, operating, or maintaining the equipment.	Ne pas installer, utiliser ou intervenir sur cet équipement avant d'avoir lu et assimilé les présentes instructions et notamment les conseils de sécurité et mises en garde qui y figurent.
	⚠ GEFAHR	⚠ DANGER	⚠ DANGER
	Gefährliche Spannung. Lebensgefahr oder schwere Verletzungsgefahr. Vor Beginn der Arbeiten Anlage und Gerät spannungsfrei schalten.	Hazardous voltage. Will cause death or serious injury. Turn off and lock out all power supplying this device before working on this device.	Tension électrique. Danger de mort ou risque de blessures graves. Mettre hors tension avant d'intervenir sur l'appareil.
	VORSICHT	CAUTION	PRUDENCE
	Eine sichere Gerätefunktion ist nur mit zertifizierten Komponenten gewährleistet.	Reliable functioning of the equipment is only ensured with certified components.	La sécurité de fonctionnement de l'appareil n'est garantie qu'avec des composants certifiés.
	Español	Italiano	Português
	Leer y comprender este instructivo antes de la instalación, operación o mantenimiento del equipo.	Leggere con attenzione queste istruzioni prima di installare, utilizzare o eseguire manutenzione su questa apparecchiatura.	Ler e compreender estas instruções antes da instalação, operação ou manutenção do equipamento.
	⚠ PELIGRO	⚠ PERICOLO	⚠ PERIGO
	Tensión peligrosa. Puede causar la muerte o lesiones graves. Desconectar la alimentación eléctrica antes de trabajar en el equipo.	Tensione pericolosa. Può provocare morte o lesioni gravi. Scollegare l'alimentazione prima di eseguire interventi sull'apparecchiatura.	Tensão perigosa. Perigo de morte ou ferimentos graves. Desligue a alimentação elétrica e proteja contra o religamento, antes de iniciar o trabalho no equipamento.
	PRECAUCIÓN	CAUTELA	CUIDADO
	El funcionamiento seguro del aparato sólo está garantizado con componentes certificados.	Il funzionamento sicuro dell'apparecchiatura è garantito soltanto con componenti certificati.	O funcionamento seguro do aparelho apenas pode ser garantido se forem utilizados os componentes certificados.
	Türkçe	Русский	中文
	Cihazın kurulumundan, çalıştırılmasından veya bakıma tabi tutulmasından önce, bu kılavuzun okunmuş ve anlaşılmiş olması gerekmektedir.	Перед установкой, вводом в эксплуатацию или обслуживанием устройства необходимо прочесть и понять данное руководство.	安装、使用和维修本设备前必须先阅读并理解本说明。
	⚠ TEHLİKE	⚠ ОПАСНО	⚠ 危险
	Tehlikeli gerilim. Ölüm tehlikesi veya ağır yaralanma tehlikesi. Çalışmalara başlamadan önce, sistemin ve cihazın gerilim beslemesini kapatınız.	Опасное напряжение. Опасность для жизни или возможность тяжелых травм. Перед началом работ отключить подачу питания к установке и к устройству.	危险电压。可能导致生命危险或重伤危险。 操作设备时必须确保切断电源。
	ÖNEMLİ DİKKAT	ОСТОРОЖНО	小心
	Cihazın güvenli çalışması ancak sertifikalı bileşenler kullanılması halinde garanti edilebilir.	Безопасность работы устройства гарантируется только при использовании сертифицированных компонентов.	只有使用经过认证的部件才能保证设备的正常运转。

Technical Assistance: Telephone: +49 (0) 911-895-5900 (8° - 17° CET) E-mail: technical-assistance@siemens.com Internet: www.siemens.com/industrial-controls/technical-assistance	Fax: +49 (0) 911-895-5907	SIEMENS AG, Technical Assistance Würzburger Str. 121 D-90766 Fürth
---	---------------------------	---

DE	Montage	ES	Montaje	TR	Montaj
EN	Assembly	IT	Montaggio	PY	Монтаж
FR	Montage	PT	Montagem	中文	安装

3RR224.-1F.30

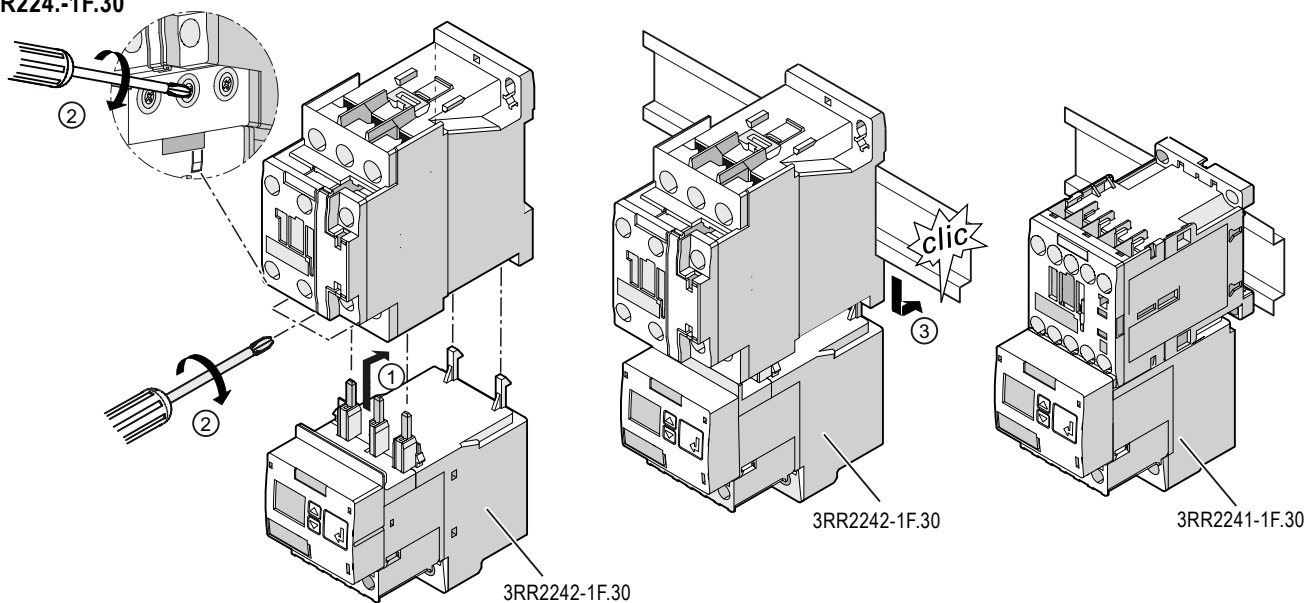

3RR224.-2F.30

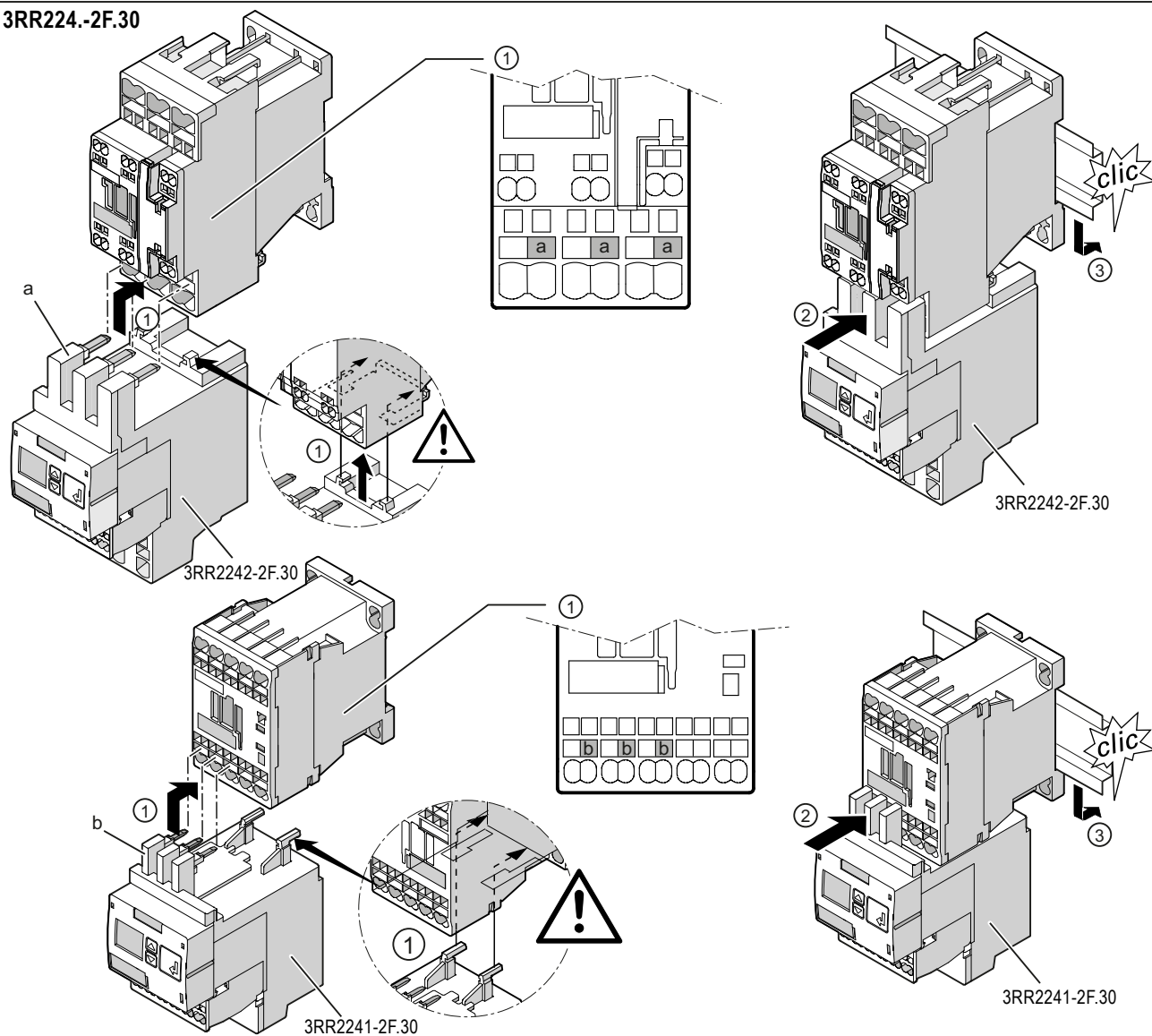

3RR224.-1F.30
3RU29.6-3AA01

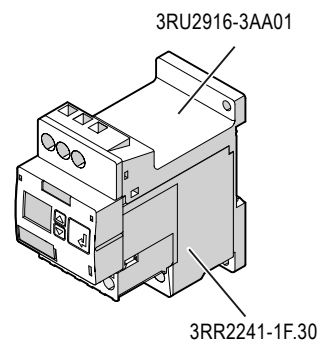
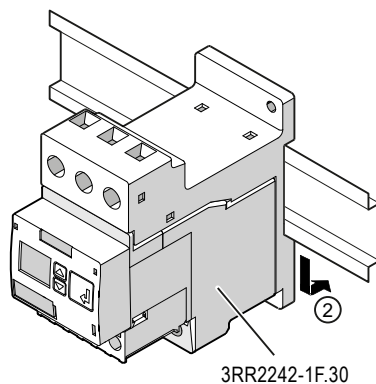
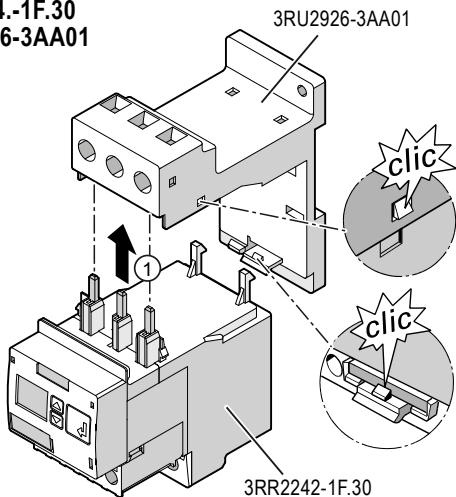

3RR224.-2F.30
3RU29.6-3AC01

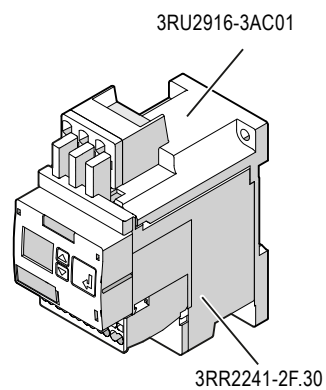
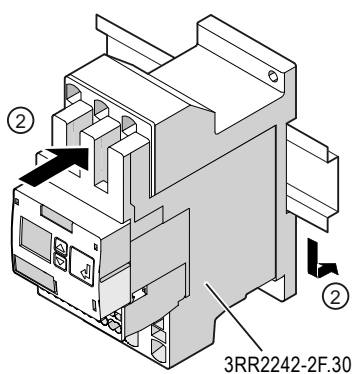
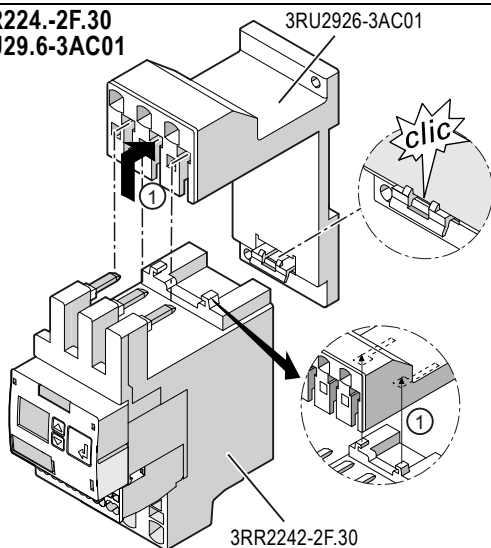

DE	Demontage	ES	Desmontaje	TR	Sökme
EN	Removal	IT	Smontaggio	PY	Демонтаж
FR	Démontage	PT	Desmontagem	中文	拆卸

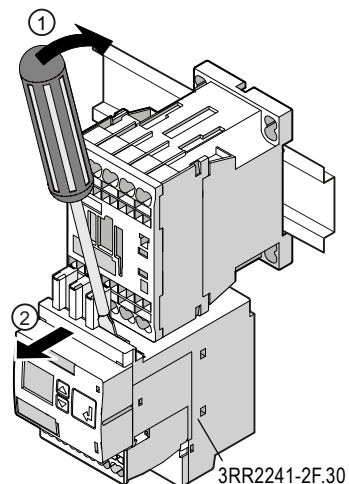
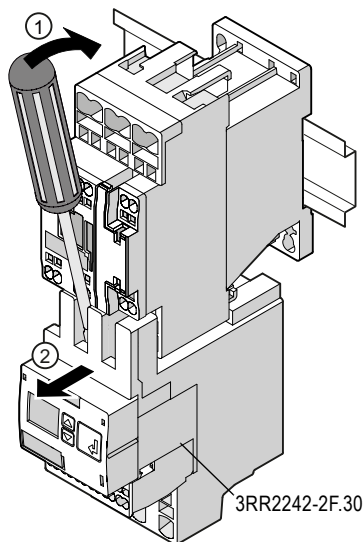
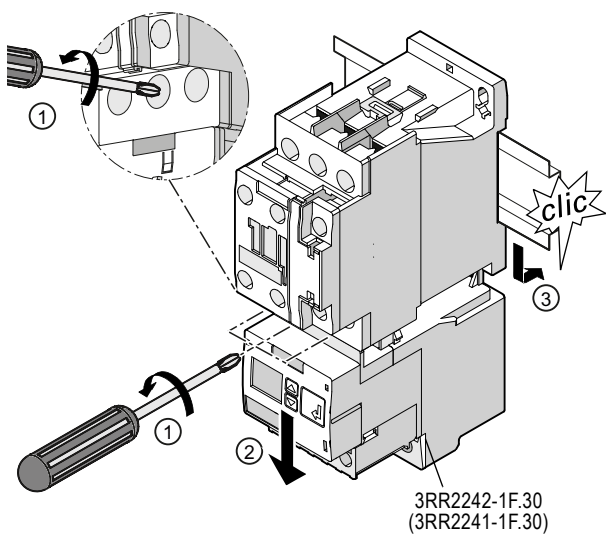

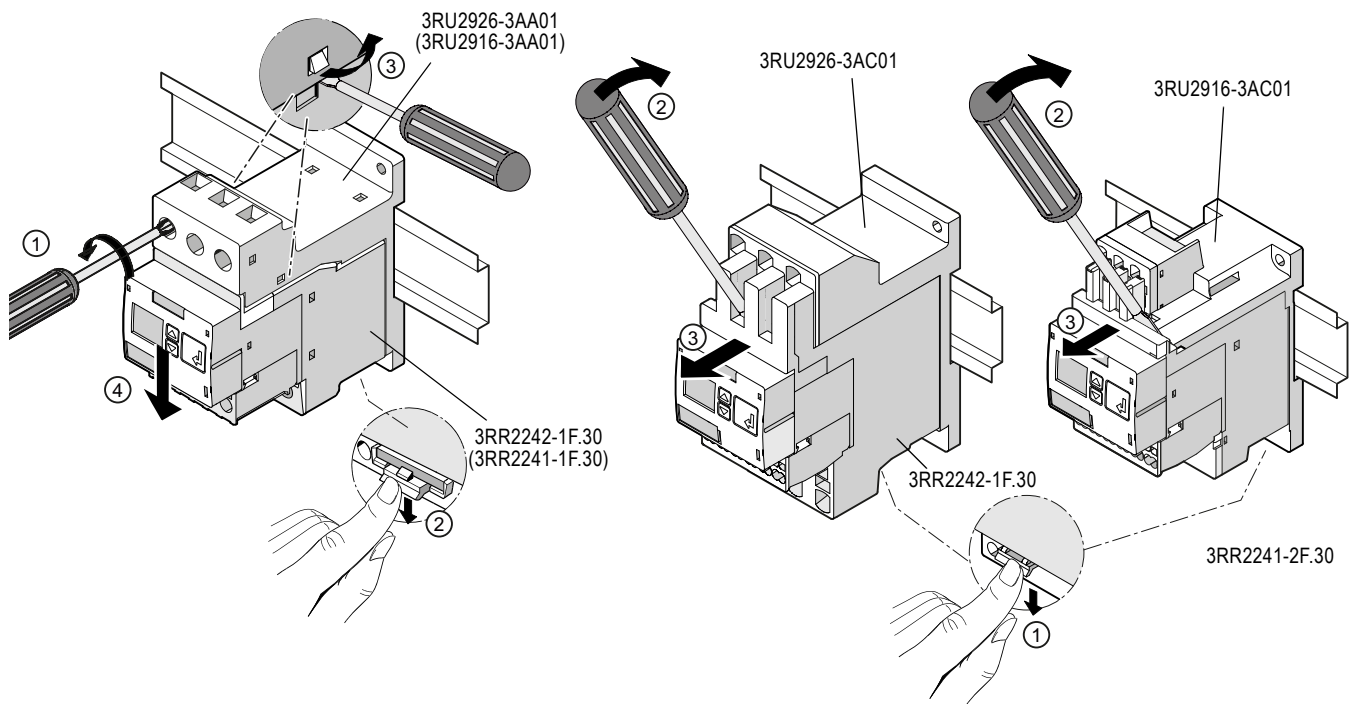

DE	Plombierabdeckung	ES	Cubierta de precinto	TR	Mühürlü kapak
EN	Cover sealing	IT	Cappa di piombatura	PY	Пломбиривочная крышка
FR	Capot de plombage	PT	Cobertura de lacre	中文	铅封盖板

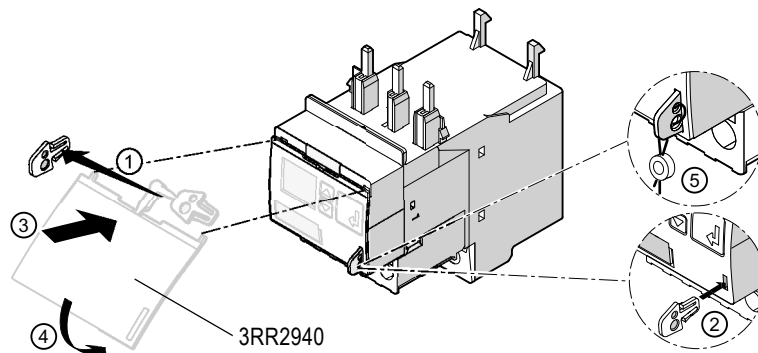

DE	Abnehmbare Klemme tauschen	ES	Sustituir el borne desmontable	TR	Çıkarılabilir klemensleri deęiřtiriniz
EN	Replacing the removable terminal	IT	Sostituzione del morsetto rimovibile	PY	Замениť съемную клемму
FR	Remplacer la borne amovible	PT	Substituir o terminal removível	中文	更換可拆裝式接線盒

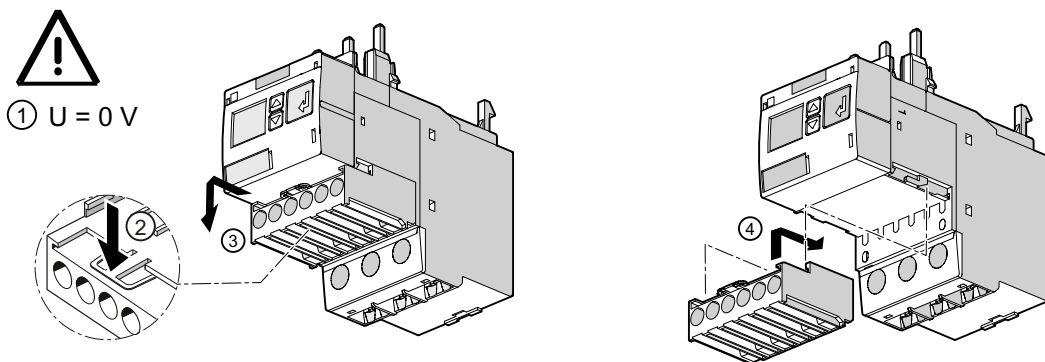

DE	Einstellungen	ES	Ajustes	TR	Ayarlar
EN	Settings	IT	Impostazioni	PY	Настройки
FR	Réglages	PT	Configurações	中文	设置

3RR2241-F.30

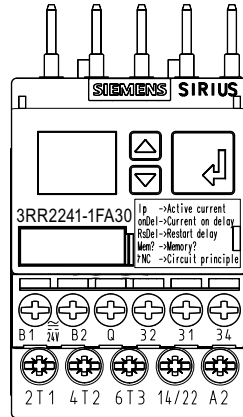



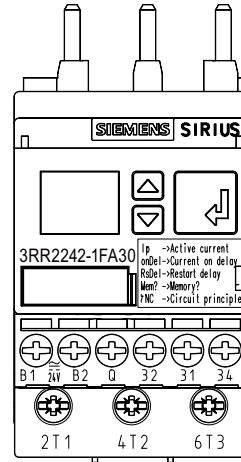

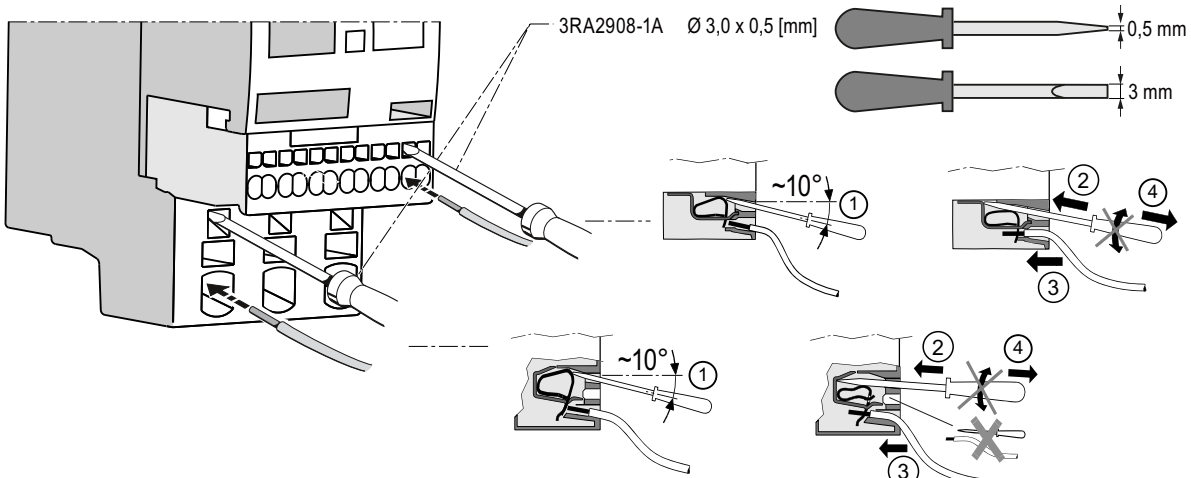

3RR2242-F.30



DE	Anschließen	ES	Conexión	TR	Bağlantı
EN	Connect	IT	Collegamento	PY	Подсоединение
FR	Branchement	PT	Conexão	中文	连接

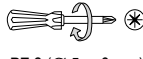

	2T1 / 4T2 / 6T3 / 14/22 / A2		B1 / B2 / Q / 32 / 31 / 34	
	3RR2241-1F.30	3RR2241-2F.30	3RR2241-1F.30	3RR2241-2F.30
	PZ 2 (Ø 5 ... 6 mm) 0,8 ... 1,2 Nm (7 to 10.3 lb in)	3RA2908-1A Ø 3,0 x 0,5 [mm]	PZ 2 (Ø 5 ... 6 mm) 0,8 ... 1,2 Nm (7 to 10.3 lb in)	3RA2908-1A Ø 3,0 x 0,5 [mm]
	2 x (0,5 ... 1,5) mm ² IEC 60947: 2 x (0,75 ... 2,5) mm ² max. 2 x (1 ... 4) mm ²	1 x (0,5 ... 4,0) mm ²	1 x (0,5 ... 4) mm ² 2 x (0,5 ... 2,5) mm ²	2 x (0,25 ... 1,5) mm ²
	—	1 x (0,5 ... 2,5) mm ²	—	2 x (0,25 ... 1,5) mm ²
	2 x (0,5 ... 1,5) mm ² 2 x (0,75 ... 2,5) mm ²	1 x (0,5 ... 2,5) mm ²	1 x (0,5 ... 2,5) mm ² 2 x (0,5 ... 1,5) mm ²	2 x (0,25 ... 1,5) mm ²
AWG	2 x (20 to 12) 1 x 12	1 x (20 to 12)	2 x (20 to 14)	2 x (24 to 16)

	2T1 / 4T2 / 6T3		B1 / B2 / Q / 32 / 31 / 34	
	3RR2242-1F.30	3RR2242-2F.30	3RR2242-1F.30	3RR2242-2F.30
	2.0 ... 2.5 Nm (18 to 22 lb in) PZ 2 (∅ 5 ... 6 mm)			0,8 ... 1,2 Nm (7 to 10.3 lb in) PZ 2 (∅ 5 ... 6 mm)
	2 x (1,0 ... 2,5) mm ² 2 x (2,5 ... 10) mm ²	1 x (1,0 ... 10) mm ²	1 x (0,5 ... 4) mm ² 2 x (0,5 ... 2,5) mm ²	2 x (0,25 ... 1,5) mm ²
	—	1 x (1,0 ... 6,0) mm ²	—	2 x (0,25 ... 1,5) mm ²
	2 x (1 ... 2,5) mm ² IEC 60947: 2 x (2,5 ... 6,0) mm ² max. 1 x 10 mm ²	1 x (1,0 ... 6,0) mm ²	1 x (0,5 ... 2,5) mm ² 2 x (0,5 ... 1,5) mm ²	2 x (0,25 ... 1,5) mm ²
AWG	2 x (16 to 14) 2 x (14 to 8)	1 x (18 to 8)	2 x (20 to 14)	2 x (24 to 16)

DE	Beschreibung
----	--------------

Die Überwachungsrelais werden je nach Ausführung mit einer Hilfsspannung von AC/DC 24 V oder AC/DC 24 V bis 240 V über die Klemmen B1/B2 versorgt.

Die Relais überwachen einen AC-Laststrom (Scheinstrom I_s oder Wirkstrom I_p), der über die Klemmen 1L1 / 2T1, 3L2 / 4T2 und 5L3 / 6T3 des Gerätes fließt, je nach Einstellung auf Über- (I▲ für den Wechslerkontakt 31-32-34, II▲ für den Halbleiterausgang Q) oder Unterschreitung (I▼ für den Wechslerkontakt 31-32-34, II▼ für den Halbleiterausgang Q) oder in Fensterüberwachung (I▲, II▲ und I▼, II▼ ≠ Off).

Der Einstellbereich für die Schwellwerte ist beim 3RR2241 1,6 A bis 16 A und beim 3RR2242 4,0 A bis 40 A.

Wird die Hilfsspannung eingeschaltet, reagiert der Wechslerkontakt und der Halbleiterausgang nach Ablauf der eingestellten Anlaufverzögerungszeit (onDel) nach dem eingestellten Stromprinzip (Ruhestromprinzip NC oder Arbeitsstromprinzip NO).

- Mit Beginn des Stromflusses ($I > 0$) startet die eingestellte Anlaufverzögerungszeit (onDel). Während dieser Zeit führt eine Unter- oder Überschreitung der eingestellten Schwellwerte bzw. ein Blockierstrom-Fehler nicht zu einer Reaktion des Wechslerkontaktes und des Halbleiterausgangs. Über- oder unterschreitet der nun betriebsmäßig fließende Laststrom den zugehörigen eingestellten Schwellwert, beginnt die eingestellte Verzögerungszeit (Del) und die Symbole für den Wechslerkontakt und den Halbleiterausgang blinken. Nach Ablauf dieser Zeit ändern der Wechslerkontakt und der Halbleiterausgang den Schaltzustand. Ist das Gerät auf Auto-Reset eingestellt (Mem = no), reagieren der Wechslerkontakt und der Halbleiterausgang, nachdem die Hystereseschwelle (Hyst) erreicht wird und die Wiedereinschaltverzögerungszeit (RsDel) abgelaufen ist. Die aufgetretene Über- oder Unterschreitung wird also nicht gespeichert. Wird Hand-Reset gewählt (Mem = yes), bleibt der Wechslerkontakt im aktuellen Schaltzustand, auch wenn der Laststrom wieder einen zulässigen Wert annimmt. Dieser gespeicherte Fehlerzustand kann durch gleichzeitiges Drücken der Tasten ‚Up‘ ▲ und ‚Down‘ ▼ oder durch Aus- und Einschalten der Hilfsspannung zurückgesetzt werden. Der Halbleiterausgang reagiert immer im Auto-Reset.
- Wird ein Kabelbruch erkannt (Nullstrom in den Stromzweigen 1L1 / 2T1, 3L2 / 4T2 oder 5L3 / 6T3), werden alle laufenden Verzögerungszeiten (onDel, RsDel, Del) abgebrochen und der Wechslerkontakt sowie der Halbleiterausgang ändern ihren Schaltzustand. Mit Beginn des Stromflusses ($I > 0$) in allen Stromzweigen (1L1 / 2T1, 3L2 / 4T2 und 5L3 / 6T3) reagieren der Wechslerkontakt und der Halbleiterausgang wieder entsprechend den vorgenommenen Einstellungen.
- Weisen die Lastströme an den Klemmen 1L1 / 2T1, 3L2 / 4T2 und 5L3 / 6T3 die falsche Phasenfolge auf ( = yes), ändern der Wechslerkontakt und der Halbleiterausgang unverzüglich ihren Schaltzustand.
- Ist die Fehlerstrom-Überwachung aktiviert ($I >> \text{---} = \text{yes}$) und steigt der Summenstrom der Lastströme an den Klemmen 1L1 / 2T1, 3L2 / 4T2 und 5L3 / 6T3 über den zulässigen Grenzwert an, werden alle laufenden Verzögerungszeiten (onDel, RsDel, Del) abgebrochen und der Wechslerkontakt sowie der Halbleiterausgang ändern ihren Schaltzustand (nicht bei Stern-Dreieck-Anlauf).
- Überschreitet der Laststrom während des Hochlaufs oder im laufenden Betrieb den n-fachen Wert ($n \times I \blacktriangle$) des eingestellten Schwellwerts für Überschreitung (I▲), so liegt ein Blockierstrom-Fehler vor. Hierbei wird eine laufende Verzögerungszeit Del abgebrochen und der Wechslerkontakt sowie der Halbleiterausgang ändern ihren Schaltzustand.

Für alle obigen Funktionen gilt, daß bei Auftreten eines Fehlerfalls und Hand-Reset (Mem = yes) der Auslösezustand gespeichert bleibt.

Folgende Fehlertypen werden als Diagnosemeldung mit blinkenden Symbolen auf dem Display angezeigt:

Kabelbruch, falsche Phasenfolge, Fehlerstrom-Überschreitung, Blockierstrom-Fehler, Laststrom-Über-/Unterschreitung des im Menü eingestellten Strom-Schwellwertes.

EN	Description
----	-------------

Depending on the version, the monitoring relays are supplied with an auxiliary voltage of either 24 V AC/DC or 24 - 240 V AC/DC via terminals B1/B2.

The relays monitor an AC load current (apparent current I_s or active current I_p), which flows via terminals 1L1 / 2T1, 3L2 / 4T2 and 5L3 / 6T3 of the device for overshooting (I▲ for the changeover contact 31-32-34, II▲ for the semiconductor output Q) or undershooting (I▼ for the changeover contact 31-32-34, II▼ for the semiconductor output Q) or in window monitoring (I▲, II▲ and I▼, II▼ ≠ Off), depending on the settings.

The setting range for the threshold values is 1.6 A to 16 A for 3RR2241 and 4.0 A to 40 A for 3RR2242.

If the auxiliary voltage is switched on, the changeover contact and the semiconductor output react after the set startup delay time (onDel) has elapsed according to the specified circuit principle (closed-circuit principle NC or open-circuit principle NO).

- When the current flow begins ($I > 0$), the set startup delay time (onDel) also begins. During this time, overshooting or undershooting the set threshold values or a blocking current fault will not cause a reaction by the changeover contact and the semiconductor output. If the operational load current overshoots or undershoots the respective set threshold value, the set delay time (Del) starts and the symbols for the changeover contact and the semiconductor output flash. After the time has elapsed, the switching statuses of the changeover contact and the semiconductor output change. If the device is set to Automatic Reset (Mem = no), the changeover contact and the semiconductor output react after the hysteresis threshold (Hyst) has been reached and the re-start delay time (RsDel) has elapsed. Any overshooting or undershooting of the limit values will not be stored. If Manual Reset is selected (Mem = yes), the changeover contact will retain its current switching status, even when the load current has returned to a permissible value. This stored fault status can be reset by simultaneously pressing the "Up" ▲ and "Down" ▼ buttons, or by switching the auxiliary voltage off and then back on. The semiconductor output always reacts with Automatic Reset.
- When a cable break has been detected (residual current in current paths 1L1 / 2T1, 3L2 / 4T2 or 5L3 / 6T3) all running delay times (onDel, RsDel, Del) are canceled and the switching statuses of the changeover contact and the semiconductor output change. When the current flow begins ($I > 0$) in all current paths (1L1 / 2T1, 3L2 / 4T2 and 5L3 / 6T3), the changeover contact and the semiconductor output react again according to the settings made.
- When the load currents on terminals 1L1 / 2T1, 3L2 / 4T2 and 5L3 / 6T3 have the wrong phase sequence ( = yes), the switching statuses of the changeover contact and the semiconductor output change without delay.
- When fault current monitoring is activated ($I >> \text{---} = \text{yes}$) and the summation current of the load currents increases on terminals 1L1 / 2T1, 3L2 / 4T2 and 5L3 / 6T3, thereby exceeding the permissible limit value, all running delay times (onDel, RsDel, Del) are canceled and the switching statuses of the changeover contact and the semiconductor output change (not with star-delta (wye-delta) starting).
- If the load current overshoots the n-fold value ($n \times I \blacktriangle$) of the set threshold value for overshooting (I▲) during startup or operation, a blocking current fault exists. In this case, a running delay time Del is canceled and the switching statuses of the changeover contact and the semiconductor output change.

For all of the above functions, the trip condition is stored when a fault occurs and when Manual Reset (Mem = yes) is selected.

The following fault types are shown as diagnostic messages on the display with flashing symbols:

Cable break, incorrect phase sequence, fault current valuation, blocking current faults, load current overshooting and undershooting of the current threshold value set in the menu.

FR	Description
----	-------------

Les relais de surveillance sont alimentés en fonction de la version en tension auxiliaire 24 V AC/DC ou 24 V à 240 V AC/DC via les bornes B1/B2.

Les relais surveillent un courant de charge AC (courant apparent **Is** ou courant actif **Ip**) qui circule via les bornes 1L1 / 2T1, 3L2 / 4T2 et 5L3 / 6T3 de l'appareil en fonction du réglage sur dépassement du seuil supérieur (I▲ pour le contact inverseur 31-32-34, II▲ pour la sortie statique Q) ou dépassement du seuil inférieur (I▼ pour le contact inverseur 31-32-34, II▼ pour la sortie statique Q) ou surveillance de fenêtre (I▲, II▲ et I▼, II▼ ≠ Off).

La plage de réglage des seuils pour 3RR2241 est comprise entre 1,6 A et 16 A et pour 3RR2242 entre 4,0 A et 40 A.

Si la tension auxiliaire est enclenchée, le contact inverseur et la sortie statique réagissent à expiration de la temporisation de démarrage réglée (**onDel**) selon le principe de courant défini (principe de courant de repos **NF** ou principe de courant de travail **NO**).

- La temporisation de démarrage réglée (**onDel**) commence au début de la conduction du courant ($I > 0$). Un dépassement des seuils inférieur ou supérieur réglés, ou bien un défaut de courant de blocage, n'implique pas de réaction du contact inverseur ni de la sortie statique pendant cette durée. La temporisation réglée (**Del**) est activée si le courant de charge circulant dépasse les seuils supérieur et inférieur réglés respectifs, et les symboles pour le contact inverseur et la sortie statique clignotent. Le contact inverseur et la sortie statique changent d'état de commutation au terme de cette durée. Si l'appareil est réglé sur Auto-Reset (**Mem = no**), le contact inverseur et la sortie statique réagissent après atteinte du seuil d'hystérésis (**Hyst**) et expiration de la temporisation de réenclenchement (**RsDel**). Le dépassement des seuils supérieur ou inférieur n'est pas sauvegardé. La sélection du menu de réglage Reset manuel (**Mem = yes**) permet au contact inverseur et à la sortie statique de rester dans l'état de commutation actuel même si le courant de charge reprend une valeur admissible. Cet état de défaut mémorisé peut être réinitialisé par une activation simultanée des touches "HAUT" ▲ et "BAS" ▼ ou par une mise hors et sous tension de la tension auxiliaire. La sortie statique réagit toujours en Auto-Reset. Si une rupture de câble est détectée (courant résiduel dans les branches de courant 1L1 / 2T1, 3L2 / 4T2 ou 5L3 / 6T3), toutes les temporisations en cours (**onDel**, **RsDel**, **Del**) sont annulées et le contact inverseur ainsi que la sortie statique changent d'état de commutation. Le contact inverseur et la sortie statique réagissent de nouveau conformément aux réglages effectués au début de la conduction du courant ($I > 0$) dans toutes les branches de courant (1L1 / 2T1, 3L2 / 4T2 et 5L3 / 6T3).
- Si les courants de charge présentent un ordre de phases incorrect ( = **yes**) aux bornes 1L1 / 2T1, 3L2 / 4T2 et 5L3 / 6T3, le contact inverseur ainsi que la sortie statique changent immédiatement d'état de commutation.
- Si la surveillance de courant de défaut est activée ($I >> \frac{1}{n} = \text{yes}$) et si le courant sommateur des courants de charge dépasse la valeur seuil admissible aux bornes 1L1 / 2T1, 3L2 / 4T2 et 5L3 / 6T3, toutes les temporisations en cours (**onDel**, **RsDel**, **Del**) sont annulées et le contact inverseur ainsi que la sortie statique changent d'état de commutation (pas avec démarrage étoile-triangle).
- Un défaut de courant de blocage se produit pendant la montée en vitesse ou le fonctionnement si le courant de charge dépasse n-fois la valeur ($n \times I \blacktriangle$) du dépassement du seuil supérieur réglé (I▲). Une temporisation en cours **Del** est annulée et le contact inverseur ainsi que la sortie statique changent d'état de commutation.

Pour toutes les fonctions mentionnées ci-dessus, l'état de déclenchement reste mémorisé en cas de défaut et de reset manuel (**Mem = yes**).

Les types de défaut suivants sont représentés sur l'afficheur sous forme de message de diagnostic par des symboles clignotants :

Rupture de câble, ordre de phases incorrect, dépassement du seuil supérieur du courant de défaut, défaut courant de blocage, dépassement du seuil supérieur / inférieur du courant de charge de la valeur seuil de courant définie dans le menu.

ES	Descripción
----	-------------

Según la versión de que se trate, los relés de vigilancia se alimentan con tensión auxiliar 24 V CA/CC, o bien 24 V hasta 240 V CA/CC por medio de los bornes B1/B2.

Los relés vigilan una corriente de carga CA (corriente aparente **Is** o corriente activa **Ip**) conectada a través de los bornes 1L1 / 2T1, 3L2 / 4T2 y 5L3 / 6T3 del dispositivo. Según el ajuste del usuario se vigila un rebasamiento por exceso (I▲ para el contacto inversor 31-32-34, II▲ para la salida de semiconductor Q) o por defecto (I▼ para el contacto inversor 31-32-34, II▼ para la salida de semiconductor Q) o bien se vigila una ventana de valores (I▲, II▲ y I▼, II▼ ≠ Off).

El rango de ajuste para los valores umbrales es de 1,6 A a 16 A para el 3RR2241 y de 4,0 A a 40 A para el 3RR2242.

De conectarse la tensión auxiliar, reaccionan el contacto inversor y la salida de semiconductor una vez transcurrido el tiempo de retardo de arranque ajustado (**onDel**) de acuerdo con el principio de corriente seleccionado (principio de corriente de reposo **NC** o principio de corriente de trabajo **NO**).

- Cuando empieza a circular la corriente ($I > 0$) se inicia el tiempo de retardo de arranque ajustado (**onDel**). Durante este lapso de tiempo, un rebasamiento por exceso o por defecto de los valores umbrales ajustados o un error de corriente de bloqueo no genera una reacción del contacto inversor o de la salida de semiconductor. Si la corriente de carga circulante rebasa por exceso o por defecto el respectivo valor umbral ajustado, se inicia el tiempo de retardo ajustado (**Del**) y los símbolos del contacto inversor y de la salida de semiconductor parpadean. Una vez transcurrido este tiempo, el contacto inversor y la salida de semiconductor modifican el estado de conmutación. Si el dispositivo está ajustado en modo reset automático (**Mem = no**), el contacto inversor y la salida de semiconductor reaccionarán una vez se haya alcanzado el umbral de histéresis (**Hyst**) y haya transcurrido el tiempo de retardo hasta reconexión ajustado (**RsDel**). Es decir, el rebasamiento por exceso o por defecto que se ha detectado no queda memorizado. De utilizarse el modo de reset manual (**Mem = yes**), el contacto inversor permanece en el estado de conmutación actual, incluso si la corriente de carga vuelve a alcanzar un valor permitido. El estado de falla memorizado se puede resetear pulsando a la vez las teclas "Up" ▲ y "Down" ▼ o mediante la desconexión y posterior conexión de la corriente auxiliar. La salida de semiconductor siempre reacciona en modo de reset automático.
- Si se detecta una rotura de hilo (corriente residual en los circuitos 1L1 / 2T1, 3L2 / 4T2 ó 5L3 / 6T3), se interrumpen todos los tiempos de retardo ajustados (**onDel**, **RsDel**, **Del**) y tanto el contacto inversor como la salida de semiconductor modifican su estado de conmutación. Cuando empieza a circular la corriente ($I > 0$) por todos los circuitos (1L1 / 2T1, 3L2 / 4T2 y 5L3 / 6T3), vuelven a reaccionar el contacto inversor y la salida de semiconductor según los ajustes correspondientes.
- Si las corrientes de carga en los bornes 1L1 / 2T1, 3L2 / 4T2 y 5L3 / 6T3 presentan una secuencia de fases incorrecta ( = **yes**), tanto el contacto inversor como la salida de semiconductor modifican su estado de conmutación.
- Si está activada la vigilancia de corriente de defecto ($I >> \frac{1}{n} = \text{yes}$) y aumenta el valor total de la corriente de carga en los bornes 1L1 / 2T1, 3L2 / 4T2 y 5L3 / 6T3 por encima del límite permitido, se interrumpen todos los tiempos de retardo en curso (**onDel**, **RsDel**, **Del**) y tanto el contacto inversor como la salida de semiconductor modifican su estado de conmutación (no con arranque estrella-triángulo).
- Si, durante la aceleración o el funcionamiento a plena marcha, la corriente de carga sobrepasa el valor múltiple n-pleto ($n \times I \blacktriangle$) del valor umbral ajustado como límite superior (I▲), entonces ha surgido una falla por corriente de bloqueo. En este caso se interrumpe el tiempo de retardo **Del** en curso y tanto el contacto inversor como la salida de semiconductor modifican su estado de conmutación.

Para todas las funciones arriba mencionadas se aplica lo siguiente: si surge una falla y se selecciona el modo de reset manual (**Mem = yes**) queda almacenado el estado de disparo.

Los siguientes tipos de error se indican como mensaje de diagnóstico en el display mediante símbolos intermitentes:

Rotura de hilo, secuencia de fases incorrecta, rebasamiento por exceso de la corriente de defecto, falla por corriente de bloqueo, la corriente de carga ha rebasado por exceso o por defecto el umbral de corriente ajustado en el menú.

IT	Descrizione
----	-------------

I relè di sorveglianza sono alimentati, a seconda della versione, con una tensione ausiliaria di 24 V CA/CC o da 24 V a 240 V CA/CC tramite i morsetti B1/B2.

I relè sorvegliano una corrente di carico CA (corrente apparente **Is** o corrente attiva **Ip**) che scorre attraverso i morsetti 1L1 / 2T1, 3L2 / 4T2 e 5L3 / 6T3 dell'apparecchio, a seconda dell'impostazione al superamento per eccesso (I▲ per il contatto di commutazione 31-32-34, II▲ per l'uscita a semiconduttore Q) o per difetto (I▼ per il contatto di commutazione 31-32-34, II▼ per l'uscita a semiconduttore Q) o in sorveglianza finestra (I▲, II▲ e I▼, II▼ ≠ Off).

Il campo di regolazione per i valori di soglia è per 3RR2241 da 1,6 A a 16 A e per 3RR2242 da 4,0 A a 40 A.

Se viene inserita la tensione ausiliaria, il contatto di commutazione e l'uscita a semiconduttore reagiscono una volta scaduto il tempo impostato di ritardo all'avvio (**onDel**) secondo il principio di corrente impostato (principio della corrente di riposo **NC** o principio della corrente di carico **NO**).

- Con l'inizio del flusso di corrente ($I > 0$) si avvia il tempo impostato di ritardo all'avvio (**onDel**). Durante questo tempo, un superamento verso l'alto o verso il basso dei valori di soglia impostati oppure un errore della corrente di bloccaggio non provocano una reazione del contatto di commutazione e dell'uscita a semiconduttore. Se la corrente di carico operativa supera per eccesso o per difetto il relativo valore di soglia impostato, inizia il tempo di ritardo impostato (**Del**) e i simboli per il contatto di commutazione e l'uscita a semiconduttore lampeggiano. Una volta decorso questo tempo, il contatto di commutazione e l'uscita a semiconduttore modificano lo stato di commutazione. Se l'apparecchio è impostato su Auto Reset (**Mem = no**), il contatto di commutazione e l'uscita a semiconduttore reagiscono dopo che la soglia di isteresi (**Hyst**) è stata raggiunta e il tempo di ritardo alla reinserzione (**RsDel**) è scaduto. Il superamento verso l'alto o il basso non viene dunque memorizzato. Se si seleziona Hand Reset (**Mem = yes**), il contatto di commutazione rimane nello stato di commutazione attuale, anche se la corrente di carico assume nuovamente un valore ammissibile. È possibile azzerare questa condizione di errore memorizzata premendo contemporaneamente i tasti "Up" ▲ e "Down" ▼ o disinserendo e reinserendo la tensione ausiliaria. L'uscita a semiconduttori reagisce sempre in Auto Reset.

- Se si rileva una rottura del cavo (corrente zero nei rami 1L1 / 2T1, 3L2 / 4T2 o 5L3 / 6T3), tutti i tempi di ritardo correnti vengono interrotti (**onDel**, **RsDel**, **Del**) mentre il contatto di commutazione e l'uscita a semiconduttore modificano il loro stato di commutazione. Con l'inizio del flusso di corrente ($I > 0$) in tutti i rami (1L1 / 2T1, 3L2 / 4T2 e 5L3 / 6T3), il contatto di inversione e l'uscita a semiconduttore tornano a reagire conformemente alle impostazioni effettuate.
- Se le correnti di carico sui morsetti 1L1 / 2T1, 3L2 / 4T2 e 5L3 / 6T3 presentano una sequenza fasi errata ($\curvearrowright = \text{yes}$), il contatto di commutazione e l'uscita a semiconduttore modificano il loro stato di commutazione.
- Se la sorveglianza della corrente di guasto è attivata ($I >> \frac{1}{3} = \text{yes}$) e la somma delle correnti di carico sui morsetti 1L1 / 2T1, 3L2 / 4T2 e 5L3 / 6T3 aumenta fino a superare il valore limite ammesso, tutti i tempi di ritardo correnti vengono interrotti (**onDel**, **RsDel**, **Del**) mentre il contatto di commutazione e l'uscita a semiconduttore modificano il loro stato di commutazione (non con avviamento stella-triangolo).
- Se la corrente di carico eccede l'ennesimo valore ($n \times I \blacktriangle$) del valore di soglia impostato per il superamento (**I**), durante l'inizializzazione o durante l'esercizio, si presenta un errore di corrente di bloccaggio. In tal caso, il tempo di ritardo corrente **Del** viene interrotto, mentre il contatto di commutazione e l'uscita a semiconduttore modificano il loro stato di commutazione.

Per tutte le suddette funzioni vale la regola che, quando si verifica un errore e si attiva un Hand Reset (**Mem = yes**), lo stato di sgancio resta memorizzato.

I seguenti tipi di errore comportano una segnalazione diagnostica con i simboli lampeggianti sul display: Rottura del cavo, sequenza fasi errata, superamento corrente di guasto, errore corrente di bloccaggio, superamento per eccesso/per difetto del valore di soglia di corrente di carico impostato nel menu.

PT	Descrição
----	-----------

Dependendo do tipo, os relés de monitoramento são alimentados através dos bornes B1/B2 com uma tensão auxiliar de 24 V CA/CC ou de 24 V até 240 V CA/CC.

Os relés supervisionam uma corrente de carga CA (corrente aparente **Is** ou corrente ativa **Ip**), que flui através dos bornes 1L1 / 2T1, 3L2 / 4T2 e 5L3 / 6T3 do equipamento, de acordo com o ajuste para ultrapassagem do limiar superior (**I** para o contato inversor 31-32-34, **I** para a saída do semicondutor Q) ou não alcance do limiar inferior (**I** para o contato inversor 31-32-34, **I** para a saída do semicondutor Q) ou em monitoramento de janelas (**I**, **I** e **I**, **I** \neq **Off**).

A faixa de ajuste para os valores limiares no 3RR2241 é de 1,6 A até 16 A e no 3RR2242 de 4,0 A até 40 A.

Quando é ligada a tensão auxiliar, o contato inversor e a saída do semicondutor reagem após o decurso do tempo de retardo de partida ajustado (**onDel**) segundo o princípio de corrente ajustado (princípio de corrente de repouso **NF** ou princípio de corrente de trabalho **NA**).

- Com o início do fluxo de corrente ($I > 0$) inicia o tempo de retardo de partida ajustado (**onDel**). Durante este tempo, uma ultrapassagem ou não alcance dos valores limiares ajustados ou uma falha de corrente de bloqueio não resulta em uma reação do contato inversor e da saída do semicondutor. Se a corrente de carga, que agora flui operacionalmente, ultrapassar ou não alcançar o valor limiar pertinente ajustado, inicia o tempo de retardo ajustado (**Del**), e os símbolos para o contato inversor e a saída do semicondutor piscam. Após o decurso deste tempo o contato inversor e a saída do semicondutor mudam o estado da conexão. Se o equipamento estiver ajustado em auto-reset (**Mem = no**), o contato inversor e a saída do semicondutor reagem, depois que for alcançado o limiar de histerese (**Hyst**) e tenha decorrido o tempo de retardo de reativação (**RsDel**). A ultrapassagem ou o não alcance, portanto, não é armazenado. Se for selecionado reset manual (**Mem = yes**), o contato inversor permanece no estado de conexão atual, mesmo que a corrente de carga assuma novamente um valor permitido. Este estado de falha armazenado pode ser resetado através do pressionamento simultâneo das teclas "Up" \blacktriangle e "Down" \blacktriangledown ou ligando e desligando-se a tensão auxiliar. A saída do semicondutor sempre reage no reset automático.
- Quando é detectada uma quebra de cabo (corrente zero nas derivações de corrente 1L1 / 2T1, 3L2 / 4T2 ou 5L3 / 6T3), todos os tempos de retardo em andamento (**onDel**, **RsDel**, **Del**) são interrompidos e o contato inversor, bem como a saída do semicondutor, alteram o seu estado de conexão. Com o início do fluxo de corrente ($I > 0$) em todas as derivações de corrente (1L1 / 2T1, 3L2 / 4T2 e 5L3 / 6T3) o contato inversor e a saída do semicondutor reagem novamente de acordo com os ajustes feitos.
- Se as correntes de carga apresentarem a sequência de fase errada nos bornes 1L1 / 2T1, 3L2 / 4T2 e 5L3 / 6T3 ($\curvearrowright = \text{yes}$), o contato inversor, bem como a saída do semicondutor, alteram o seu estado de conexão.
- Se o monitoramento da corrente de falha estiver ativado ($I >> \frac{1}{3} = \text{yes}$) e se a corrente cumulativa das correntes de carga nos bornes 1L1 / 2T1, 3L2 / 4T2 e 5L3 / 6T3 aumentar acima do valor limiar permitido, todos os tempos de retardo em andamento (**onDel**, **RsDel**, **Del**) serão interrompidos e o contato inversor, bem como a saída do semicondutor, alteram o seu estado de conexão (não em partida estrela-triângulo).
- Se durante a partida ou operação a corrente de carga ultrapassar o enésimo valor ($n \times I \blacktriangle$) do valor limiar ajustado para ultrapassagem (**I**), há uma falha de corrente de bloqueio. Aqui é interrompido um tempo de retardo em andamento **Del** e o contato inversor, bem como a saída do semicondutor, alteram o seu estado de conexão.

Para todas as demais funções acima vale, que na ocorrência de uma falha e reset manual (**Mem = yes**), o estado de disparo permanece armazenado.

Os tipos de falha a seguir são exibidos como mensagem de diagnóstico com símbolos intermitentes no display: Quebra de cabo, sequência de fase incorreta, ultrapassagem de corrente de falha, falha de corrente de bloqueio, não alcance/ultrapassagem da corrente de carga em relação ao valor limiar de corrente ajustado no menu.

TR	Tanım
----	-------

Kontrol röleleri, modellerine göre, AC/DC 24V veya AC/DC 24V'den 240V'ye kadar bir yardımcı gerilim ile B1/B2 klemensleri üzerinden beslenirler.

Röleler, cihazın 1L1 / 2T1, 3L2 / 4T2 ve 5L3 / 6T3 klemensleri üzerinden geçen AC yüklü akımını (zahiri akım **Is** veya aktif akım **Ip**) kontrol ederler ve bu, yapılan ayarlamaya göre, aşım (**I** değiştirme kontağı 31-32-34 için, **I** yarı iletken çıkışı Q için) veya altına düşme (**I** değiştirme kontağı 31-32-34 için, **I** yarı iletken çıkışı Q için) veya pencere kontrolü (**I**, **I** ve **I**, **I** \neq **Off**) şeklinde gerçekleşir.

Eşik değerler için ayar aralığı 3RR2241'de 1,6A - 16A ve 3RR2242'de 4,0A - 40A arasında olmaktadır.

Yardımcı gerilim devreye sokulduğunda, değiştirme kontağı ve yarı iletken çıkışı, ayarlanmış olan kalkış gecikme süresinin (**onDel**) dolmasını takiben ayarlanmış olan akım prensibine göre (kapalı akım prensibi **NC** veya açık devre akımı prensibi **NO**) tepki verir.

- Akım gelmesinin başlamasıyla beraber ($I > 0$) ayarlanmış olan kalkış gecikme süresi (**onDel**) start alır. Bu süre zarfında ayarlanan eşik değerlerin aşılması veya bu değerlerin altına düşmesi veya blokaj akım hatası, değiştirme kontağının ve yarı iletken çıkışının tepki vermesine yol açmaz. Artık normal işletim koşulları altında akan yüklü akımın buna uygun ayarlanmış olan eşik değeri aşması ya da bu değerlerin altına düşmesi halinde, ayarlanmış olan gecikme süresi (**Del**) start alır ve değiştirme kontağı ile yarı iletken çıkışının işaretleri yanıp sönmeye başlar. Bu sürenin dolmasından sonra değiştirme kontağı ve yarı iletken çıkışı, devre pozisyonunu değiştirir.
- Cihazın oto resete (**Mem = no**) ayarlanmış olması halinde, değiştirme kontağı ve yarı iletken çıkışı, histerез eşliğine (**Hyst**) ulaşıldığından ve yeniden start için gecikme süresinin (**RsDel**) dolmasından sonra tepki verirler. Yani meydana gelen değer aşım ya da değerin altına düşme durumu hafızalanmaz. Manuel reset (**Mem = yes**) seçilmiş olması halinde, değiştirme kontağı, yüklü akım yeniden izin verilen değeri alsa bile, mevcut devre pozisyonunda kalır. Hafızaya alınan bu hata pozisyonu, "Up" \blacktriangle ve "Down" \blacktriangledown tuşlarına aynı anda basılması ile ya da yardımcı gerilimin kapatılıp yeniden açılması ile sıfırlanabilir. Yarı iletken çıkışı her zaman oto-reset pozisyonunda tepki verir.
- Kablo kırılması teşhis edilmesi halinde (1L1 / 2T1, 3L2 / 4T2 veya 5L3 / 6T3 akım kollarında sıfır akım), halihazırda devrede olan tüm gecikme süreleri (**onDel**, **RsDel**, **Del**) kesintiye uğrarlar ve değiştirme kontağı ile yarı iletken çıkışı, devre pozisyonlarını değiştirirler. Tüm akım kollarına (1L1 / 2T1, 3L2 / 4T2 ve 5L3 / 6T3) akım gelmeye başlamasıyla beraber ($I > 0$) değiştirme kontağı ile yarı iletken çıkışı, yeniden, yapılmış olan ayarlara uygun biçimde tepki verirler.
- 1L1 / 2T1, 3L2 / 4T2 ve 5L3 / 6T3 klemenslerindeki yüklü akımların yanlış faz sırasına sahip olmaları halinde ($\curvearrowright = \text{Evet}$), değiştirme kontağı ile yarı iletken çıkışı, gecikme olmaksızın devre pozisyonlarını değiştirirler.
- Kaçak akım kontrol tertibatının aktif olması halinde ($I >> \frac{1}{3} = \text{yes}$) ve 1L1 / 2T1, 3L2 / 4T2 ve 5L3 / 6T3 klemenslerindeki yüklü akımların toplam akımının izin verilen limit değerin üzerine çıkması halinde, halihazırda devrede olan tüm gecikme süreleri (**onDel**, **RsDel**, **Del**) kesintiye uğrarlar ve değiştirme kontağı ile yarı iletken çıkışı, devre pozisyonlarını değiştirirler (yıldız-üçgen kalkışta değil).
- Yüklü akımın kalkış sırasında veya işleme esnasında değer aşımı için ayarlanmış olan eşik değeri (**I**) n-kez değerini ($n \times I \blacktriangle$) aşması halinde, blokaj akım hatası var demektir. Bu durumda halihazırda devrede olan gecikme süresi **Del** kesintiye uğrar ve değiştirme kontağı ile yarı iletken çıkışı, devre pozisyonlarını değiştirirler.

Yukarıda sıralanan tüm fonksiyonlar için geçerli olan, hata meydana gelmesi halinde ve manuel resette (**Mem = yes**) trip pozisyonunun hafızalanmış olarak kaldığıdır.

Aşağıdaki hata türleri, teşhis bildirimleri olarak yanıp sönen sembollerle ekranda gösterilirler:

Kablo kırılması, yanlış faz sırası, kaçak akım aşımı, blokaj akım hatası, yüklü akım için menüde ayarlanan akım eşik değerinin aşılması/altına düşmesi.

РУ	Описание
----	----------

В зависимости от исполнения контрольные реле снабжаются вспомогательным напряжением пост./перем. тока 24 В или пост./перем. тока от 24 В до 240 В через клеммы В1/В2.

В зависимости от настройки на превышение установленного значения (I▲ для переключающего контакта 31-32-34, II▲ для полупроводникового выхода Q) или падение ниже заданного значения (I▼ для переключающего контакта 31-32-34, II▼ для полупроводникового выхода Q) реле контролируют переменный ток нагрузки (кажущийся ток Is или активный ток Ip), поступающий через клеммы 1L1 / 2T1, 3L2 / 4T2 и 5L3 / 6T3 прибора, либо работают в режиме контроля окна (I▲, II▲ и I▼, II▼ ≠ Off).

Диапазон установки предельных значений у 3RR2241 колеблется от 1,6 А до 16 А, а у 3RR2242 - от 4,0 А до 40 А.

При включении вспомогательного напряжения переключающий контакт и полупроводниковый выход реагируют по истечении установленного времени задержки пуска (onDel) по установленному принципу тока (принципу тока покоя NC или принципу рабочего тока NO).

• Установленное время задержки пуска (onDel) начинает отсчитываться с началом протекания тока (I > 0). В течение этого времени превышение или падение ниже установленных предельных значений, а также ошибка тока блокировки не вызывают реакции переключающего контакта и полупроводникового выхода.

В случае если протекающий в рабочем режиме ток нагрузки превышает или падает ниже установленного предельного значения, начинается отсчет установленного времени задержки (Del) и символы переключающего контакта и полупроводникового выхода начинают мигать. По прошествии данного времени переключающий контакт и полупроводниковый выход меняют свое коммутационное положение.

В случае если прибор установлен на автоматический сброс (Mem = no), переключающий контакт и полупроводниковый выход реагируют по достижении порога гистерезиса (Hyst) и истечении времени задержки повторного включения (RsDel). Таким образом, возникшее превышение или падение не сохраняются в памяти.

При выборе режима ручного сброса (Mem = yes) переключающий контакт и полупроводниковый выход остаются в текущем коммутационном положении, даже если ток нагрузки вновь достигает допустимого значения. Данное сохраненное аварийное состояние может быть сброшено одновременным нажатием кнопок "Up" ▲ и "Down" ▼ или выключением и включением вспомогательного напряжения. Полупроводниковый выход всегда реагирует в режиме автоматического сброса.

• При обнаружении разрыва кабеля (нулевой ток в ветвях цепи тока 1L1 / 2T1, 3L2 / 4T2 или 5L3 / 6T3), все текущие времена задержки (onDel, RsDel, Del) прерываются, а переключающий контакт и полупроводниковый выход меняют свое коммутационное состояние. С началом протекания тока (I > 0) во всех ответвлениях тока (1L1 / 2T1, 3L2 / 4T2 и 5L3 / 6T3) переключающий контакт и полупроводниковый выход вновь реагируют согласно заданным установкам.

• В случае если токи нагрузки на клеммах 1L1 / 2T1, 3L2 / 4T2 и 5L3 / 6T3 имеют неправильное чередование фаз ( = yes), все текущие времена задержки (onDel, RsDel, Del) прерываются, а переключающий контакт и полупроводниковый выход меняют свое коммутационное состояние.

• При активировании контроля тока утечки (I >> = yes) и повышении суммарного тока нагрузочных токов на клеммах 1L1 / 2T1, 3L2 / 4T2 и 5L3 / 6T3 по сравнению с допустимым предельным значением все текущие времена задержки (onDel, RsDel, Del) прерываются, а переключающий контакт и полупроводниковый выход меняют свое коммутационное состояние (не при пуске звезда-треугольник).

• Если ток нагрузки во время запуска или в ходе работы превышает n-кратное значение (n x I▲) предельного значения, установленного для превышения (I▲), то возникла ошибка тока блокировки. При этом текущее время задержки Del прерывается, а переключающий контакт и полупроводниковый выход меняют свое коммутационное положение.

При всех перечисленных выше функциях при возникновении неисправностей и ручном сбросе (Mem = yes) текущее рабочее состояние сохраняется в памяти.

Следующие типы неисправностей отображаются на дисплее как диагностическое сообщение в виде мигающих символов:

Разрыв кабеля, неправильное чередование фаз, превышение тока утечки, ошибка тока блокировки, превышение или падение ниже заданного в меню предельного значения тока нагрузки.

中文	说明
----	----

监控继电器依照其型号规格不同分别带有一个 24V AC/DC 或 24V 至 240V AC/DC 的辅助电压并经由接线端 B1/B2 被供电。

继电器是按照预先的设置，如超出设定值 (I▲用于转换开关触头 31-32-34, II▲用于半导体输出端 Q) 或低于设定值 (I▼用于转换开关触头 31-32-34, II▼用于半导体输出端 Q) 或视窗监控 (I▲, II▲ 和 I▼, II▼ ≠ Off) 来监测流经设备接线端 1L1/2T1, 3L2/4T2 和 5L3/6T3 处的 AC 负载电流 (视在电流 Is 或有效电流 Ip)。

极限值的设置范围对于 3RR2241 是 1.6A 至 16A, 对于 3RR2242 是 4.0A 至 40A。

当辅助电压被接通后，转换开关触头和半导体输出端在达到了设置的启动延迟时间 (onDel) 之后，按照设置的电流原理 (静态电流原理 NC 或工作电流原理 NO) 进行反应。

• 当电流一开始接通 (I > 0), 已设置的启动延迟时间 (onDel) 即开始计时。在此期间低于或超过设置的极限值或发生堵转电流故障都不会引起转换开关触头和半导体输出端发生反应。

如果工作运行所要求的实际负载电流正在超过或低于相应的设置极限值，则所设置的延迟时间 (Del) 开始计时，并且代表转换开关触头和半导体输出端的指示灯闪烁。在设置时间过后，转换开关触头和半导体输出端将改变通断转换状态。

如果设备被设置为自动复位 (Mem = no), 则当达到滞后极限值 (Hyst) 并且重新接通延迟时间 (RsDel) 过后，转换开关触头和半导体输出端将发生反应。在此所出现的超过或低于极限值的情况不被保存。

如果选择设置了手动复位 (Mem = yes), 则转换开关触头保持当前的通断转换状态，即使负载电流再得到一个允许值。此已被保存的故障状态可以通过同时按住按键 "Up" ▲ 和 "Down" ▼ 或者通过断开和接通辅助电压进行复位。半导体输出端总是在自动复位时进行反应。

• 如果发现电缆断裂 (在电路支路 1L1 / 2T1, 3L2 / 4T2 或 5L3 / 6T3 中是零电流), 则所有当前正在运行的延迟时间 (onDel, RsDel, Del) 被中断, 并且转换开关触头及半导体输出端改变其通断转换状态。随着开始在所有电路支路 (1L1 / 2T1, 3L2 / 4T2 和 5L3 / 6T3) 中通过电流 (I > 0), 转换开关触头和半导体输出端重新按照已有的设置作出反应。

• 如果在接线端 1L1 / 2T1, 3L2 / 4T2 和 5L3 / 6T3 处的负载电流显示出错误的相序 ( = yes), 则转换开关触头和半导体输出端立即改变其通断转换状态。

• 如果故障电流监控功能被激活 (I >> = yes) 并且负载电流在接线端 1L1 / 2T1, 3L2 / 4T2 和 5L3 / 6T3 处的总电流增大到超过所允许的极限值, 则所有当前正在运行的延迟时间 (onDel, RsDel, Del) 被中断, 并且转换开关触头及半导体输出端改变其通断转换状态 (不能在星三角启动时)。

• 如果在启动加速时或在运行过程中负载电流超过设定极限值上限 (I▲) 的 n 倍值 (n x I▲), 则出现一个堵转电流故障。在这种情况下, 则当前正在运行的延迟时间 Del 被中断, 并且转换开关触头及半导体输出端改变其通断转换状态。

对于所有上述功能而言, 当出现一个故障情况和手动复位 (Mem = yes) 时脱扣状态将被保留。

以下的故障类型被作为诊断报告通过显示器上相应指示灯的闪烁显示出来:

电缆断裂, 错误相序, 故障电流超过限定值, 堵转电流故障, 负载电流超过或低于菜单中已设置的电流极限值。

DE	Funktionsdiagramme	ES	Diagramas de funcionamiento	TR	Fonksiyon diyagramları
EN	Functional diagrams	IT	Diagrammi funzionali	РУ	Функциональные диаграммы
FR	Diagrammes fonctionnels	PT	Diagramas funcionais	中文	功能图表

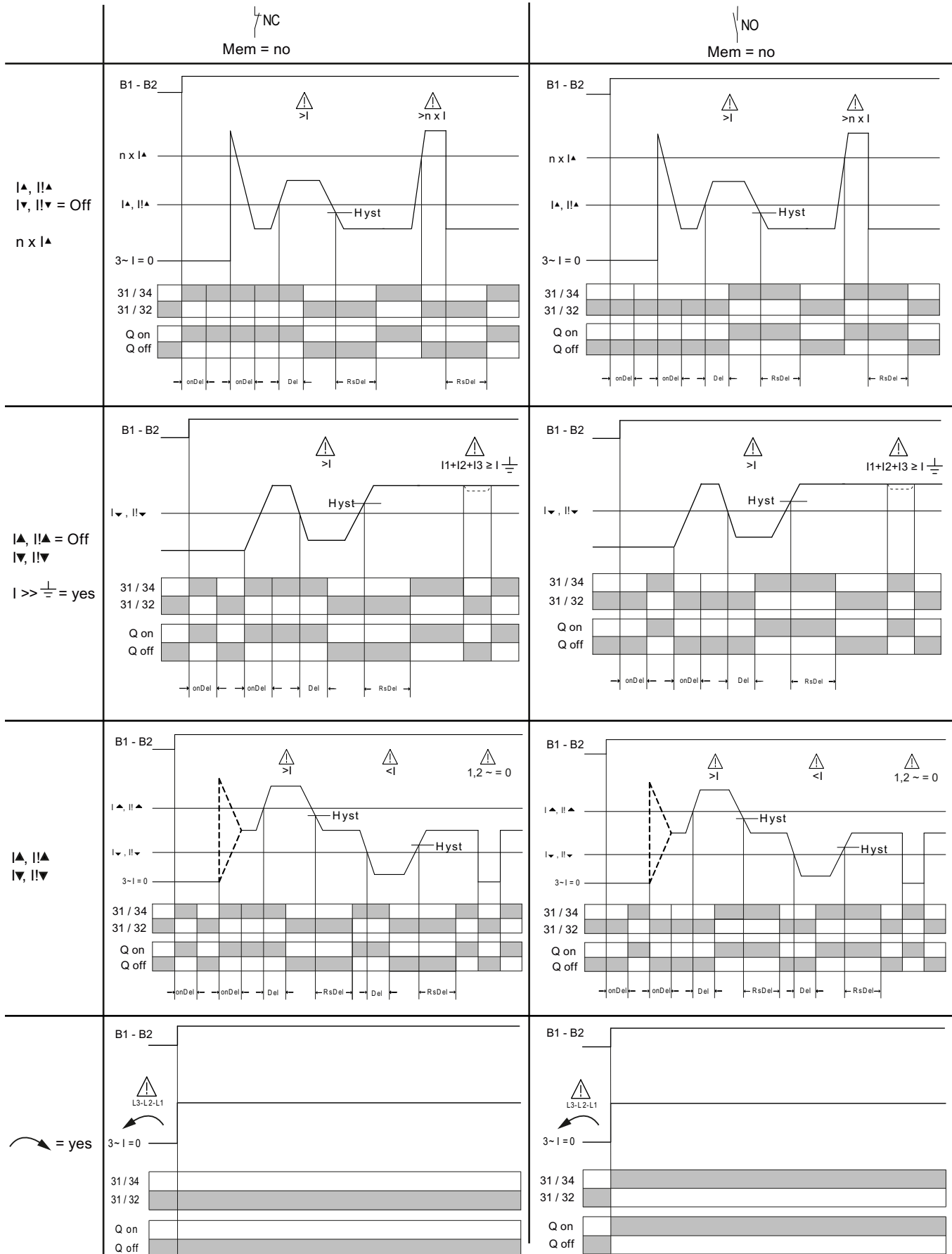



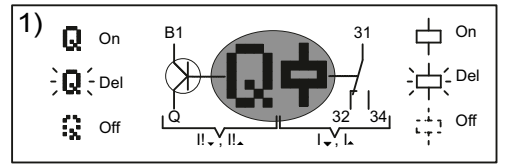
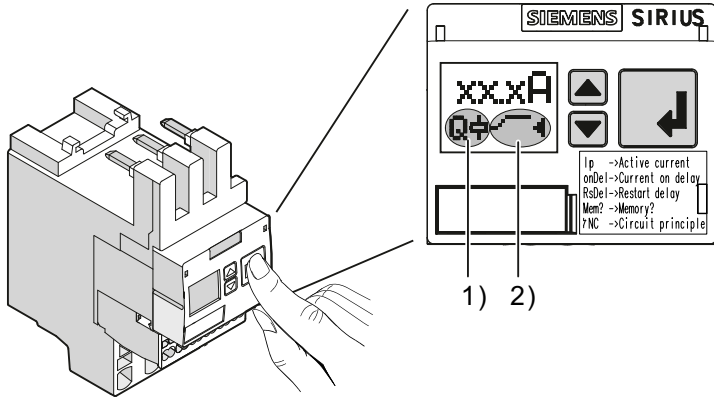





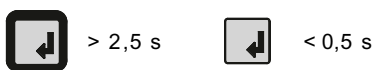
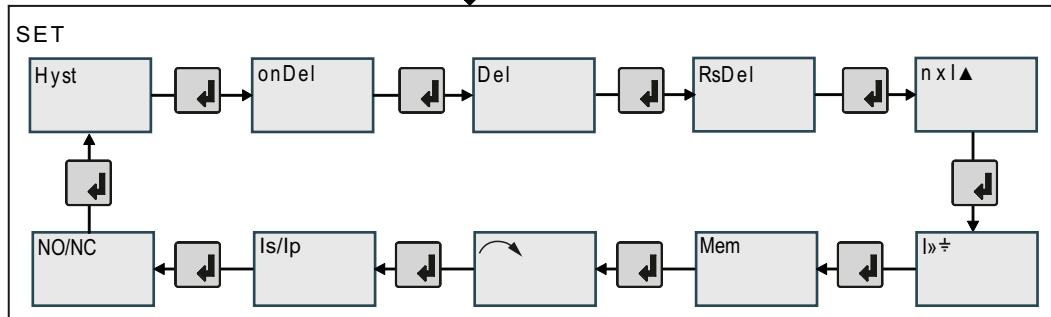
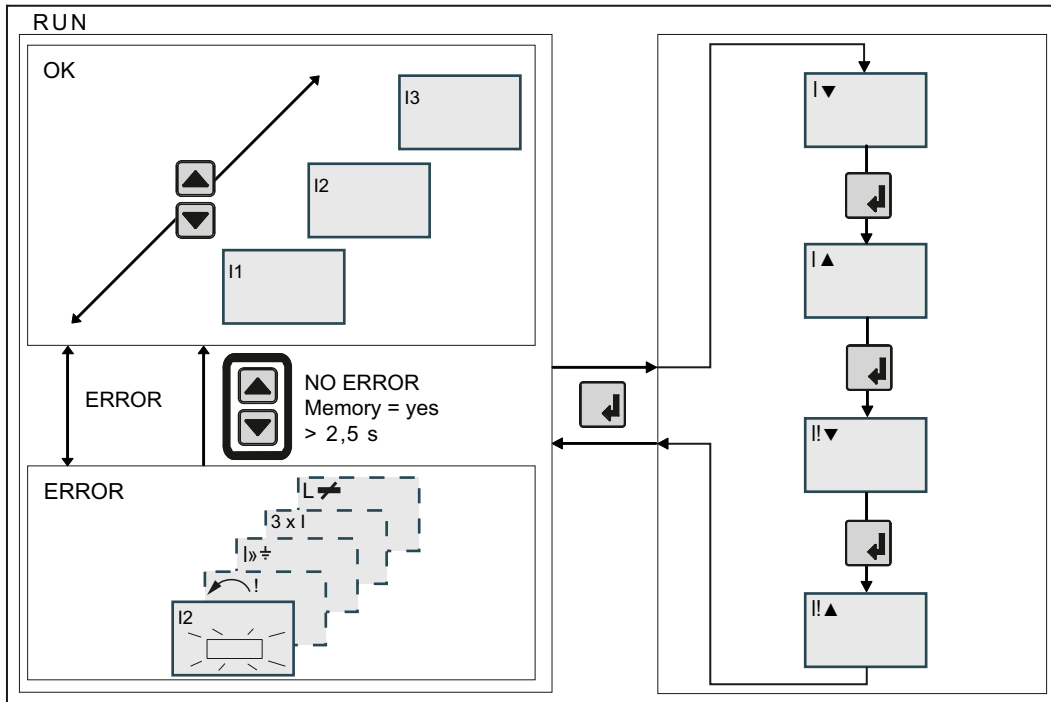























































DE	Menüführung 3RR224.	ES	Guía menú 3RR224.	TR	Menü yardımı 3RR224.
EN	Menu-based operation 3RR224.	IT	Guida menu 3RR224.	PY	Управление в режиме меню 3RR224.
FR	Guidage par menu 3RR224.	PT	Guia de menu 3RR224.	中文	菜单导航 3RR224.



2)

DE	Siehe Seite 12
EN	See page 12
FR	Voir page 12
ES	Véase página 12
IT	Vedi pagina 12
PT	Veja página 12
TR	Bkz. Sayfa 12
PY	мотри страницу 12
中文	见第 12 页



<p>DE</p> <p>Je nach Einstellung im Menü "Value" Anzeige oberer Schwellwert</p> <p> ▲ überschritten  ▼ nicht überschritten</p> <p>Anzeige unterer Schwellwert</p> <p> ▼ nicht unterschritten  ▲ unterschritten</p> <p>Anzeige Schwellwert</p> <p> ▲ überschritten  ▼ nicht über- unterschritten  ▼ unterschritten</p>	<p>ES</p> <p>Según el ajuste efectuado en "Value" Visualización Valor umbral superior</p> <p> ▲ rebasar lim.sup.  ▼ no rebasado</p> <p>Visualización Valor umbral inferior</p> <p> ▼ no rebasado  ▲ rebasar lim.inf.</p> <p>Visualización Valor umbral</p> <p> ▲ rebasar lim.sup.  ▼ no rebasado  ▼ rebasar lim.inf.</p>	<p>TR</p> <p>Ayara göre Menü "Value" Gösterge Üst eşik değeri</p> <p> ▲ Aşıldı  ▼ Aşılmadı</p> <p>Gösterge Alt eşik değeri</p> <p> ▼ Düşülmedi  ▲ Düşüldü</p> <p>Gösterge Eşik değeri</p> <p> ▲ Aşıldı  ▼ Aşılmadı /düşülmedi  ▼ Düşüldü</p>
<p>EN</p> <p>According to the settings in the "Value" menu Display upper threshold</p> <p> ▲ Exceeded  ▼ Not exceeded</p> <p>Display lower threshold</p> <p> ▼ Not below  ▲ Below</p> <p>Display Threshold</p> <p> ▲ Exceeded  ▼ not exceeded /- below  ▼ Below</p>	<p>IT</p> <p>A seconda dell'impostazione nel menu "Value" Display valore pulsante superiore</p> <p> ▲ superato  ▼ non superato</p> <p>Display valore pulsante inferiore</p> <p> ▼ non al di sotto  ▲ al di sotto</p> <p>Display valore pulsante</p> <p> ▲ superato  ▼ non superato /- al di sotto  ▼ al di sotto</p>	<p>РУ</p> <p>В зависимости от настройки в меню „Value“ („Величина“) Индикация Верхнее пороговое значение</p> <p> ▲ Превышает  ▼ Не превышает</p> <p>Индикация Нижнее пороговое значение</p> <p> ▼ Занижено  ▲ Занижено</p> <p>Индикация Пороговое значение</p> <p> ▲ Превышено  ▼ Не превышено и не занижено  ▼ Занижено</p>
<p>FR</p> <p>Selon le réglage dans le menu "Value" Affichage Valeur de seuil supérieur</p> <p> ▲ dépassé par le haut  ▼ non dépassé par le haut</p> <p>Affichage Valeur de seuil inférieur</p> <p> ▼ non dépassé par le bas  ▲ dépassé par le bas</p> <p>Affichage Valeur de seuil</p> <p> ▲ dépassé par le haut  ▼ non dépassé par le haut/-bas  ▼ dépassé par le bas</p>	<p>PT</p> <p>Dependendo do ajuste no menu "Value" Indicação valor limiar superior</p> <p> ▲ ultrapassado  ▼ não ultrapassado</p> <p>Indicação valor limiar inferior</p> <p> ▼ não caiu a um nível inferior  ▲ caiu a um nível inferior</p> <p>Indicação valor limiar</p> <p> ▲ ultrapassado  ▼ não ultrapassado / não caiu a um nível inferior  ▼ caiu a um nível inferior</p>	<p>中文</p> <p>按照在“数值”菜单中的设置 显示 上限</p> <p> ▲ 超出  ▼ 不超出</p> <p>显示 下限</p> <p> ▼ 不低于  ▲ 低于</p> <p>显示 极限域</p> <p> ▲ 超出  ▼ 不超出 /- 低于  ▼ 低于</p>

DE	Maßzeichnungen (Angaben in mm)	ES	Dibujos dimensionales (medidas en mm)	TR	Ölçü resimleri (Bilgiler mm olarak)
EN	Dimension drawings (all dimensions in mm)	IT	Disegni quotati (indicazioni in mm)	РУ	Размерные эскизы (Данные в мм)
FR	Encombrements (indications en mm)	PT	Desenhos cotados (dimensões em mm)	中文	尺寸图 (单位: mm)

3RR2241-1F.30

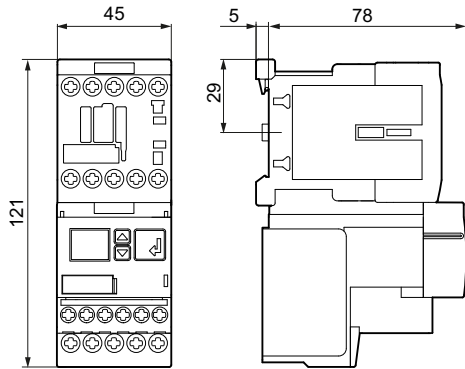

3RR2241-2F.30

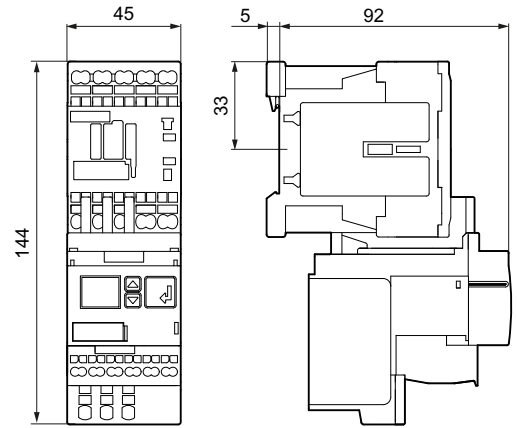

3RR2242-1F.30

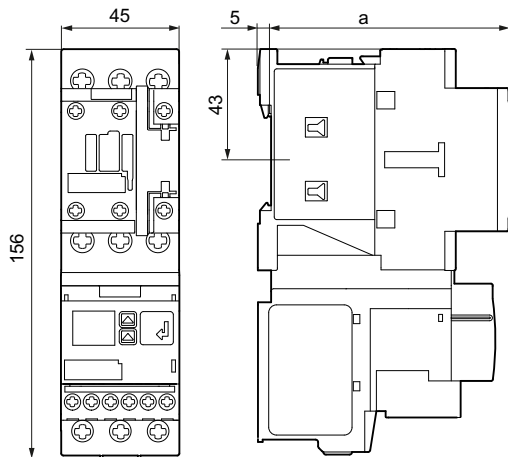

3RR2242-2F.30

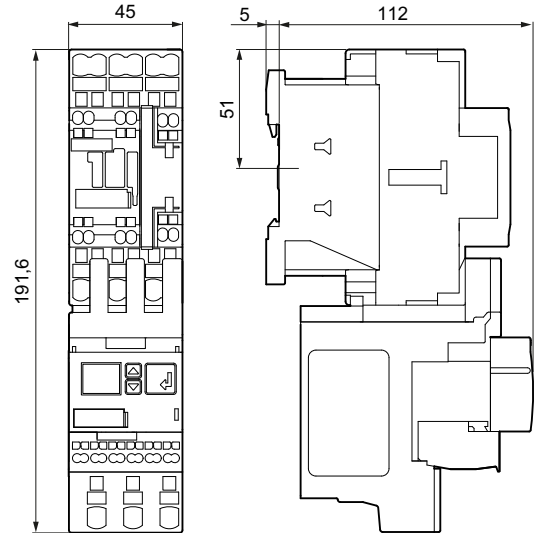

	AC	DC
a	92	102

3RR2241-1F.30
3RU2916-3AA01

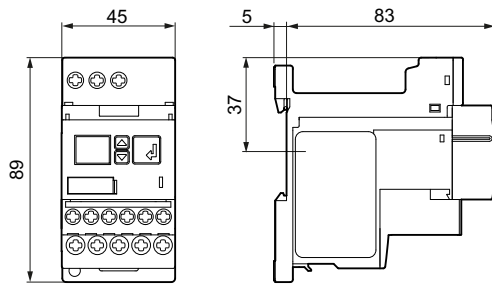

3RR2241-2F.30
3RU2916-3AC01

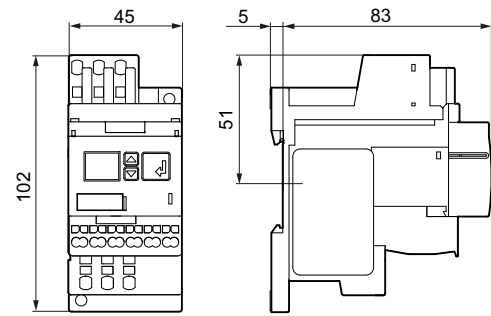

3RR2242-1F.30
3RU2926-3AA01

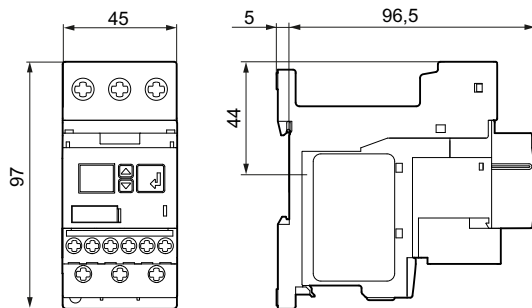

3RR2242-2F.30
3RU2926-3AC01

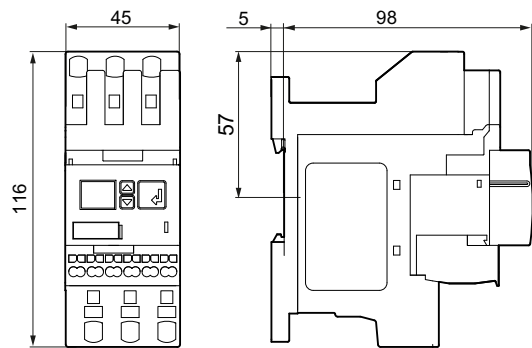

	DE	3ZX1012-0RA01-1AB1	www.siemens.de/industrial-controls/support
	EN	3ZX1012-0RA01-1AC1	www.siemens.com/industrial-controls/support