

SAMMELSCHIENENSYSTEM, ZUBEHOER
 SCHIENENMITTENABSTAND 40,60 MM
 ANSCHLUSSKLEMME 150...300 MM²
 SCHIENENPROFIL 20X5...30X10 MM UND FUER TT-
 PROFIL

Ausführung

Produkt-Markename	SENTRON
-------------------	---------

Zubehör

Zubehör	Anschlussklemme 5/10mm, 150-300
---------	---------------------------------

allgemeine Produktzulassung	Konformitätserklärung	Prüfbescheinigungen
-----------------------------	-----------------------	---------------------



[spezielle Prüfbescheinigungen](#)

Schiffbau	sonstiges
-----------	-----------



[sonstig](#)

Weitere Informationen

Information- and Downloadcenter (Kataloge, Broschüren,...)

<http://www.siemens.de/lowvoltage/kataloge>

Industry Mall (Online-Bestellsystem)

<https://eb.automation.siemens.com/mall/de/WW/Catalog/Product/8US19412AA02>

Service&Support (Handbücher, Betriebsanleitungen, Zertifikate, Kennlinien, FAQs,...)

<http://support.automation.siemens.com/WW/view/de/8US19412AA02/all>

Bilddatenbank (Produktfotos, 2D-Maßzeichnungen, 3D-Modelle, Geräteschaltpläne, ...)

http://www.automation.siemens.com/bilddb/cax_de.aspx?mlfb=8US19412AA02

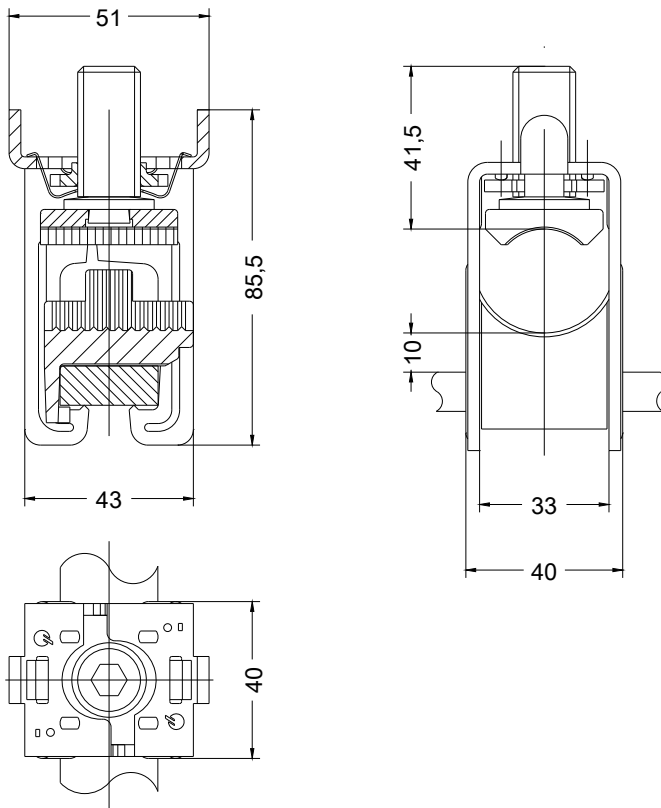

letzte Änderung:

11.03.2015