

W4S200-HK04-01

# AC axial compact fan

sickle-shaped blades (S series)



## ebm-papst Mulfingen GmbH & Co. KG

Bachmühle 2 · D-74673 Mulfingen

Phone +49 7938 81-0

Fax +49 7938 81-110

info1@de.ebmpapst.com

www.ebmpapst.com

Limited partnership · Headquarters Mulfingen

Amtsgericht (court of registration) Stuttgart · HRA 590344

General partner Elektrobau Mulfingen GmbH · Headquarters Mulfingen

Amtsgericht (court of registration) Stuttgart · HRB 590142

## Nominal data

Type	W4S200-HK04-01		
Motor	M4S068-BF		
Phase		1~	1~
Nominal voltage	VAC	230	230
Frequency	Hz	50	60
Method of obtaining data		fa	fa
Valid for approval/standard		CE	CE
Speed (rpm)	min <sup>-1</sup>	1370	1590
Power consumption	W	30	26
Current draw	A	0.21	0.18
Max. back pressure	Pa	50	50
Max. back pressure	inH <sub>2</sub> O	0.2	0.2
Min. ambient temperature	°C	-25	-25
Max. ambient temperature	°C	70	80

ml = Max. load · me = Max. efficiency · fa = Free air · cs = Customer specification · ce = Customer equipment  
Subject to change



### Technical description

<b>Weight</b>	2.0 kg
<b>Fan size</b>	200 mm
<b>Rotor surface</b>	Painted black
<b>Blade material</b>	Sheet steel, painted black
<b>Housing material</b>	Die-cast aluminum
<b>Number of blades</b>	7
<b>Airflow direction</b>	"V"
<b>Direction of rotation</b>	Counterclockwise, viewed toward rotor
<b>Degree of protection</b>	IP44; installation- and position-dependent
<b>Insulation class</b>	"B"
<b>Moisture (F) / Environmental (H) protection class</b>	H0 - dry environment
<b>Max. permitted ambient temp. for motor (transport/storage)</b>	+ 80 °C
<b>Min. permitted ambient temp. for motor (transport/storage)</b>	- 40 °C
<b>Installation position</b>	Any
<b>Condensation drainage holes</b>	None
<b>Mode</b>	S1
<b>Motor bearing</b>	Ball bearing
<b>Touch current according to IEC 60990 (measuring circuit Fig. 4, TN system)</b>	< 0.75 mA
<b>Motor protection</b>	Thermal overload protector (TOP) internally connected
<b>With cable</b>	Variable
<b>Protection class</b>	I (with customer connection of protective earth)
<b>Conformity with standards</b>	EN 60335-1; CE
<b>Approval</b>	UL 2111; CCC; EAC; VDE; CSA C22.2 No. 77

## Product drawing

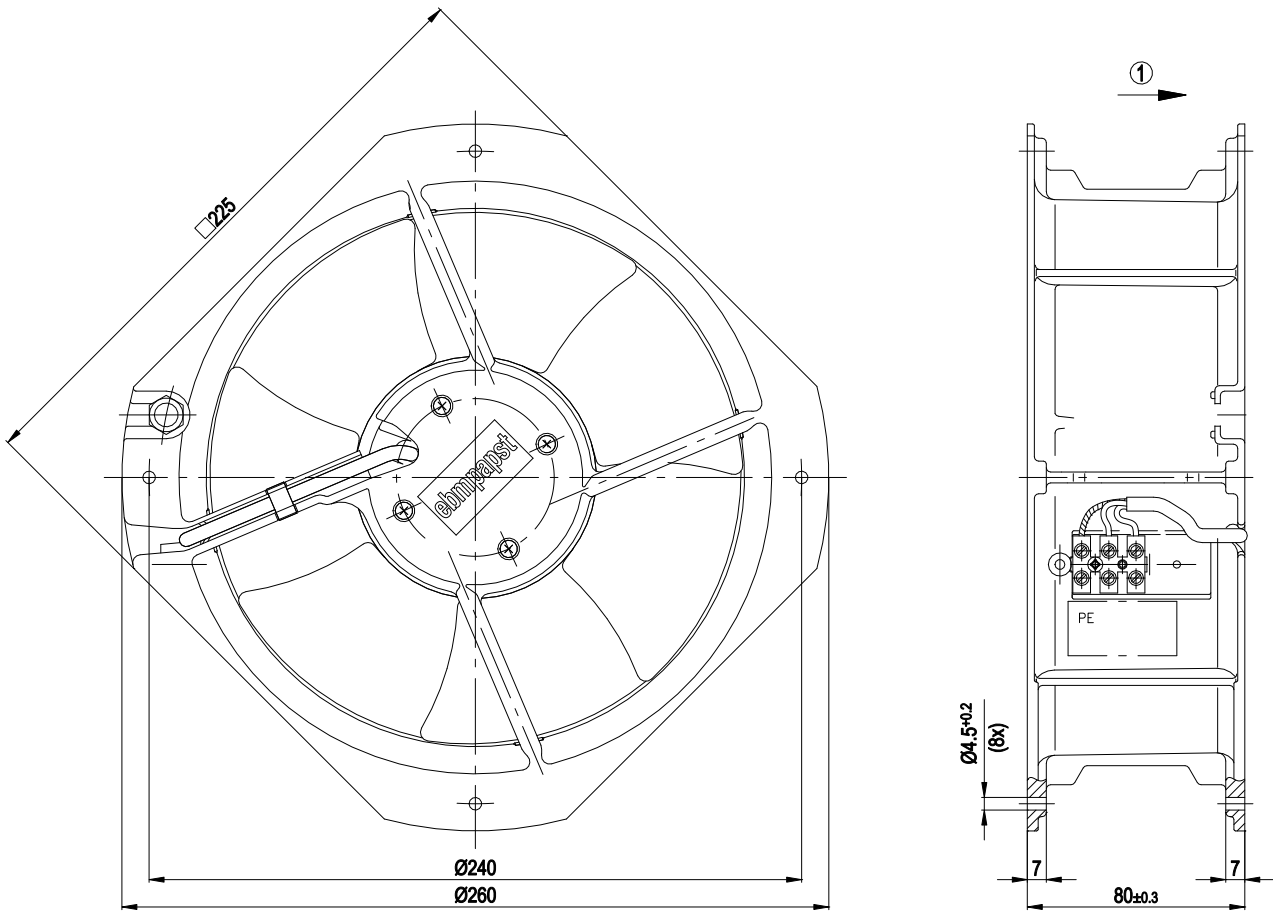

1 Direction of air flow "V"

## Connection diagram

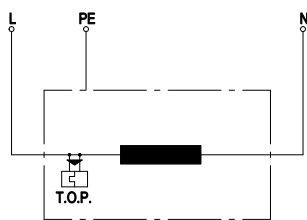

L	= blue
PE	= green/yellow
N	= brown
TOP	= thermal overload protector

## Curves: Air performance 50 Hz

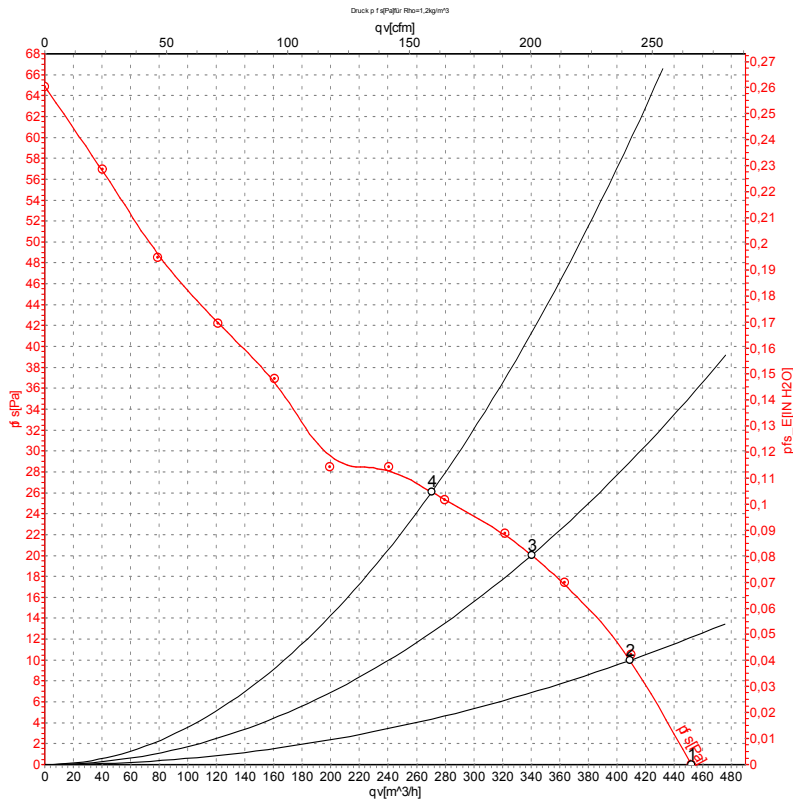

Measurement: LU-60315-1

Air performance measured according to ISO 5801 installation category A. For detailed information on the measurement setup, contact ebm-papst. Intake sound level: Sound power level according to ISO 13347 / sound pressure level measured at 1 m distance from fan axis. The values given are valid under the specified measuring conditions and may vary due to conditions of installation. For deviations from the standard configuration, the parameters have to be checked on the installed unit.

## Measured values

	U	f	n	P <sub>e</sub>	I	qv	p <sub>fs</sub>	qv	p <sub>fs</sub>
	V	Hz	min <sup>-1</sup>	W	A	m <sup>3</sup> /h	Pa	CFM	inH <sub>2</sub> O
1	230	50	1370	30	0.21	450	0	265	0.00
2	230	50	1365	29	0.21	410	10	240	0.04
3	230	50	1345	30	0.21	340	20	200	0.08
4	230	50	1330	31	0.22	270	26	160	0.10

U = Power supply · f = Frequency · n = Speed (rpm) · P<sub>e</sub> = Power consumption · I = Current draw · qv = Air flow · p<sub>fs</sub> = Pressure increase



## Curves: Air performance 60 Hz

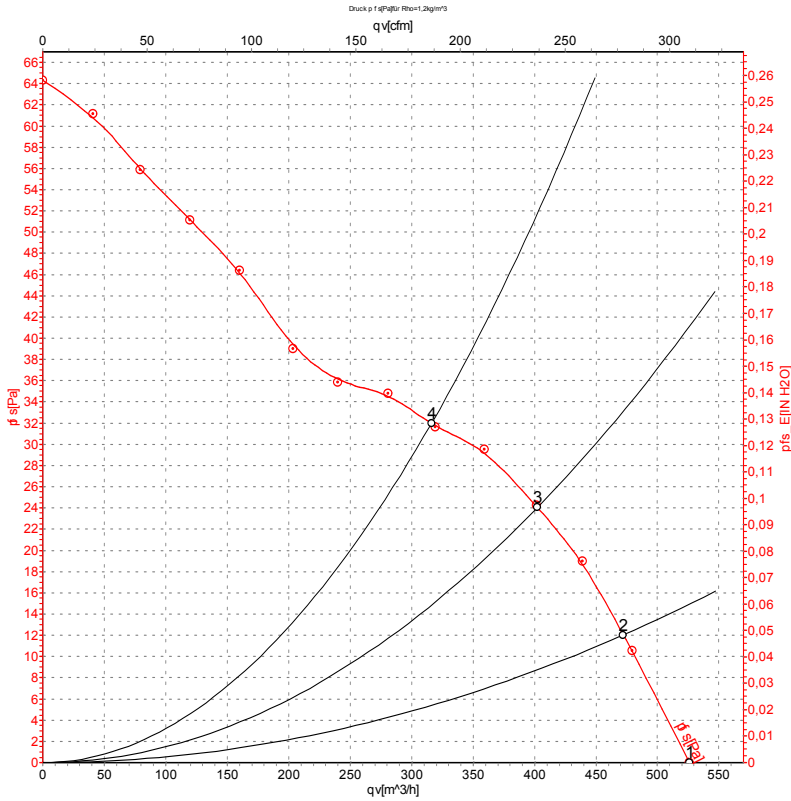

Measurement: LU-60316-1

Air performance measured according to ISO 5801 installation category A. For detailed information on the measurement setup, contact ebm-papst. Intake sound level: Sound power level according to ISO 13347 / sound pressure level measured at 1 m distance from fan axis. The values given are valid under the specified measuring conditions and may vary due to conditions of installation. For deviations from the standard configuration, the parameters have to be checked on the installed unit.

## Measured values

	U	f	n	P <sub>e</sub>	I	q <sub>v</sub>	p <sub>fs</sub>	q <sub>v</sub>	p <sub>fs</sub>
	V	Hz	min <sup>-1</sup>	W	A	m <sup>3</sup> /h	Pa	CFM	inH <sub>2</sub> O
1	230	60	1590	26	0.18	525	0	310	0.00
2	230	60	1560	27	0.18	470	12	280	0.05
3	230	60	1530	28	0.19	400	24	235	0.10
4	230	60	1495	29	0.19	315	32	185	0.13

U = Power supply · f = Frequency · n = Speed (rpm) · P<sub>e</sub> = Power consumption · I = Current draw · q<sub>v</sub> = Air flow · p<sub>fs</sub> = Pressure increase

