

# Visual Signals XENON

## BEACONS

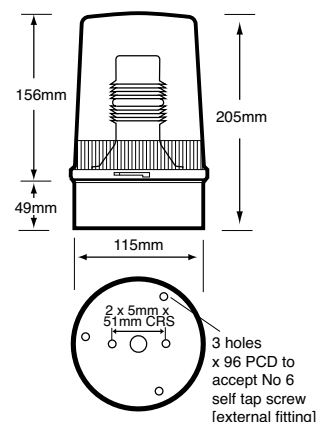

## Industrial Xenon Beacons > X201-200 Series

### Product overview

The X201/200 Series utilises a discharge capacitor and converter circuit to ignite xenon gas inside a tube, resulting in a brilliant flash of light. Xenon gas ignites virtually instantaneously so maximum brightness is obtained immediately. Xenons have an added advantage of low current consumption combined

with a reasonable life span. The X201/200 Series provides a 360-degree light output and has a Single Flash or Double Flash option. The Double Flash option extends the signal duration making it more noticeable to the human eye. Brightness is increased by the use of a Dioptic (Fresnel) lens which magnifies the light output. Xenon beacons are one of the most efficient, effective and brightest visual signals available.

### Features

- Continuously rated
- Suitable for use with conduit BESA box
- Suitable for surface or wall mounting
- Optional wall bracket & protective guard available – see accessory page
- Single or Double flash option
- Diode polarised [DP] options available for fire alarm systems
- 360° visibility
- IP65

### Material

- UV Stable Polycarbonate Lens
- UV Stable ABS Plastic Base

Code No:	Voltage:	Light Source:	Current:
X201-18●	12/24v Dc ---	Xenon 10J/7.5J	1.45/0.7 A
X201-19●●	12/24v Dc ---	Xenon 10J/7.5J	1.45/0.7 A
X200-88	24v Ac ~	Xenon 10J/7.5J	0.72 A
X200-21	115v Ac ~	Xenon 10J/7.5J	0.10 A
X200-22	230v Ac ~	Xenon 10J/7.5J	0.06 A

● Pre-set at 24v Dc ---

●● Diode polarised



**Kg** 0.72

50/60 **Hz**

°C -25+66

**IP** 65

**FPM** 60x90

**FIRE**

APPROVAL AND CONFORMITIES



ADD THE FOLLOWING LENS CODES TO THE PRODUCT CODE WHEN ORDERING

01 02 03 04 05

INDUSTRIAL