

# ECO.40S

## Kernboormachine

**EUROBOOR**

FOR PROFESSIONALS BY PROFESSIONALS

### Technische data

	Metrisch	Imperisch
Kernboren	Ø 12 - 40 mm	Ø 1/2" - 1 9/16"
Spiraalboren	Ø 1 - 16 mm	Ø 1/16" - 5/8"
Verzinken	Ø 10 - 45 mm	Ø 3/8" - 1 3/4"
<hr/>		
Lengte	264 mm	10 3/8"
Breedte	180 mm	7 1/16"
Hoogte	360 - 440 mm	14 3/16" - 17 5/16"
<hr/>		
Slag	145 mm	5 11/16"
Gewicht*	10,5 kg	23,1 lbs
Magneet (l x b x h)	160 x 80 x 42 mm	6 5/16" x 3 1/8" x 1 5/8"
Magnetische kracht	1.500 kg	3.305 lbs
Motor vermogen	1.150 W	10,5 A
Totaal vermogen	1.200 W	10,9 A
Toerental (onbelast)		600 tpm
Toerental (belast 1.150 W, 10,5 A)		380 tpm
Opname (Weldon)	19,05 mm	3/4"
Krachtvoorziening		110 - 120 V / 60 Hz 220 - 240 V / 50 - 60 Hz

\* Zonder stroomkabel en hendels

### Kenmerken



Olie bad  
versnellingsbak



Magneet  
LED-indicator  
(SensorTec)

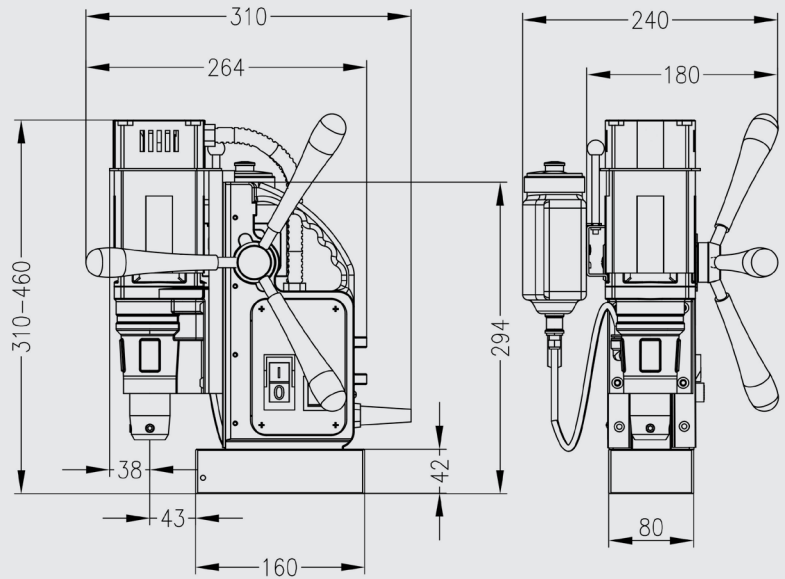

Euroboor stelt alles in het werk om te voldoen aan kwaliteits- en integriteitseisen. Daarom zijn wij als organisatie trots op de erkenning van enkele toonaangevende instanties wereldwijd:



[www.euroboor.com](http://www.euroboor.com)