

5-A multi-clamp, „two-in-one“ set

incl. 2x standard jaw and 2x screw-in jaw

ATORN®

Version

- The position of the fixed and movable jaws can be altered on the rail so that large and small parts are always central relative to the table
- System can be extended endlessly using the adapter set. (On request)
- When clamping with increased clamping width, clamping distance is only 30 mm less than rail length. Example rail length of 400 mm, 370 mm possible clamping distance.
- Positive-locking jaw interface
- Easy to clean. The entire system can be disassembled, cleaned and reassembled in a few minutes.
- 100 mm clamping range without adjustment

Advantage

- Extremely stiff for low vibration
- Two in one, system can be used as a 5-A and a multiple clamping system. This is unique. The base is an ATORN clamping rail from the 120 series.
- Tool-free spindle extension, click in or out and it's ready. Smart clamping solution at ideal value for money
- Simple and straightforward to handle, the system can be changed over very quickly.
- Interfering edges optimised in design

Delivery

Art. no.: 28759701 = 1 pc. Clamping rail; 1 pc. 5-axis design complete; 2 pcs. Standard jaw; 2 pcs. Screw-in jaw; 1 pc. Spindle extension, 1 pc. Hand crank; art. no.: 28759702 = 1 pc. Clamping rail; 1 pc. 5-axis design complete; 2 pcs. Standard jaw; 2 pcs. Screw-in jaw; 2 pcs. Spindle extension, 1 pc. Hand crank; art. no.: 28759703 = 1 pc. Clamping rail; 1 pc. 5-axis design complete; 2 pcs. Standard jaw; 2 pcs. Screw-in jaw; 3 pcs. Spindle extension, 1 pc. Hand crank; art. no.: 28759704 = 1 pc. Clamping rail; 1 pc. 5-axis design complete; 2 pcs. Standard jaw; 2 pcs. Screw-in jaw; 4 pcs. Spindle extension, 1 pc. Hand crank

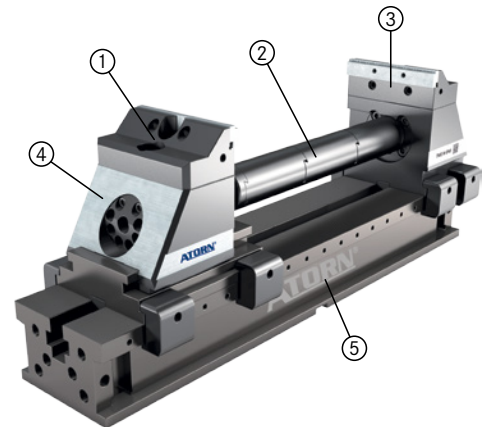

Art. no.	28759 701
Clamping rail length	300 mm
Clamping rail width	120 mm
Clamping rail height	80 mm
Min./max. clamping width	0-270 mm

EAN-Code

4050293628913