

# E30013

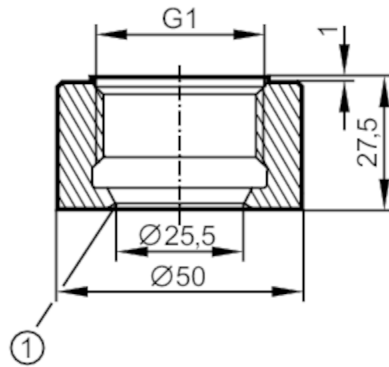

## Welding adapter for process sensors

WELDING ADAPT G1 V4A



1 sealing edge

CRN EC 1935/2004 EHEDG Tested FCM FDA

Application	
Pressure rating [bar]	150
Note on pressure rating	for the connection sensor - adapter
MAWP (for applications according to CRN) [bar]	150
Tests / approvals	
Pressure Equipment Directive	A possible classification to PED depends on the application and has to be carried out by the user / operator.
Safety instructions	The compatibility between medium and product material has to be checked in all applications.
Mechanical data	
Weight [g]	300
Materials	stainless steel (1.4404 / 316L)
Sensor connection	G 1
Process connection	welding adapter D50
Surface characteristics Ra/Rz of the wetted parts	0.4 / 4
Remarks	
Pack quantity	1 pcs.