





BUSBAR SYSTEM, ACCESSORY CENTER-TO-CENTER DISTANCE 40, 60 MM TERMINAL RAIL THICKNESS: 100MM+DOUBLE T PROFILE FOR COPPER RAILS AND LAMINATED COPPER STRIPS ON BUSBARS 2X40X10MM ALSO FOR OBLONG CONNECTIONS

Model

product brand name: SENTRON

General Product Approval	Declaration of Conformity	Test Certificates	Shipping Approval
 CSA  GOST  EAC	 EG-Konf.	Special Test Certificate	 GL

Shipping Approval

Shipping Approval	other
 PRS  RINA	other

Further information

- Information- and Downloadcenter (Catalogs, Brochures,...)
<http://www.siemens.com/lowvoltage/catalogs>
- Industry Mall (Online ordering system)
<https://eb.automation.siemens.com/mall/en/WW/Catalog/Product/8US19412BA00>
- Service&Support (Manuals, Certificates, Characteristics, FAQs,...)
<http://support.automation.siemens.com/WW/view/en/8US19412BA00/all>
- Image database (product images, 2D dimension drawings, 3D models, device circuit diagrams, ...)
http://www.automation.siemens.com/bilddb/cax_en.aspx?mlfb=8US19412BA00
- CAX-Online-Generator
<http://www.siemens.com/cax>

Tender specifications

<http://ausschreibungstexte.siemens.com/tiplv>

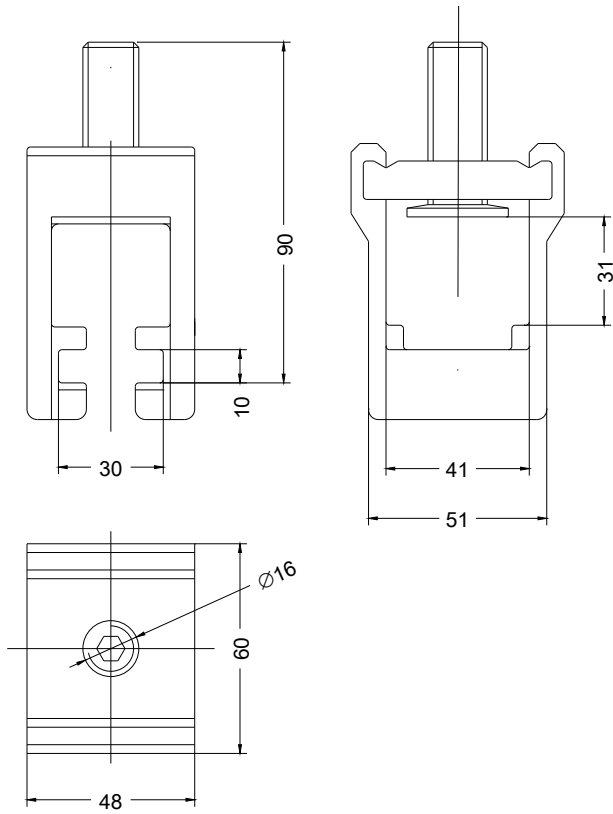

last modified:

11.03.2015